

# Operation Manual

Model Number : PM-0XXX-T

V3.1

---

**Copyright © 2006 DataVisor Marquees Inc.**

---

<b>Input Connections</b> .....	1
Input Specifications .....	1
Sensor Power Supply .....	1
Input Connectors Pinout .....	2
Connector Pin Location .....	3
Sample Connection Diagrams .....	3
<b>Using The IR Remote</b> .....	5
Key Usage Of IR Remote .....	6
The IR Menus Of The Marquee .....	7
Programming With The IR Remote .....	8
Entering Into Program Mode .....	8
Maneuvering Through Setup Menus .....	9
Resetting Process Values .....	10
Setting GOAL Count .....	11
Setting IP Address .....	12
Setting SubNET Mask .....	13
Setting Default Gateway .....	14
Setting Time .....	15
Setting Date .....	16
<b>Making The Ethernet Connection</b> .....	17
Quick Setup .....	18
Required Equipment .....	18
Steps To Connect The Marquee Via Ethernet .....	18
Detailed Ethernet Setup .....	20
Configuring the PC .....	20
Using IPCONFIG To Verify Ethernet Settings .....	24
Connecting The PC To The Marquee .....	26
Verifying Ethernet Communications .....	28
Connecting To the Marquee's WEB Server .....	31
<b>Marquee WEB Pages</b> .....	35
MONITOR PAGE .....	35
Access Configuration Pages .....	36
SETUP MENU .....	37
BACKUP/RESTORE CONFIGURATION .....	38
BREAK/DOWN TIMES CONFIGURATION .....	41
OEE/COUNT/RATE/TAKT TIMER/DOWNTIME .....	42
EVENT DRIVEN COLOR CHANGE .....	45
INPUT CONFIGURATION .....	46
JOB SETTINGS PAGE .....	50
MESSAGE DISPLAY AND DATA SOURCE .....	52
MONITOR PAGE CONFIGURATION .....	59
NETWORK SETTINGS .....	62
STATE TEXT AND OVERRIDE MESSAGES .....	65
TIME BASED RESET .....	68
TIME SYSTEM SETTINGS .....	69

WEB DATA CONFIGURATION .....	71
<b>Available Production Variables</b> .....	73
TOTAL COUNT .....	75
BAD COUNT .....	76
GOAL .....	77
GOAL - COUNT .....	77
% BAD .....	77
% COMPLETE .....	78
TARGET COUNTER .....	79
% OF TARGET COUNTER .....	80
HISTORICAL COUNT .....	80
DOWNTIME .....	81
RUNTIME .....	81
SETUP TIME .....	82
USER MODE TIME .....	82
HISTORICAL DOWNTIME .....	83
CURRENT CYCLE TIME .....	83
LAST CYCLE TIME .....	83
SHORTEST CYCLE TIME .....	83
LONGEST CYCLE TIME .....	83
AVERAGE CYCLE TIME .....	84
RATE VARIABLES (PER SECOND/MINUTE/HOUR) .....	85
Takt TIME Elapsed/ Takt TIME Remaining .....	86
QUALITY .....	87
MACHINE AVAILABILITY .....	87
MACHINE PERFORMANCE .....	87
OEE .....	87
MACHINE STATE .....	88
MODBUS/TCP reg. VARIABLES .....	88
TIME .....	89
DATE .....	89
<b>Web Data Configuration</b> .....	91
Configuring The WEB DATA Variables .....	91
Setting-up Excel For WEB DATA .....	93
<b>Modbus/TCP Server</b> .....	97
Modbus/TCP Client Setup .....	97
Modbus/TCP Memory Map Variables .....	98
Modbus/TCP Memory Map Configuration and Control .....	99
<b>Mounting Instructions</b> .....	101
Mounting Hardware Included .....	101
Installing Mount Attachment Bolts .....	102
Mounting Method Samples .....	103

# —Chapter 1—

## Input Connections

---

This chapter will discuss the multiple ways to connect devices that will be used by the Marquee for doing such operations as Count, Reset and Downtime Monitoring.

### Input Specifications

---

The model PM-0XX0-T is equipped with 6 inputs that are user configured for multiple different operations.

**Table 1—Input Specification**

Voltage	15-30 VDC
Type	NPN (requires sourcing device)
Minimum Pulse Width	10 Msec
Current Draw	<1 mA

### Sensor Power Supply

---

Along with the 4 inputs the Marquee also has a built in sensor power supply. This supply is intended to power sensor devices or provide power to push buttons or dry contact devices.

**Table 2—Sensor Supply Specifications**

Voltage	24 VDC
Current	1 Amp

## Input Connectors Pinout

Access to the inputs and the sensor power supply is accomplished by 2 eurofast quick disconnect connectors located on the bottom of the Marquee.

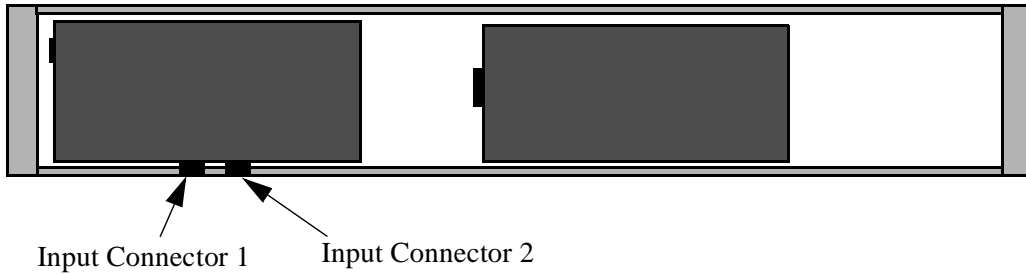

Figure 1— Marquee Connection Location

**Note:** The following pinout tables use a standard for eurofast cable colors please verify your cable color code prior to powering system. There are many manufactures of pre-made cable sets that will work with the Marquee. **Contact your sensor distributor for assistance in picking the right cable combination.**

Table 3—Input Connect #1 Pinout

Pin Number	Description	Cable Color Code
1	+24 Vdc (sensor Power Supply Output)	Brown
2	Input #2	White
3	Common (24 Vdc GND)	Blue
4	Input #1	Black
5	Input #3	Grey

Table 4—Input Connector #2 Pinout

Pin Number	Description	Cable Color Code
1	+24 Vdc (sensor Power Supply Output)	Brown
2	Input #5	White
3	Common (24 Vdc GND)	Blue
4	Input #4	Black
5	Input #6	Grey

## Connector Pin Location

---

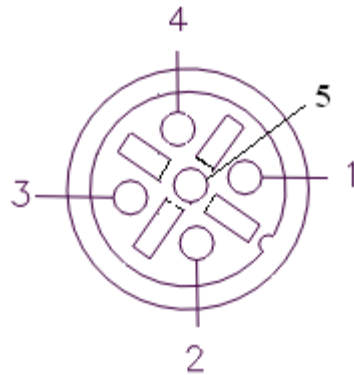

Figure 2—Connector Pin Locations

## Sample Connection Diagrams

---

### Dry Contact or Push Button Actuator

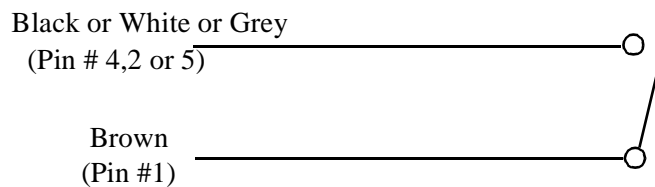

Figure 3—Dry Contact or Push Button wiring

### PLC Type Output

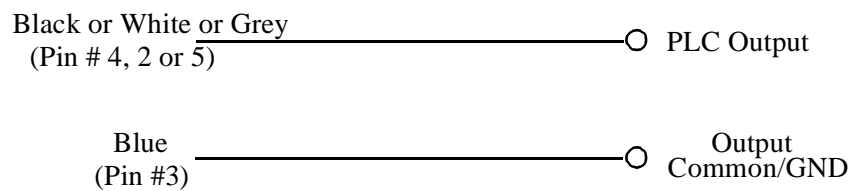

Figure 4—PLC Type Output

## Input Connections

**WARNING**—When connecting to a device that uses an existing 24 Vdc power source do not connect the Brown wire (24Vdc sensor output)

### Sensor Connection

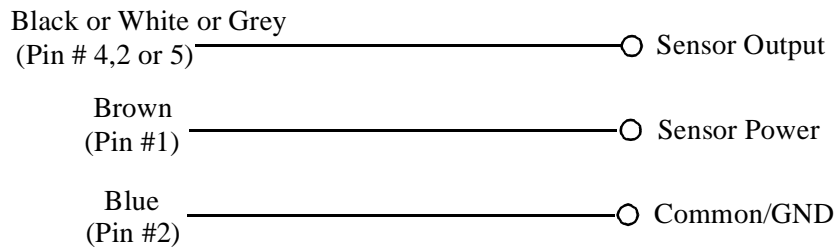

Figure 5—Sensor Connection

**Note:** A device known as a splitter can be purchased from several manufactures that breaks out the input connector so as the user has easy access to both inputs. **Contact your sensor distributor for assistance in picking the right cable combination.**

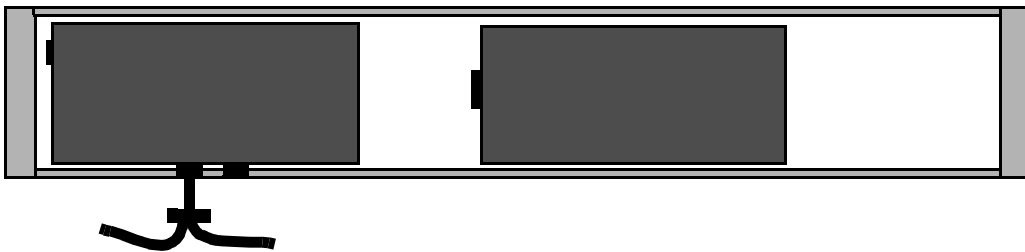

Figure 6—Splitter connection

## —Chapter 2—

### Using The IR Remote

---

This chapter will discuss the use to the IR remote. The remote is used to initially set the Network Parameters, Time and Date. It can also be used during operation to allow for resetting of process variables.

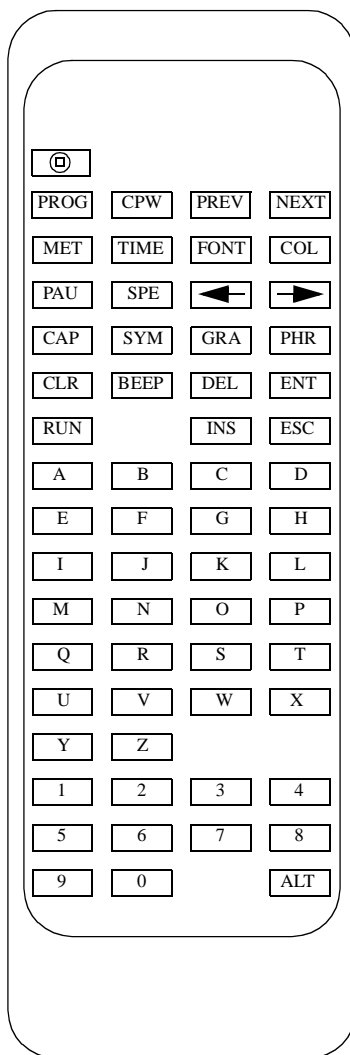

## Key Usage Of IR Remote

---

There are many keys that are not currently used for the operation of the Marquee display. The following lists the keys that have operation capability with the marquee.

<b>KEY</b>	<b>USAGE</b>
PROG	Enter Program Mode
PREV	Go To Previous Program Screen
NEXT	Go To Next Program Screen
←	Move Cursor To Left
→	Move Cursor To Right
RUN	Return to Operating Mode
Y	Used For Conformation Of Change
N	Used for Rejection Of Change
0-9	Numeric Keys For Data Entry

**Table 1—IR Remote Key Usage**

## The IR Menus Of The Marquee

---

The following are the menus that can be accessed via the IR remote. These menus allow the user to configure the basic settings of the Marquee display.

Menu	Usage
<div style="border: 1px solid black; padding: 5px; text-align: center;"> <b>RESET COUNTS?</b>            PRESS Y FOR YES         </div>	This menu item allows the user to reset the process variables via the IR remote.
<div style="border: 1px solid black; padding: 5px; text-align: center;"> <b>SET GOAL</b>            000000         </div>	Allows the user to set the GOAL count.
<div style="border: 1px solid black; padding: 5px; text-align: center;"> <b>IP ADDRESS</b>            192.168.1.200         </div>	Allows the user to set the Ethernet IP address for the built in ethernet port of the Marquee.
<div style="border: 1px solid black; padding: 5px; text-align: center;"> <b>NET MASK</b>            255.255.255.000         </div>	Allows the user to set the Ethernet SUB NET MASK for the built in Ethernet port of the Marquee.
<div style="border: 1px solid black; padding: 5px; text-align: center;"> <b>SET GATEWAY</b>            000.000.000.000         </div>	Allows the user to set the Ethernet DEFAULT GATEWAY for the built in Ethernet port of the Marquee.
<div style="border: 1px solid black; padding: 5px; text-align: center;"> <b>SET TIME</b>            02:47:37         </div>	Allows the user to set the TIME for the built in real time clock of the Marquee.
<div style="border: 1px solid black; padding: 5px; text-align: center;"> <b>SET DATE</b>            06/10/06         </div>	Allows the user to set the DATE for the built in real time clock of the Marquee.

**Table 2—Marquee Configuration Menus**

## Programming With The IR Remote

---

The following section will describe the steps that are taking in order to enter program mode and accessing the Marquee setup menus. In this section the user will be instructed on how to accomplish the following tasks.

- Reset Process variables
- Set the Goal count
- Set the Ethernet parameters of the Marquee
- Set the Time and Date on the Marquee display

## Entering Into Program Mode

---

In order to access the setup menus the user must put the Marquee into program mode. This is as simple as pressing the PROG key on the IR remote.

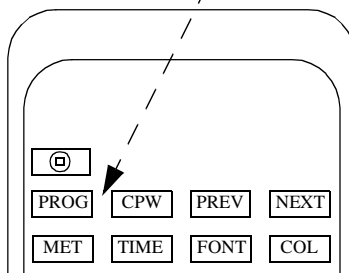

The follow message will be displayed on the Marquee.

RESET COUNTS? PRESS Y FOR YES
----------------------------------

**Note:** The user should be within 20 Ft of the Marquee in order for IR operations!

## Maneuvering Through Setup Menus

Once in program mode, the user uses the PREV and NEXT keys to scroll through the setup menus.

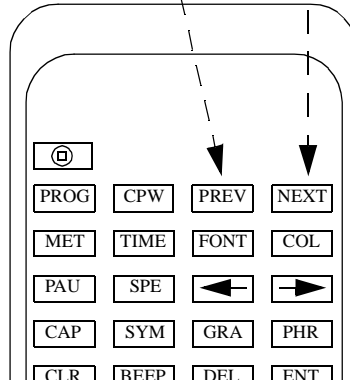

By using these keys the user can select the menu item that is desired and take appropriate action. The NEXT key takes the user to the next menu and the PREV key goes back to the previous menu. If the user is on the last menu and presses the NEXT key the first menu item will be displayed. If the user is on the first menu item and presses the PREV key the last menu item will be displayed.

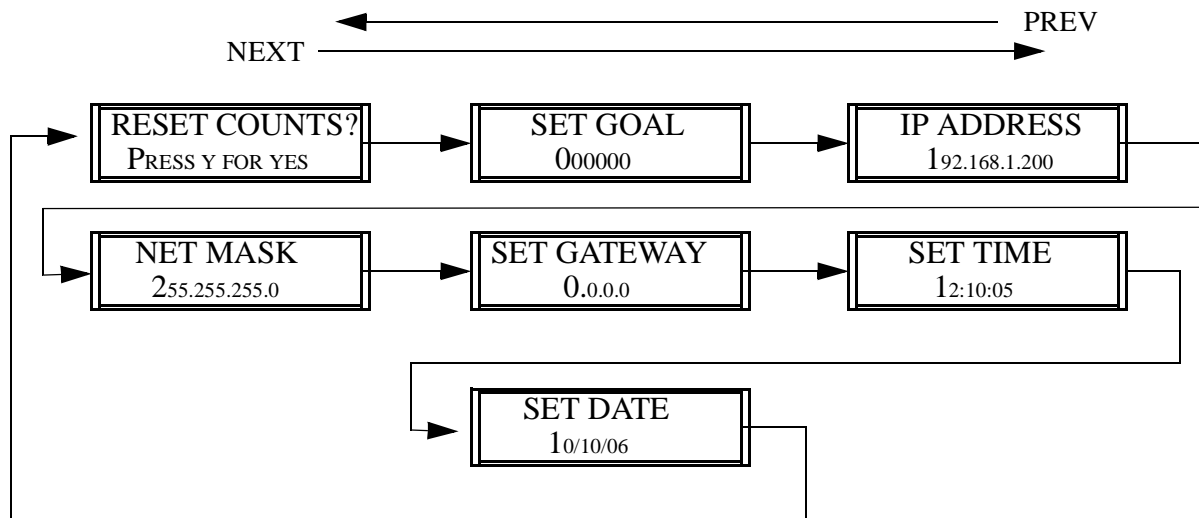

## Resetting Process Values

The user may choose to reset the process value (counts) via the IR remote. To accomplish this follow the following steps.

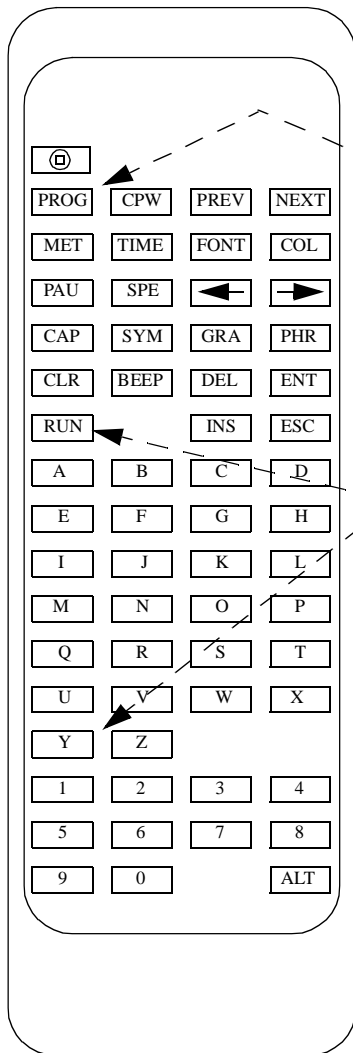

1. Press the PROG key to put Marquee into program mode.

2. The Following message will appear on the Marquee.

RESET COUNTS?  
PRESS Y FOR YES

3. Press the Y key on the remote to clear the counts.

4. The counts will be reset to 0 and the Marquee will return to operating mode.

## Setting GOAL Count

The user may choose to set the GOAL count via the IR remote. To accomplish this follow the following steps.

1. Press the PROG key to put Marquee into program mode.
2. The Following message will appear on the Marquee.
 

RESET COUNTS?  
 PRESS Y FOR YES
3. Press the NEXT key on the remote to go to the next menu item. The follow will be displayed on the Marquee.
 

SET GOAL  
 000000
4. The user should notice that the first digit within the GOAL set point is larger than the reset. This indicates the cursor position.
5. The cursor position can be moved by pressing the → or the ← key of the remote. As you move the cursor the enlarged value will move across the Marquee to indicate current cursor position.
 

Example: 123456    Press →  
           123456    Press ←  
           123456
6. By pressing any of the numeric keys will change the value of the current position to that value and move the cursor position to the right.
7. Once the proper value is displayed press the RUN key to return to operating mode.

## Setting IP Address

The user can set the Ethernet IP address of the built in Ethernet port via the IR remote. Follow these steps to accomplish this task.

1. Press the PROG key to put Marquee into program mode.
2. The Following message will appear on the Marquee.
 

RESET COUNTS?  
PRESS Y FOR YES
3. Press the NEXT key twice on the remote to go to the SET IP menu item. The following will be displayed.
 

IP ADDRESS  
192.168.1.200
4. The user should notice that the first digit within the IP address is larger than the reset. This indicates the cursor position.
5. The cursor position can be moved by pressing the → or the ← key of the remote. As you move the cursor the enlarged value will move across the Marquee to indicate current cursor position.
 

Example: 192.168.1.200 Press →  
           192.168.1.200 Press ←  
           192.168.1.200
6. By pressing any of the numeric keys will change the value of the current position to that value and move the cursor position to the right.
7. Once the proper IP address is displayed press the RUN key. The confirmation message will be displayed.
 

ACCEPT NEW IP  
PRESS Y FOR YES
8. At this point pressing the Y key will change the Marquees IP address and return the Marquee to operating mode.  
If the N key is pressed then the IP address will not be changed and the Marquee will return to operating mode.

## Setting SubNET Mask

The user can set the Ethernet SubNet Mask of the built in Ethernet port via the IR remote. Follow these steps to accomplish this task.

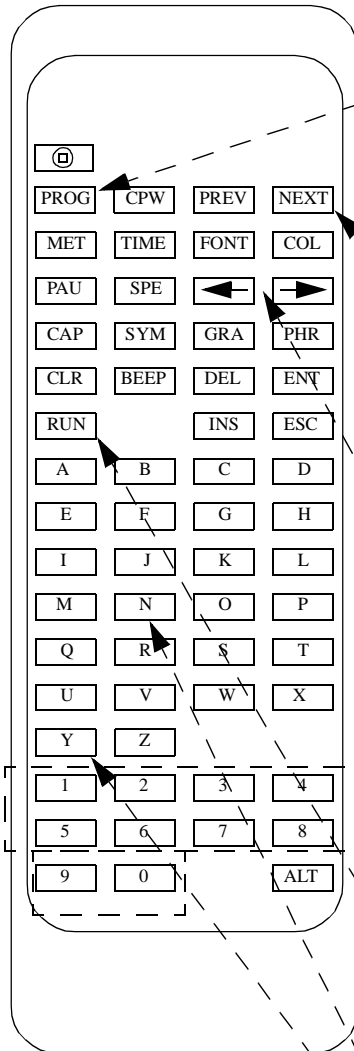

1. Press the PROG key to put Marquee into program mode.

2. The Following message will appear on the Marquee.

```

RESET COUNTS?
PRESS Y FOR YES
  
```

3. Press the NEXT key three times on the remote to go to the NET MASK menu item. The follow will be displayed.

```

NET MASK
  
```

```

255.255.255.0
  
```

4. The user should notice that the first digit within the mask is larger than the reset. This indicates the cursor position.

5. The cursor position can be moved by pressing the  $\rightarrow$  or the  $\leftarrow$  key of the remote. As you move the cursor the enlarged value will move across the Marquee to indicate current cursor position.

```

Example: 255.255.255.0 Press  $\rightarrow$ 
          255.255.255.0 Press  $\leftarrow$ 
          255.255.255.0
  
```

6. By pressing any of the numeric keys will change the value of the current position to that value and move the cursor position to the right.

7. Once the proper SubNet Mask is displayed press the RUN key. The confirmation message will be displayed.

```

ACCEPT NEW IP
PRESS Y FOR YES
  
```

8. At this point pressing the Y key will change the Marquees Subnet Mask and return the Marquee to operating mode.

If the N key is pressed then the Subnet Mask will not be changed and the Marquee will return to operating mode.

## Setting Default Gateway

The user can set the Ethernet Default Gateway of the built in Ethernet port via the IR remote. Follow these steps to accomplish this task.

1. Press the PROG key to put Marquee into program mode.
2. The Following message will appear on the Marquee.
 

RESET COUNTS?  
 PRESS Y FOR YES
3. Press the NEXT key four times on the remote to go to the GATEWAY menu item. The follow will be displayed.
 

SET GATEWAY  
 → 0.0.0
4. The user should notice that the first digit within the gateway is larger than the reset. This indicates the cursor position.
5. The cursor position can be moved by pressing the → or the ← key of the remote. As you move the cursor the enlarged value will move across the Marquee to indicate current cursor position.
 

Example: 255.255.255.0 Press →  
           255.255.255.0 Press ←  
           255.255.255.0
6. By pressing any of the numeric keys will change the value of the current position to that value and move the cursor position to the right.
7. Once the proper GATEWAY is displayed press the RUN key. The confirmation message will be displayed.
 

ACCEPT NEW IP  
 PRESS Y FOR YES
8. At this point pressing the Y key will change the Marquees Gateway and return the Marquee to operating mode. If the N key is pressed then the Gateway will not be changed and the Marquee will return to operating mode.

## Setting Time

The user can set the time of the built in real time clock via the IR remote. Follow these steps to accomplish this task.

1. Press the PROG key to put Marquee into program mode.
2. The Following message will appear on the Marquee.
 

RESET COUNTS?  
 PRESS Y FOR YES
3. Press the NEXT key five times on the remote to go to the SET TIME menu item. The follow will be displayed.
 

SET TIME  
 12:10:05
4. The user should notice that the first digit within the time is larger than the reset. This indicates the cursor position.
5. The cursor position can be moved by pressing the  $\rightarrow$  or the  $\leftarrow$  key of the remote. As you move the cursor the enlarged value will move across the Marquee to indicate current cursor position.
 

Example: 12:10:05    Press  $\rightarrow$   
           12:10:05    Press  $\leftarrow$   
           12:10:05
6. By pressing any of the numeric keys will change the value of the current position to that value and move the cursor position to the right.
7. Once the proper Time is displayed press the RUN key which sets the new time and puts the Marquee into operating mode.

## Setting Date

The user can set the date of the built in real time clock via the IR remote. Follow these steps to accomplish this task.

1. Press the PROG key to put Marquee into program mode.
2. The Following message will appear on the Marquee.
 

RESET COUNTS?  
 PRESS Y FOR YES
3. Press the NEXT key six times on the remote to go to the SET TIME menu item. The follow will be displayed.
 

SET DATE  
 10/10/06
4. The user should notice that the first digit within the date is larger than the reset. This indicates the cursor position.
5. The cursor position can be moved by pressing the → or the ← key of the remote. As you move the cursor the enlarged value will move across the Marquee to indicate current cursor position.
 

Example: 10/10/06    Press →  
           10/10/06    Press ←  
           10/10/06
6. By pressing any of the numeric keys will change the value of the current position to that value and move the cursor position to the right.
7. Once the proper Time is displayed press the RUN key which sets the new date and puts the Marquee into operating mode.

## Making The Ethernet Connection

---

This chapter describes the steps that are taken in order to connect the Marquee to an ethernet network or configuration PC to allow the configuration of the Marquee.

In most cases, the first step in configuring the Marquee is physically connecting the Marquee to what is known as a configuration PC. A configuration PC can be a laptop or desk-top PC that is equipped with an ethernet port and has WEB browser software installed. There are many different WEB browsers available on the market today. Please refer to the documentation for WEB browser that is being used if it is not clear what is needed to be accomplished.

The Marquee can be connected directly to a PC's ethernet port or connected to the facility network. It is recommended that the first time a user connects directly to the Marquee and does not connect to the facility network. By connecting directly, the user has more control over the ethernet network settings and the need to consult with the IT department or network administrator of the facility.

**Note:** Prior to connecting to the facility network, it is highly recommended to consult the facility IT department or the network administrator of the facility.

## Quick Setup

---

This section is designed for the user who is familiar with connecting devices via ethernet. This section assumes a direct connection between the ethernet port of a PC and the Ethernet port of the Marquee.

If the user is not familiar with connecting ethernet devices or configuring ethernet Parameters of the PC it is highly recommended to go to the section *Detailed Ethernet Setup* section.

## Required Equipment

---

- DataVisor Marquee
  - PC with Ethernet port and a Web browser installed
- Note:** The user must have administrator rights on the PC
- An Ethernet cross cable or a switch with an Ethernet patch cable.

## Steps To Connect The Marquee Via Ethernet

---

These steps use the factory default ethernet parameters that are set in the Marquee.

- IP Address 192.168.1.200
- Subnet Mask 255.255.255.0

1. Connect a ethernet cross-over cable between the PC and the Marquee

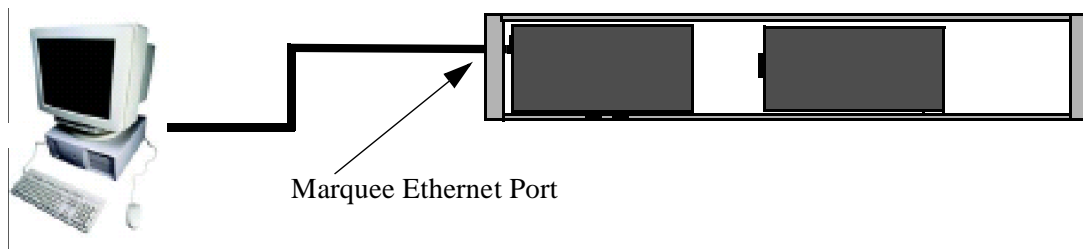

2. Apply power to the Marquee

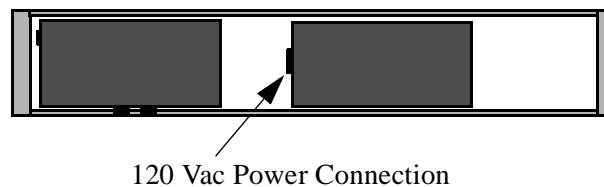

3. Power the PC
4. Configure the PC's ethernet port.
  - IP address 192.168.1.100
  - SubNet Mask 255.255.255.

**Note:** Refer to the section *Set the PC for Fixed IP Address* for detailed instructions.

4. Start the WEB browser application and enter the IP address of the Marquee in the address field.  
In the address bar type **http://192.168.1.200** then press the ENTER key

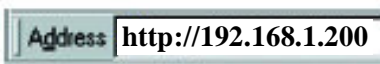

**Note:** On many browsers the **http://** is automatically added to the address so the user does not need to type it in.

6. At this point the MONITOR page of the Marquee should be displayed in Internet Explorer

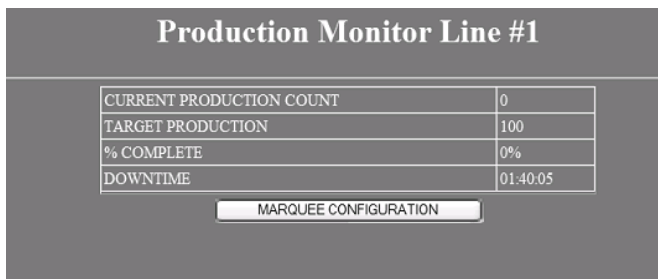
A screenshot of a web page titled 'Production Monitor Line #1'. It contains a table with production statistics and a button for configuration.

Production Monitor Line #1	
CURRENT PRODUCTION COUNT	0
TARGET PRODUCTION	100
% COMPLETE	0%
DOWNTIME	01:40:05

7. The user may now access the configuration WEB pages of the Marquee.

**Note:** Please refer to the section *Marquee Configuration Pages* for details on the configuration pages.

If the user has problems accessing the Marquee's WEB pages, please follow the detailed steps in the following section.

## Detailed Ethernet Setup

---

This section describes in detail the steps to establish an ethernet connection to the Marquee in order to configure it's operation. This section assumes the user will be using the default ethernet settings of the Marquee. If the user changes the default ethernet settings, such as the IP address, the user must use the new settings in place of the defaults when referenced in this section.

- Default IP address of Marquee 192.168.1.200
- Default SubNet Mask of Marquee 255.255.255.0
- Default Gateway of Marquee 0.0.0.0

This section is for connecting the Marquee directly to the PC. If the user wishes to connect the Marquee to the facility network, it is highly advised that the network administrator or IT department is involved. This is suggested so as the Ethernet network parameters of the Marquee can be configured to match the facility network parameters.

## Configuring the PC

---

The first step in making an Ethernet connection to the Marquee is to configure the PC so as the Ethernet port of the PC can communicate to the Marquee. After the PC has been powered up follow these steps to verify the configuration of the PC.

**Note:** Prior to making changes to the ethernet configuration of the PC the existing configuration should be documented. The user may be required to revert back to the existing configuration in order to connect to the facility network.

### Set the PC for a Fixed IP Address WINDOWS XP

Many facility networks in use today use what is known as DHCP to allow a server on the network to assign ethernet parameters to the PCs that are connected to the network. When connecting directly from the PC to another ethernet device such as the Marquee, the user must assign the Ethernet parameters of the PC manually.

#### Step 1

On the PC, click on START followed by CONTROL PANEL.

**Note:** Depending on the operation system of the PC the user may need to select SETTINGS in order to access the CONTROL PANEL.

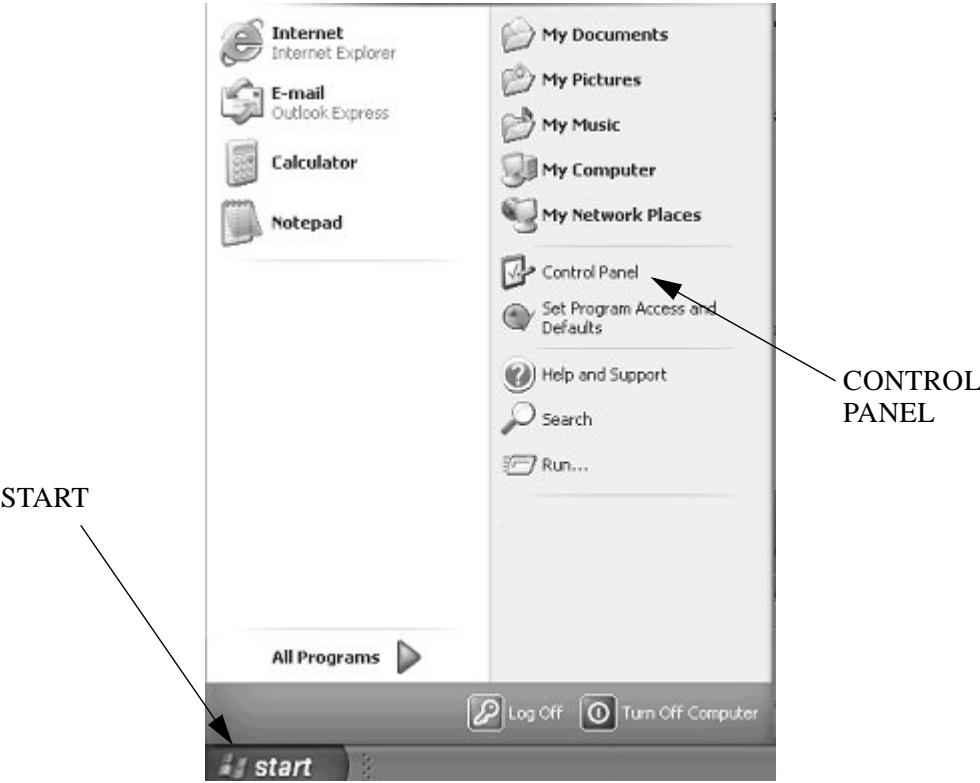

#### Step 2

In Control Panel double click on NETWORK CONNECTIONS.



## Making The Ethernet Connection

Detailed Ethernet Setup

### Step 3

Under NETWORK CONNECTIONS find the Icon that says LOCAL AREA NETWORK. Then double click on this Icon. This allows the user to configuration the PC's ethernet port.



### Step 4

One of two screens will be displayed. If the screen 1 is displayed, click the PROPERTIES button and screen 2 will be displayed.

SCREEN TYPE 1

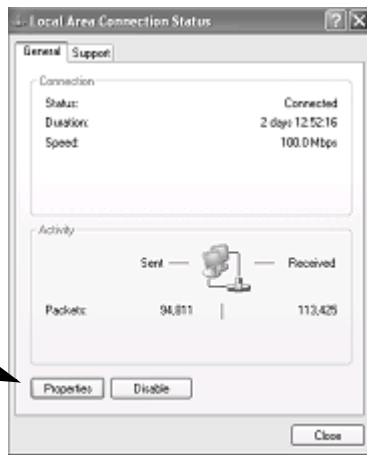

Properties Button

SCREEN TYPE 2



### STEP 5

Select selection INTERNET PROTOCOL (TCP/IP) in the THIS CONNECTION USES THE FOLLOWING ITEMS box. Then click the PROPERTIES button.

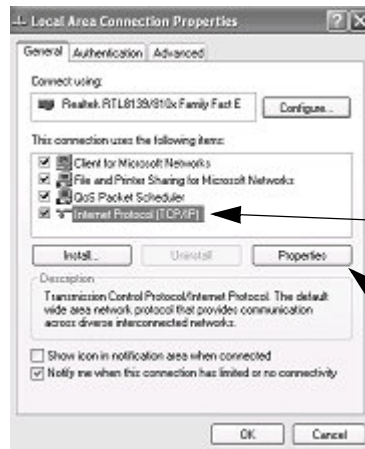

SELECT THIS ENTRY

PROPERTIES BUTTON

**STEP 6**

The properties for the TCP/IP communications is displayed. If the window looks like the screen below then the PC is set for connecting to as DHCP server. This means that the PC's ethernet parameters are generated by a DHCP server on the facility network. In order to make a direct connection to the Marquee the user must manually enter the Ethernet parameters. To accomplish this first select the item USE THE FOLLOWING IP ADDRESS. At this point the user will enter the IP address 192.168.1.100 and the SubNet Mask of 255.255.255.0.

After entry is completed click the OK button on each of the Network windows. This will cause the PC to accept the changes and reconfigure the local Ethernet port.

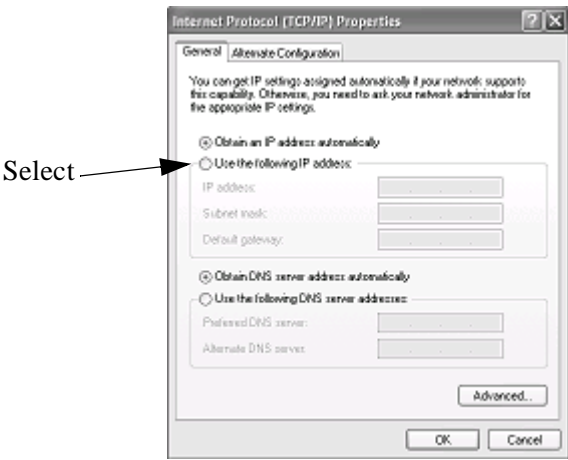

Enter IP address and Subnet Mask



Click OK

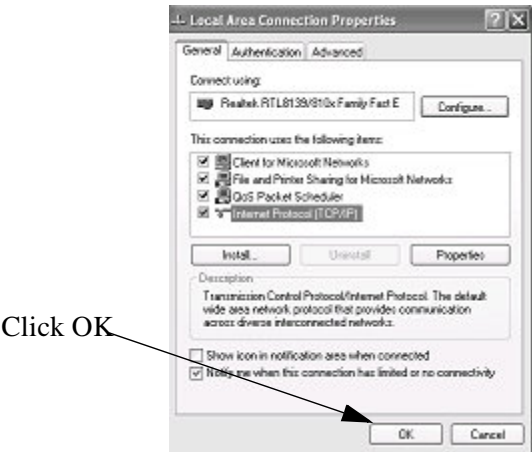

Click Close

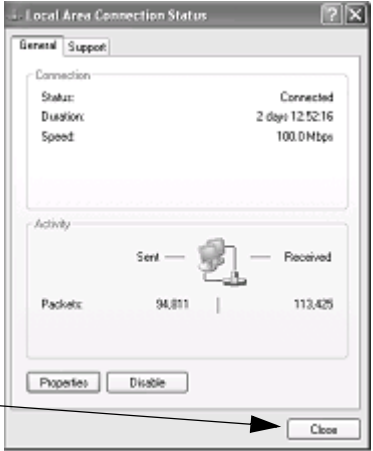

NOTE: THIS SCREEN MAY NOT BE DISPLAYED

## Using IPCONFIG To Verify Ethernet Settings

---

This section is used to verify that the local Ethernet port of the PC is configured properly. In this section a detailed description of the use of the IPCONFIG utility is demonstrated.

### STEP 1

From the START menu click on the RUN operation.



### STEP 2

The RUN command entry box will appear. Enter CMD into the open field of this window then click the OK Button. This will allow the user access to the command line entry prompt of WINDOWS.

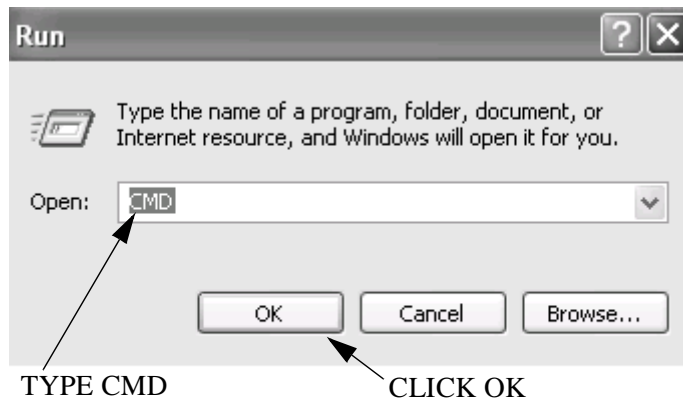

**STEP 3**

At this point the command line entry is displayed. At the Command Prompt type IPCONFIG and then press the ENTER key of the keyboard.

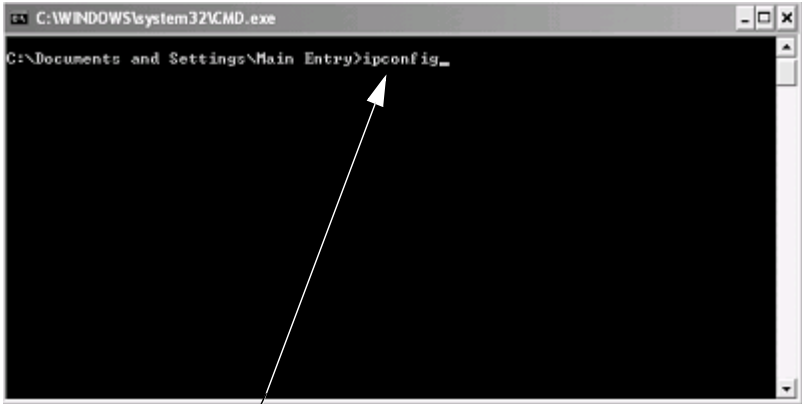

Type IPCONFIG then press the ENTER key

The Ethernet parameters of the PC's Ethernet port will be displayed. Verify that the IP address and Subnet mask match the entries previously entered. If the parameters do not match:

- Verify that the parameters were entered correctly in the Network Properties window from the previous procedure.
- Reboot the PC and repeat this procedure.

**Note:** If the user is unable to successfully set the Ethernet parameters please consult the facility IT department or network administrator.

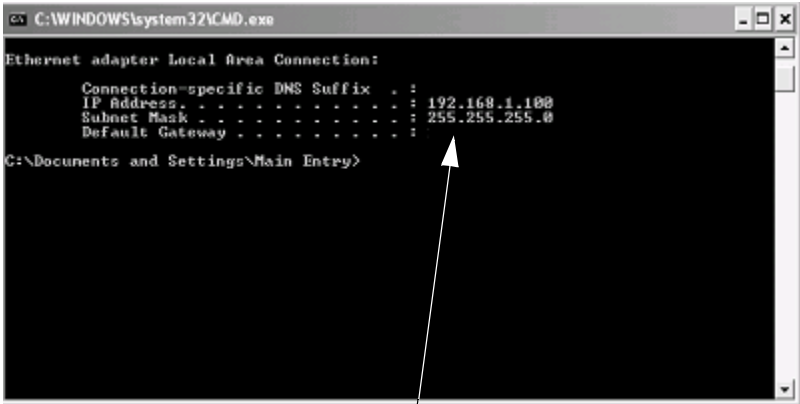

Ethernet Parameters for Local Port

## Connecting The PC To The Marquee

### Cable Description

This section discusses the steps to connect the Marquee directly to the PC.

There are two types of Ethernet cables available in today's market.

A patch or straight cable is used when connecting an Ethernet device to a Switch or HUB.

A Cross Over cable is used when connecting one Ethernet Device, such as a PC, to another Ethernet Device, such as the Marquee, without a HUB or Switch. This is known as a direct connection and requires that the Ethernet cable crosses the Ethernet signals. A Cross Over cable is included with the Marquee for this purpose. If the user is connecting the Marquee to a HUB or Switch, the user must supply the Patch or Straight Through cable.

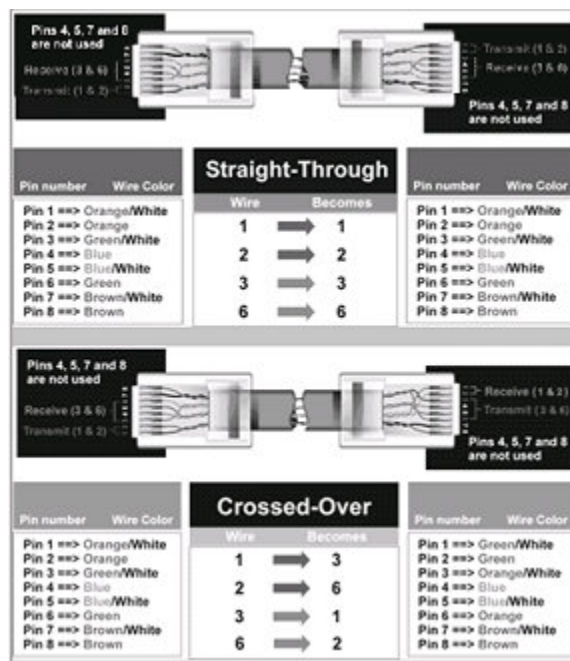

**Figure 1—Ethernet Cable Pinouts**

### Connecting the Ethernet Cable

Prior to connecting the Marquee to the PC, both the PC and Marquee should be powered down.  
Connect the Cross cable to the Ethernet port of the marquee. The Ethernet port is located on the right side of the Marquee.

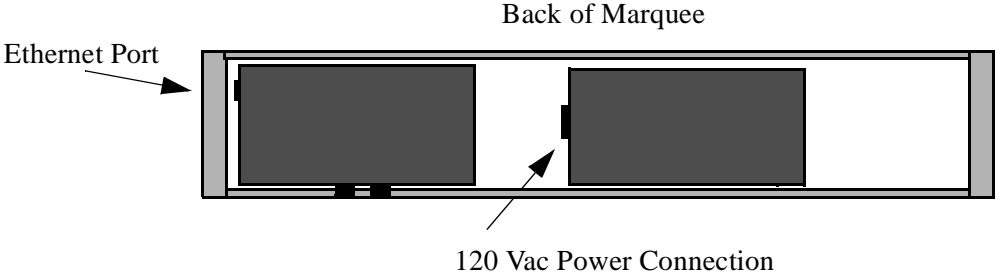

Connect the other end of the Cross cable to the PC's Ethernet Port.

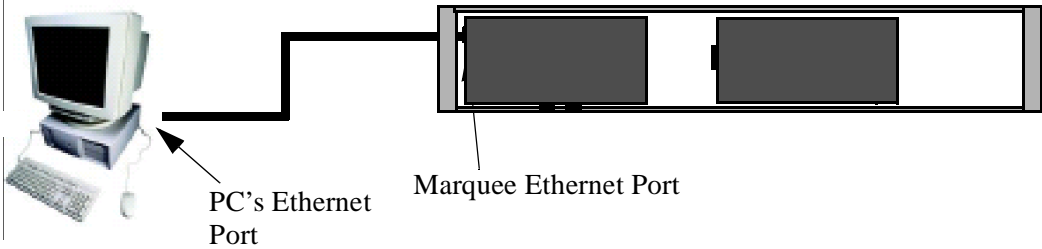

Power up both the PC and Marquee. After the PC has booted the user should check for the LINK light of the PC's Ethernet port is lit. The LINK light is lit when a physical connection is made between the PC's ethernet port and another Ethernet device, such as the Marquee. If the LINK light is lit then the PC is properly connected to the Marquee.

If the LINK light is not lit check the following:

- Verify the Marquee is powered
- Verify the cable is a cross over cable
- Verify the Ethernet port of the PC is Enabled

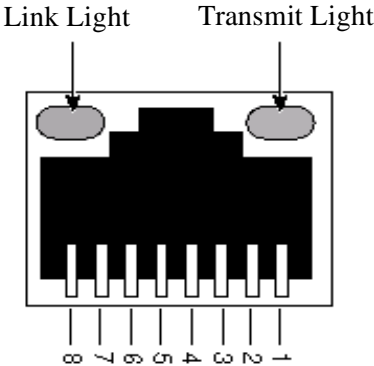

## Verifying Ethernet Communications

---

The previous section verified the physical connection between the Ethernet port to the PC and the Marquee. This section will be used to verify a communication connection exists between the Marquee and the PC.

In order to communicate to the Marquee a communication connection must be established. The physical connection indicates that communication can physically occur but does not verify that the Ethernet parameters match between the Marquee and the PC. This section is used to verify the Ethernet Parameters of both the PC and Marquee.

### STEP 1

On the PC, click START followed by RUN.



## STEP 2

The RUN command entry box will appear. Enter CMD into the open field of this window then click the OK Button. This will allow the user access to the command line entry prompt of WINDOWS.

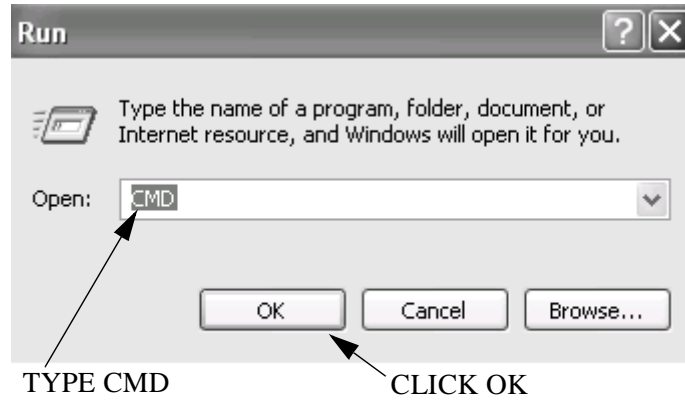

## STEP 3

At this point the command line entry is displayed. At the Command Prompt type PING 192.168.1.200 and then press the ENTER key of the keyboard. This operation sends a low level command to verify that communications can be established. The following screen shots display the three different responses that may occur during this operation along with a description of the response.

### Reply From

This is an indication that Ethernet communication is established to the Marquee. Proceed to next section.

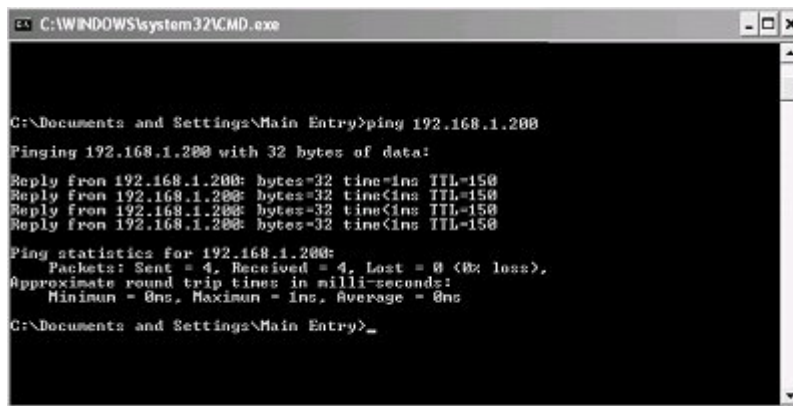

## Request timed out

This indicates that a connection to the Marquee could not be established.

- Verify the IP address and Subnet Mask is correct on the Marquee
- Verify cabling and LINK light is lit
- Verify Ethernet settings of PC

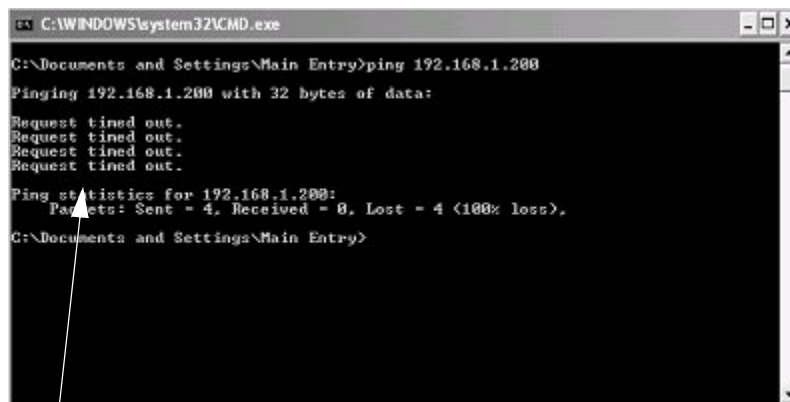

```
C:\WINDOWS\system32\CMD.exe
C:\Documents and Settings\Main Entry>ping 192.168.1.200
Pinging 192.168.1.200 with 32 bytes of data:
Request timed out.
Request timed out.
Request timed out.
Request timed out.
Ping statistics for 192.168.1.200:
    Packets: Sent = 4, Received = 0, Lost = 4 (100% loss),
C:\Documents and Settings\Main Entry>
```

Response

## Destination Host Unreachable

This is an indication that the PC's Ethernet settings are not correct. This is a common error when the IP address or Subnet mask is set incorrectly.

- Verify the PC's Ethernet settings
- Reboot pc

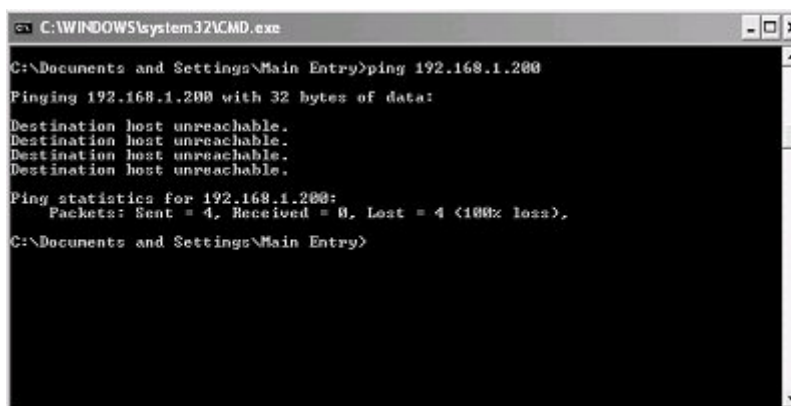

```
C:\WINDOWS\system32\CMD.exe
C:\Documents and Settings\Main Entry>ping 192.168.1.200
Pinging 192.168.1.200 with 32 bytes of data:
Destination host unreachable.
Destination host unreachable.
Destination host unreachable.
Destination host unreachable.
Ping statistics for 192.168.1.200:
    Packets: Sent = 4, Received = 0, Lost = 4 (100% loss),
C:\Documents and Settings\Main Entry>
```

## Connecting To the Marquee's WEB Server

---

In this section a detailed explanation of the steps that are used to access the built in WEB sever of the Marquee.

There are many different WEB browser software packages available on the market today. In this section a general overview of WEB browser settings is discussed. Most WEB browser support the settings discussed in this section, the user should reference documentation specific to the WEB browser that is being used to determine how settings are configured within a given WEB browser.

**Note:** In most cases no setting changes are required to the WEB browser. Only in specific cases is this required.

### Step 1

Start the WEB Browser on the PC.

### Step 2

In the Address Bar type HTTP://192.168.1.200.

**Note:** 192.168.1.200 is the default IP address of the Marquee. If this has been changed by the user, change the IP address to match the IP address of the Marquee.

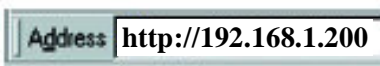

**Note:** On many browsers the **http://** is automatically added to the address so the user does not need to type it in.

### Step 3

At this point one of two items will be displayed in the WEB Browser.

#### Marquee's Monitor Screen Appears

This is an indication that the WEB browser has established a connection to the Marquee's WEB server. The user can now proceed to configure the Marquee.

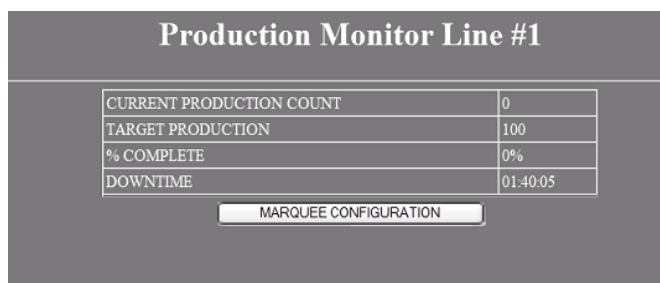
A screenshot of a web browser displaying a 'Production Monitor Line #1' screen. The screen has a dark grey background with white text. At the top, it says 'Production Monitor Line #1'. Below that is a table with four rows: 'CURRENT PRODUCTION COUNT' (0), 'TARGET PRODUCTION' (100), '% COMPLETE' (0%), and 'DOWNTIME' (01:40:05). At the bottom of the screen is a button labeled 'MARQUEE CONFIGURATION'.

Production Monitor Line #1	
CURRENT PRODUCTION COUNT	0
TARGET PRODUCTION	100
% COMPLETE	0%
DOWNTIME	01:40:05

MARQUEE CONFIGURATION

## No Monitor Page is Displayed

The Monitor page is not displayed and a message such as WEB PAGE CAN NOT BE LOADED or FOUND. This error can be caused by the WEB browser's settings not being configured properly. The most common reasons for this error are listed below.

**Note:** It is assumed the user has followed the proceeding sections to verify Ethernet communication to the Marquee. If not please refer to these sections to verify that the Ethernet settings of the PC are correct.

## WEB browser using wrong Ethernet Connection

In many PCs, such as a laptop, more than one Ethernet connection exists. In many cases a wireless Ethernet connection exist on the PC and because of this the WEB browser uses this connection as the default Ethernet Connection.

The solution for this is to DISABLE all Ethernet connections except the LOCAL Ethernet port.

### STEP 1

Click on START followed by Control Panel.

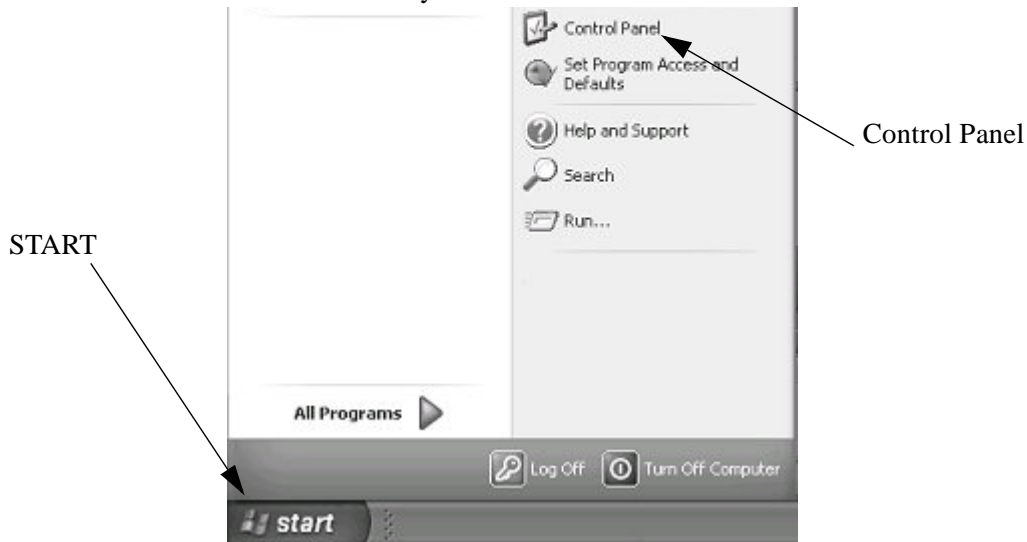

### STEP 2

Click on NETWORK CONNECTIONS.



**STEP 3**

Right click on each Network connection other than the LOCAL CONNECTION and select DISABLE.

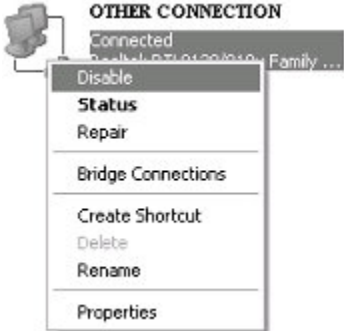

**STEP 4**

Restart PC and then restart the WEB browser.

**WEB Browser Using Proxy server**

In many facility networks, the WEB browser does not make a direct connection to the Internet. In these cases a PROXY server is connected to the network and the WEB server connects to this PROXY server to access WEB pages. When directly connecting to a WEB server, such as the Marquee this setting within the WEB browser must be turned off. Follow these steps to disable the PROXY server.

**STEP 1**

Open the WEB browser.

**STEP 2**

Within the WEB browser select TOOLS followed by INTERNET OPTIONS

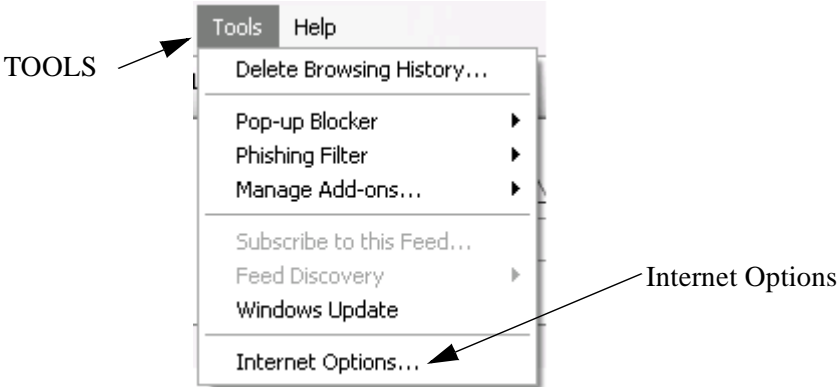

## Making The Ethernet Connection

### Detailed Ethernet Setup

#### STEP 3

The following screen will be displayed. Select the CONNECTIONS TAB. Followed by clicking on LAN SETTINGS.

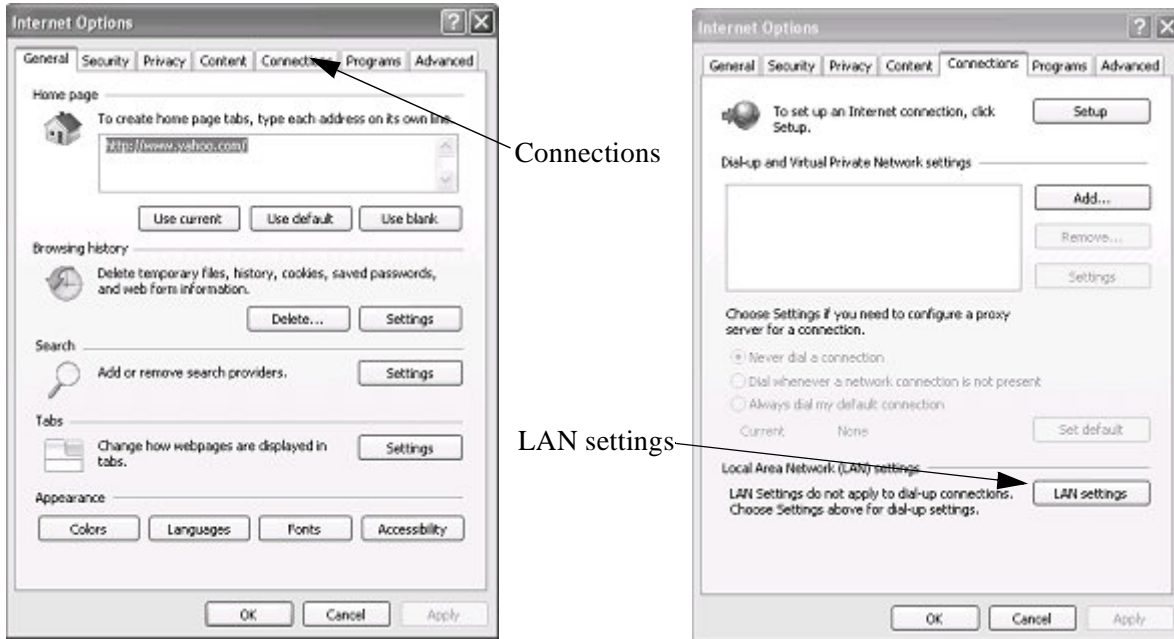

#### STEP 4

IF selected, deselect PROXY SERVER. Click OK on all windows and restart the WEB BROWSER.

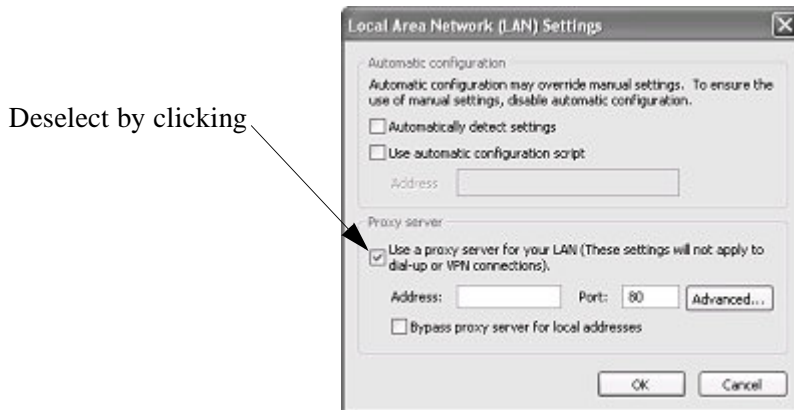

## Marquee WEB Pages

This chapter discusses the WEB page configuration menus of the Marquee. The Marquee has a built in WEB server so as the user may use any WEB browser to open the configuration pages and configure the Marquee for the application at hand. This chapter is designed to give in depth information about each configuration page. The next chapter gives the user sample setups that a user can use in order to accomplish some standard tasks.

### MONITOR PAGE

The Monitor page is the initial page that is displayed when the user opens a WEB browser and types in the IP address of the Marquee. The title and contents of this page are defined by the user on the MONITOR CONFIGURATION page. Up to 10 values and associated text can be configured by the user.

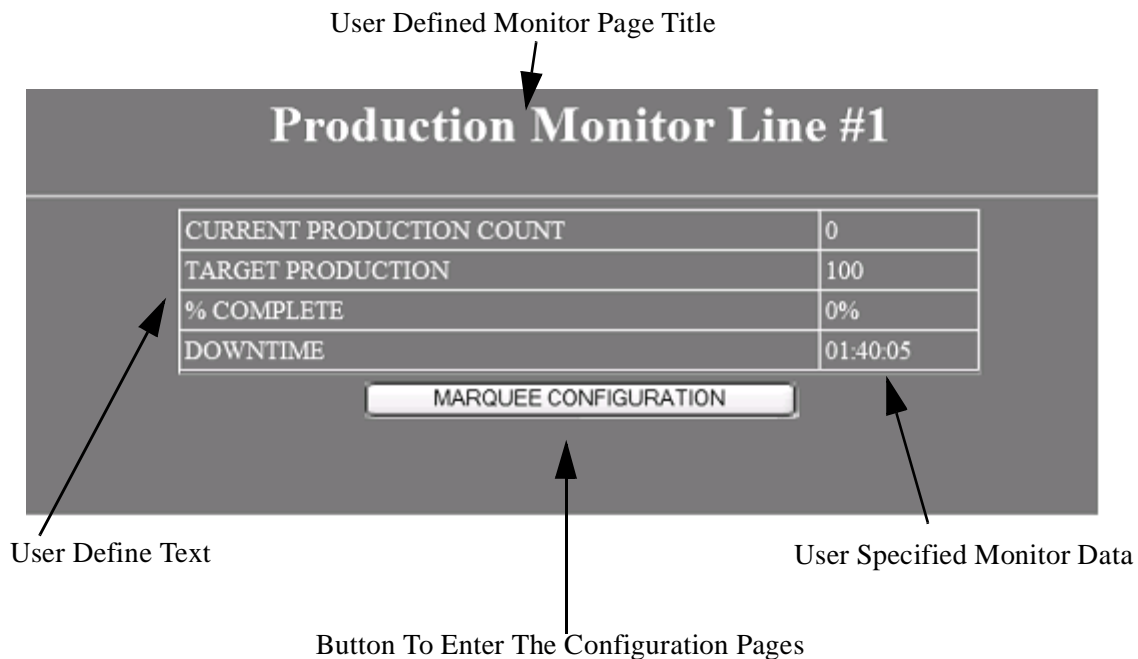

Figure 1—Monitor Page

## Access Configuration Pages

Access to the configuration pages is password protected. This feature allows only designated user the ability of changing the Marquee configuration. To access the configuration pages click the MARQUEE CONFIGURATION button. A password entry screen will be displayed.

**Note:** The default user name is **admin** and the default password is **admin**. This may be changed in the NETWORK CONFIGURATION page.

**WARNING**—If the user name or password are changed please record the new setting and store them in a safe location for future reference.

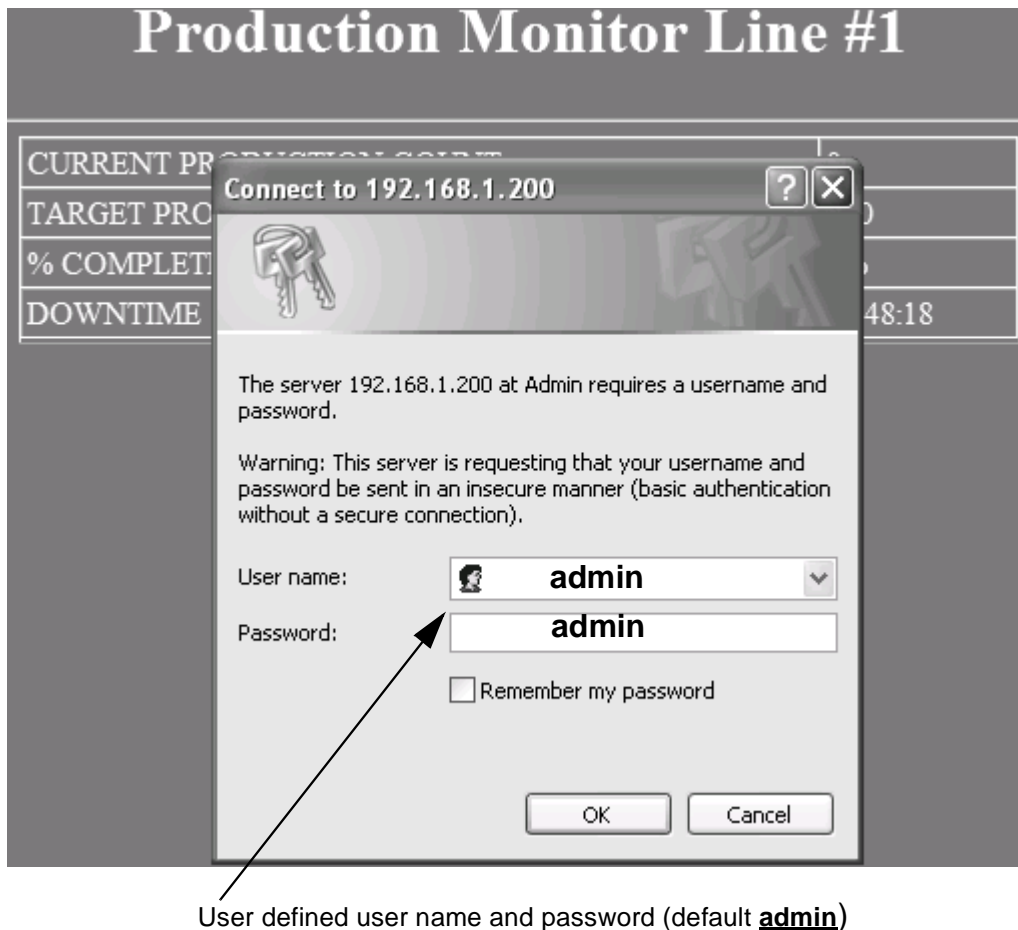
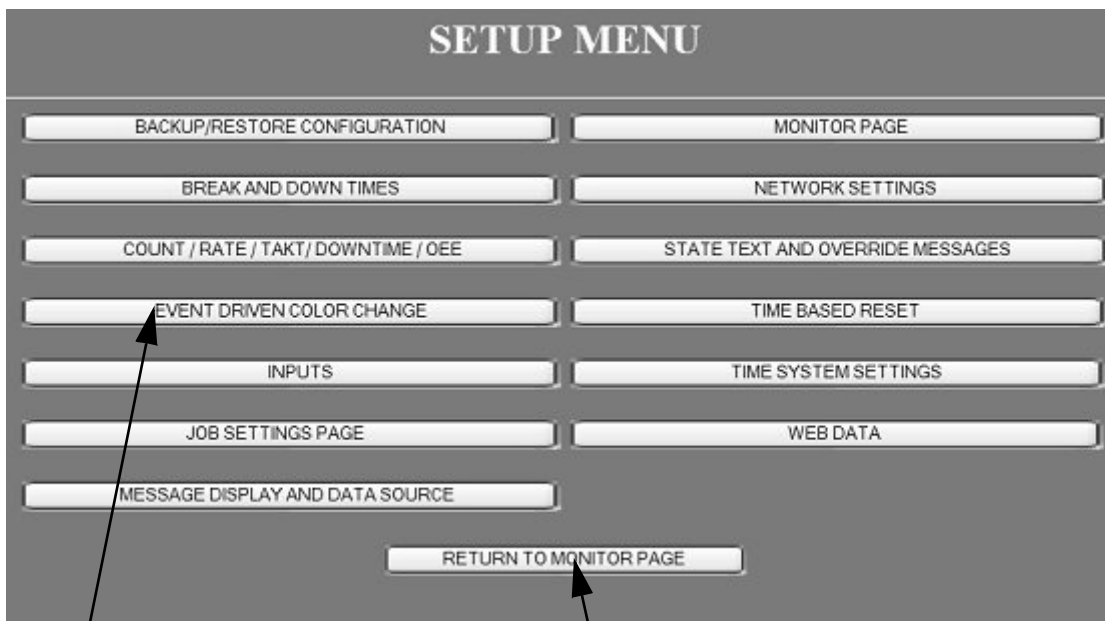

Figure 2—Password Entry Page

## SETUP MENU

The setup menu allows the user to access the Marquee configuration pages. This page consists of 13 configuration page access buttons and a return button.



Access to Configuration Pages

Return to Monitor Page

**Figure 3—Setup Menu Page**

**Note:** A common operation within all configuration pages is that the APPLY button must be clicked prior to leaving the page in order for any changes that have been made to take affect. If the user leaves the page prior to clicking on the APPLY button any changes made on that page will be discarded.

## BACKUP/RESTORE CONFIGURATION

---

The BACKUP/RESTORE Configuration page is used to backup the current configuration of the Marquee to a file on the configuration PC or Restore a previous configuration to the Marquee.



### BROWSE Button

The BROWSE button is used when an existing configuration is to be RESTORED to the Marquee. By pressing this button an explorer window is opened to allow for selecting the file to restore to the Marquee.

**Note:** The file type/extension is always.CFG

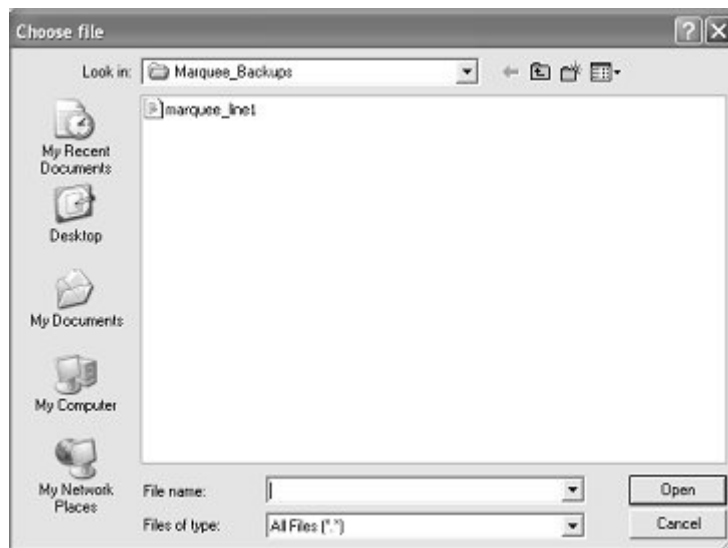

## RESTORE Button

Upon selecting the file to restore to the marquee, pressing the RESTORE button initiates the file transfer to the marquee.

**WARNING**—Restoring a file to the Marquee overwrites all configuration in the Marquee with the stored configuration within the file selected.

## BACKUP Button

The BACKUP button is used to read the configuration of the Marquee and save this configuration to a file on the configuration PC.

Upon clicking the BACKUP button a window appears to indicate a file download is being performed.

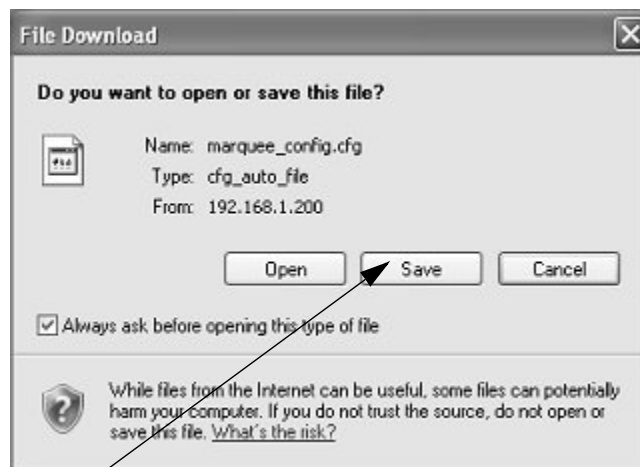

Selecting SAVE opened a windows browser that allows the name and storage location of the file to be specified.

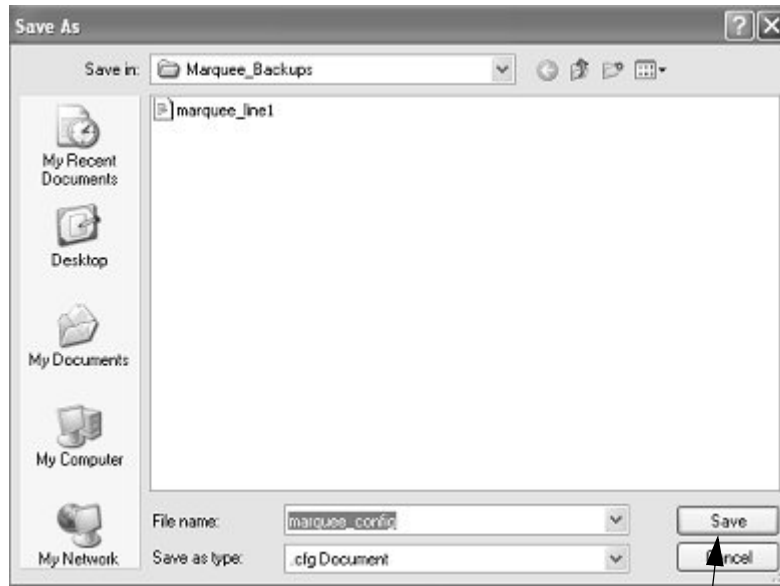

Once the file name and storage location are specified pressing the SAVE button will save the configuration file to disk.

## BREAK/DOWN TIMES CONFIGURATION

This configuration page is used to configure defined break or schedule machine down times.

PRODUCTION TIMES CONFIGURATION				
BREAKS/SCHEDULED DOWN TIMES				
ACTIVE	START TIME	END TIME	HOLD Takt Timer	NO DOWNTIME MONITORING
<input type="checkbox"/>	1:00 AM	1:15 AM	<input type="checkbox"/>	<input type="checkbox"/>
<input type="checkbox"/>	1:00 AM	1:15 AM	<input type="checkbox"/>	<input type="checkbox"/>
<input type="checkbox"/>	1:00 AM	1:15 AM	<input type="checkbox"/>	<input type="checkbox"/>
<input type="checkbox"/>	1:00 AM	1:15 AM	<input type="checkbox"/>	<input type="checkbox"/>
<input type="checkbox"/>	1:00 AM	1:15 AM	<input type="checkbox"/>	<input type="checkbox"/>
<input type="checkbox"/>	1:00 AM	1:15 AM	<input type="checkbox"/>	<input type="checkbox"/>
<input type="checkbox"/>	1:00 AM	1:15 AM	<input type="checkbox"/>	<input type="checkbox"/>
<input type="checkbox"/>	1:00 AM	1:15 AM	<input type="checkbox"/>	<input type="checkbox"/>
<input type="checkbox"/>	1:00 AM	1:15 AM	<input type="checkbox"/>	<input type="checkbox"/>
<input type="checkbox"/>	1:00 AM	1:15 AM	<input type="checkbox"/>	<input type="checkbox"/>
<input type="checkbox"/>	1:00 AM	1:15 AM	<input type="checkbox"/>	<input type="checkbox"/>
<input type="checkbox"/>	1:00 AM	1:15 AM	<input type="checkbox"/>	<input type="checkbox"/>
<input type="checkbox"/>	1:00 AM	1:15 AM	<input type="checkbox"/>	<input type="checkbox"/>
<input type="checkbox"/>	1:00 AM	1:15 AM	<input type="checkbox"/>	<input type="checkbox"/>
<input type="checkbox"/>	1:00 AM	1:15 AM	<input type="checkbox"/>	<input type="checkbox"/>

Apply Changes

Figure 4—Scheduled Break/Down Times

### ACTIVE

This checkbox is used to specify that the defined start and end time is active and appropriate action will take place.

### START TIME

In AM/PM format the user specifies the start of the break/down time. When the clock of the Marquee matches this time, then the Marquee will be placed in break time mode. If the break time override message is active, the break time message will appear on the Marquee.

### END TIME

This field marks the end of the break time. At the point at which the Marquee time matches this field the Marquee will exit break mode and return to the current mode of the machine.

### HOLD Takt Timer

If selected the Takt Timer will cease to run and hold it's current value from start time to end time. This causes the TARGET COUNTER to stop incrementing to indicate the system is in break.

### NO DOWNTIME MONITORING

If selected then during the time between start and end the Marquee will not accumulate DOWN TIME.

## OEE/COUNT/RATE/TAKT TIMER/DOWNTIME

This configuration page is used to count scale factors, Takt Timer and Target Counter settings, Downtime condition and Rate parameters.

COUNT/RATE/TAKT/DOWNTIME/OEE CONFIGURATION

COUNT/RATE PARAMETERS

SCALE FACTOR	RESULT DIVIDER	SAMPLE PERIOD (SEC)	RATE TIME OUT (SEC)	RATE ROUNDING
1	1	5	10	100's ▾

TAKT TIMER/TARGET COUNTER (OEE PERFORMANCE) CONFIGURATION

TIME INTERVAL (SEC)	VALUE PER INTERVAL	RESTART AFTER RESET	HOLD TIMER IF IN SETUP	HOLD TIMER IF DOWN
5	10	<input type="checkbox"/>	<input type="checkbox"/>	<input type="checkbox"/>

DOWNTIME CONFIGURATION

MACHINE DOWNTIME WILL BE BASED ON IF MACHINE RUN INPUT IS NOT ON ▾

Figure 5—COUNT/RATE/TAKT TIMER /DOWNTIME

### COUNT/RATE PARAMETERS

#### SCALE FACTOR

The count SCALE FACTOR is used to define for each transition of the count input what the value of to increase TOTAL COUNT. An example would be if the count input was triggered from a case of 12 products being completed and the user wished to count the total number of products rather than number of cases the count scale factor would be 12. This in turn would add 12 to the total count on each transition of the input.

#### RESULT DIVIDER

The RESULT DIVIDER is used to define the number transition of the count input that is required to result in a TOTAL COUNT being increased by 1. An example would be, if the COUNT input is being triggered off a gear with 40 teeth and 1 rotation of this gear produced 1 part then the RESULT DIVIDER would be 40. This would require 40 transitions of the COUNT INPUT to occur before the TOTAL COUNT would be increased by 1.

#### SAMPLE PERIOD

The sample period field is used to specify the length of time to read count pulse from the count input to determine machine rate. Please note that the larger this value the better resolution will be but the slower the update of the data will occur.

## RATE TIME OUT

This field is used to specify the time to wait for the next count input. If the count input does not activate within this time period the machine rate will be set to 0. This field should always be larger than the SAMPLE PERIOD field's value.

## RATE ROUNDING

This selection box is used to select rounding of the RATE parameters. This is useful when variations in machine speed cause the RATE display to fluctuate. The rate displayed will be rounded to the selected rounding location (1's,10's,100's, etc.).

## TAKT TIMER/TARGET COUNTER (OEE PERFORMANCE) CONFIGURATION

### TIME INTERVAL

This field allows the user to specify the Takt Timer time set point. The Takt timer will start at this value and upon completion will increase the value of the TARGET COUNTER. This field should be set to the expected time to complete a giving product/process.

### VALUE PER INTERVAL

This field is used to specify the amount to increase the TARGET COUNTER each time the Takt Timer elapses. This is used when the Takt Timer is used to specify more than the time to complete a single product.

### RESTART AFTER RESET

This option allows the Takt Timer to restart at the specified time interval after a reset. If this option is not selected then the Takt Timer will stay at the current value after a reset.

### HOLD TIMER IF IN SETUP

This option allows the user to specify how the Takt Timer operates during a machine setup mode. If selected, the Takt Timer will stop timing during a machine SETUP.

### HOLD TIMER IF DOWN

This option allows the user to specify how the Takt Timer operates during a machine DOWN state. If selected, the Takt Timer will stop timing during a machine DOWN state.

## DOWNTIME CONFIGURATION

This section allows the user to specify the monitor condition for downtime monitoring. There are 2 conditions that can be monitored to determine if the machine is DOWN.

### MACHINE RUN INPUT NOT ON

If this condition is selected then the user must supply a MACHINE RUN input. If the MACHINE RUN INPUT is not active then the machine is considered DOWN and DOWNTIME will be incremented.

### RATE = 0

If this condition is chosen as the condition to determine if the machine is down, then if the production rate every equals zero than DOWNTIME is accumulated.

## EVENT DRIVEN COLOR CHANGE

This page is used to configure the variable color change functions. Variable color change is used when the color of text or data field of the Marquee needs to change colors based on the value of a given variable such as %COMPLETE or BAD COUNT.

VARIABLE COLOR CONFIGURATION					
INDEX	VARIABLE	DEFAULT	IF >= COLOR		IF >= COLOR
1	TOTAL COUNT	RED	0	RED	0 RED
2	TOTAL COUNT	RED	0	RED	0 RED
3	TOTAL COUNT	RED	0	RED	0 RED
4	TOTAL COUNT	RED	0	RED	0 RED

### INDEX

There are 4 variable color indexes. This field displays the index number associated with this configuration.

### VARIABLE

This selection is used to select the variable whose value will be used to determine the color for this index. Example if TOTAL COUNT is selected as the variable, the value of TOTAL COUNT will be used to determine the color of this index. For a complete description of each variable selection choice please refer to the chapter AVAILABLE PROCESS VALUES

### DEFAULT

This is the default color for the index. If neither of the other color change conditions are true than this is the color to be used.

### IF >= COLOR

If the value of the selected variable is greater than or equal to the value specified then the color specified will be used for this index.

## INPUT CONFIGURATION

This page allows the user to configure the inputs of the Marquee. Each of the six inputs can be configured to accomplish any task the Marquee requires.

Figure 6— Input Configuration Page

**Note:** The user should avoid configuring more than one input for any giving operation. If more than one input is configured for a single operation, only the higher numbered input will control that operation and the lower numbered input configuration will be ignored.

### GOAL COUNT PER SHIFT

This data entry field is used to set the GOAL that can be displayed and is also used to perform such calculations as %COMPLETE. This value can also be enter by the IR remote and on the MESSAGE AND DATA CONFIGURATION page.

### INPUT CONNECTIONS

In this section the 3 inputs of the Marquee can be configured for their operation and active state. This area is broken up into four sections, one for each input. The input number corresponds to the pin on the input connectors. Refer to the chapter INPUTS for the physical connections.

Table 1—Input Locations

Input #	Input Connector Number	Pin
1	1	4
2	1	2
3	1	5
4	2	4

**Table 1—Input Locations**

Input #	Input Connector Number	Pin
5	2	2
6	2	5

**INPUT SIGNAL**

Input number 1 is dedicated to be the count input. The user can configure the de-bounce time for this input. The de-bounce time allows the use of such devices as push buttons and reed switches to be used and will ignore any pulse less than the de-bounce time setting.

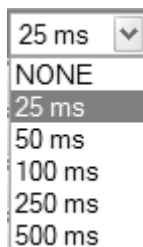

This field allows the user to specify the given input to it's operation for the Marquee.

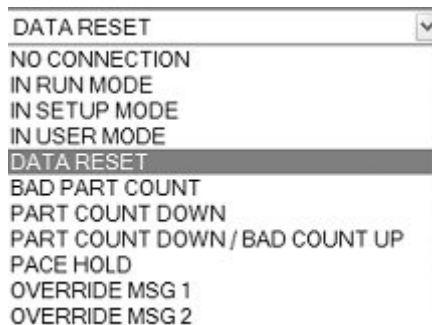

Table 2—Input Signals Description

SIGNAL	DESCRIPTION
NO CONNECTION	No operation
IN RUN MODE	Signals the Marquee that the machine is running. This signal is used to calculate values such as DOWNTIME, RUNTIME, etc. As long as this input is active the machine is considered to be running.
IN SETUP MODE	Signals the Marquee that the machine is in SETUP mode. This signal is used to calculate the value of SETUP TIME. As long as this input is active the machine is considered to be in SETUP.
IN USER MODE	Signals the Marquee that the machine is in a USER DEFINED mode. This signal is used to calculate the value of USER TIME. As long as this input is active the machine is considered to be in USER MODE.
DATA RESET	On the transition from not active to active, the production values such as TOTAL COUNTER, DOWNTIME, BAD COUNTER etc. are reset to a value of 0.
BAD PART COUNT	On the transition from not active to active, the value specified in the COUNT UP field is added to the BAD COUNTER.
PART COUNT DOWN	On the transition from not active to active, the value specified in the COUNT DOWN field is subtracted from the TOTAL COUNTER.
PART COUNT DOWN/BAD COUNT UP	On the transition from not active to active, the value specified in the COUNT DOWN field is subtracted from the TOTAL COUNTER and the value specified in the COUNT UP field is added to the BAD COUNTER.
PACE HOLD	If active, stops the Takt timer so as the Target Count value does not increase. Used to not increase Target Counter value during breaks.
OVERRIDE MSG 1	If this input is active the text configured for override message 1 will be displayed.
OVERRIDE MSG 2	If this input is active the text configured for override message 2 will be displayed.

**Note:** For a complete description of the production variables such as TOTAL COUNT please refer to the chapter AVAILABLE PROCESS VALUES.

## ACTIVE STATE

The active state field is used to specify the state at which the input is considered active. The inputs on the Marquee required a 24 Vdc PNP signal in order to turn ON. This field does not change the input requirements but changes the state at which the input is to be considered active.

ACTIVE HIGH   
ACTIVE HIGH  
ACTIVE LOW

**Table 3—Active State Description**

Selection	Description
ACTIVE HIGH	The input is considered active if 24Vdc is present on the input pin.
ACTIVE LOW	The input is considered active if 24Vdc is not present on the input pin.

## JOB SETTINGS PAGE

The JOB SETTINGS page allows the user to configure settings that can be accessed from the monitor page without the need for the administrator password. This functionality gives an operator the ability to change predefined operations of the Marquee.

JOB PAGE CONFIGURATION		
ACTIVATE JOB SETTINGS PAGE <input type="checkbox"/>		
SETPPOINTS AVAILABLE ON JOB SETTINGS PAGE		
SETTING	ACTIVE	OPERATOR DESCRIPTION
COUNT RESET	<input checked="" type="checkbox"/>	OPERATOR TEXT
GOAL COUNT	<input checked="" type="checkbox"/>	OPERATOR TEXT
TAKt TIMER TIME INTERVAL	<input checked="" type="checkbox"/>	OPERATOR TEXT
TARGET COUNTER VALUE PER INTERVAL	<input checked="" type="checkbox"/>	OPERATOR TEXT
TARGET RATE	<input checked="" type="checkbox"/>	OPERATOR TEXT
RATE SAMPLE PERIOD	<input checked="" type="checkbox"/>	OPERATOR TEXT
RATE TIMEOUT	<input checked="" type="checkbox"/>	OPERATOR TEXT
LINE 1 TEXT	<input checked="" type="checkbox"/>	OPERATOR TEXT
LINE 2 TEXT	<input checked="" type="checkbox"/>	OPERATOR TEXT
LINE 3 TEXT	<input checked="" type="checkbox"/>	OPERATOR TEXT
LINE 4 TEXT	<input checked="" type="checkbox"/>	OPERATOR TEXT
DUAL MODE LINE 1 TEXT	<input checked="" type="checkbox"/>	OPERATOR TEXT
DUAL MODE LINE 2 TEXT	<input checked="" type="checkbox"/>	OPERATOR TEXT
DUAL MODE LINE 3 TEXT	<input checked="" type="checkbox"/>	OPERATOR TEXT
DUAL MODE LINE 4 TEXT	<input checked="" type="checkbox"/>	OPERATOR TEXT

Figure 7—JOB SETTINGS PAGE

### ACTIVATE JOB SETTINGS PAGE

By selecting this checkbox a button will appear on the Monitor page that allows a user to ability to make changes to the Marquee configuration without a password. The user presses the JOB SETTINGS button and is forwarded to the JOB SETTINGS page. Only the items selected as active within this configuration will be presented to the user.

### SETTING

This is the description of the setting that may be presented to the user on the JOB SETTINGS PAGE.

## ACTIVE

If this checkbox is checked the operator will have access to the corresponding setting on the JOB SETTINGS page.

## OPERATOR DESCRIPTION

This is user defined text that will be displayed on the JOB SETTINGS PAGE. This allows the user to be specific about the setting that a operator will have access to. For example, if the user wishes to allow the operator to change the GOAL set point. But GOAL may mean nothing to the operator so the user places the text “ENTER QUANTITY REQUIRED” in the user text field. When the operator goes to the JOB SETTINGS page they will see this text along with the entry field.



The screenshot shows a web page titled "JOB SETTINGS PAGE". Below the title is a section labeled "JOB SETTINGS". Inside this section, there is a text input field containing the text "ENTER QUANTITY REQUIRED" and a numeric input field containing the value "100". Below the input fields is a button labeled "Apply Changes". At the bottom of the page is a button labeled "RETURN TO MONITOR PAGE".

## MESSAGE DISPLAY AND DATA SOURCE

This page allows the configuration of the text and data that will be displayed on the Marquee. Each field within this page is described in detail on the following pages.

**MESSAGE AND DATA CONFIGURATION**

GOAL COUNT PER SHIFT : 100

CHARACTER HEIGHT 2\*4 LINES

**MARQUEE DISPLAY LINE CONFIGURATION**

LINE #	LINE USAGE	DATA FORMAT	LINE TEXT	TEXT COLOR	DATA SOURCE	DATA COLOR
1	TEXT & DATA	99999	TARGET	RED	GOAL	RED
2	TEXT & DATA	99999	ACTUAL	RED	TOTAL COUNT	RED
3	TEXT & DATA	99999	% COMPLETE	RED	GOAL	RED
4	TEXT & DATA	99999	DOWNTIME	RED	TOTAL COUNT	RED

**DUAL MESSAGE DISPLAY MODE CONFIGURATION**

LINE #	ACTIVE	LINE USAGE	DATA FORMAT	LINE TEXT	TEXT COLOR	DATA SOURCE	DATA COLOR
1	<input type="checkbox"/>	TEXT & DATA	99999	% COMP	RED	TARGET COUNTER	RED
2	<input type="checkbox"/>	TEXT & DATA	999.99	DNTIME	RED	RUN TIME	RED
3	<input type="checkbox"/>	TEXT & DATA	99999	LINE 3	RED	TARGET COUNTER	RED
4	<input type="checkbox"/>	TEXT & DATA	999.99	LINE 4	RED	RUN TIME	RED

MESSAGE CYCLE TIME FOR DUAL MODE (in seconds) : 5

Figure 8—Message And Data Display Configuration Page

### GOAL COUNT PER SHIFT

This data entry field is used to set the GOAL that can be displayed and is also used in perform such calculations as % complete. This value can also be entered by the IR remote and on the INPUT CONFIGURATION page.

### CHARACTER HIEGHT

This selection is used to determine the character size to be used for the Marquee. The display can be used in either 2", 3" or 4" mode.

**Note:** 3" mode is only available on PM-0420. Field is not present on PM-0113.

### MARQUEE DISPLAY LINE CONFIGURATION

This area of the page is used to configure the text and data that will be displayed on the Marquee. This area is broken up into up to four, based on display, sections/rows, LINE# 1, LINE #2, LINE #3 and LINE# 4. LINE #1 is the top line of the Marquee, the data/text specified in this section/row will only effect the top line of the Marquee. LINE #2 next row and so on.

## LINE USAGE

LINE USAGE is used to set the Marquee line operation. The user has three options to choose from.

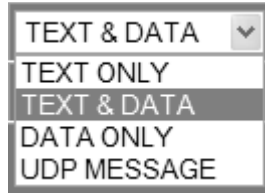

**Table 4—LINE USAGE Description**

SELECTION	DESCRIPTION
<b>TEXT ONLY</b>	Line will be used for Text display only. With this selection the LINE TEXT field is the only field that is valid. Selections in all other fields are ignored.
<b>TEXT AND DATA</b>	Line will display both Text and Data. With this selection all other fields are used to determine the text and data to display and how to display the data.
<b>DATA ONLY</b>	Line will display only Data. With this selection the entry within the field LINE TEXT is ignored.
<b>UDP MESSAGE</b>	Line will display the contents of the corresponding UDP port. This operation allows the user to send a UDP message to the display.  Line #1 UDP Port : 2010  Line #2 UDP Port: 2011  Line #3 UDP Port: 2012  Line #4 UDP Port: 2013

## DATA FORMAT

DATA FORMAT is used to set the length or display type for data that will be displayed. If a given line is to display both text and data, this selection is used in the determination of the maximum length of text that can be displayed. It is also used to determine the display format of certain data values (DOWNTIME, RUNTIME, DATE, TIME etc.).

9999  
 99999  
 999999  
 9999.9  
 999.99  
 HH:MM  
 MM:SS  
 HH:MM:SS  
 HH:MM AM/PM  
 MM:SS AM/PM  
 HH:MM:SS AM/PM  
 MM/DD  
 MM/DD/YY

**Table 5—DATA FORMAT Description**

SELECTION	DESCRIPTION	DISPLAY RANGE	MAX TEXT LENGTH
9999	Display data up to four digits. Should be used for % data types and also can be used if the value of such things as GOAL, COUNT etc. are going to be less than 10000.	0 - 9999	9 characters
99999	Display data up to five digits. Should be used if the value of such things as GOAL, COUNT etc. are going to be less than 100000.	0 - 99999	8 characters
999999	Display data up to six digits. Should be used if the value of such things as GOAL, COUNT etc. are going to be greater than 100000.	0 - 999999	7 characters
9999.9	Only to be used with CYCLE TIME variables. Allows the display of time to be in 10th of a second.	0.0-9999.9	8 characters
999.99	Only to be used with CYCLE TIME variables. Allows the display of time to be in 100th of a second.		8 characters
HH:MM	Display such things as DOWNTIME, RUNTIME etc. in the format of 2 digit hour and 2 digit minute.	00:00 - 99:99	8 characters
MM:SS	Display such things as DOWNTIME, RUNTIME etc. in the format of 2 digit minute and 2 digit second.	00:00-99:99	8 characters
HH:MM:SS	Display such things as DOWNTIME, RUNTIME etc. in the format of 2 digit hour, 2 digit minute and 2 digit second.	00:00:00 - 99:99:99	6 characters
HH:MM AM/PM	Display time in AM/PM format Hours and Minutes.	01:00 am - 12:59 PM	6 characters
MM:SS AM/PM	Display time in AM/PM format Minutes and Seconds.	00:00 am -59:59 pm	6 characters

**Table 5—DATA FORMAT Description**

<b>SELETCTION</b>	<b>DESCRIPTION</b>	<b>DISPLAY RANGE</b>	<b>MAX TEXT LENGTH</b>
HH:MM:SS AM/PM	Display time in AM/PM format Hours, Minutes and Seconds.	01:00:00 am - 12:59:59 pm	4 characters
MM/DD	Display DATE in the format 2 digit month, 2 digit day.	01/01 - 12/31	8 characters
MM/DD/YY	Display DATE in the format 2 digit month, 2 digit day and 2 digit year.	01/01/00-12/31/ 99	6 characters

## LINE TEXT

This field is used to specify that text to display on the given line number. This field is ignored if display type is selected as DATA ONLY.

**Note:** The DATA FORMAT selection is used to determine the maximum length of text that can be displayed. If the text entered is larger than what can be displayed the display will flash the field to indicate an overrun condition

## TEXT COLOR

This selection is used to specify the color that the text will be. The user may choose a fixed or variable based color for the Text of the display.

When using variable color the user must configure the variable color change attributes on the EVENT DRIVEN COLOR CHANGE page. These operations allow the text of the message to change colors based on the value of a giving process variable.



## DATA SOURCE

The DATA SOURCE field is used to specify where the data that is to be displayed will come from. This field is ignored if the display type has been selected to be TEXT ONLY. For a complete description of each data selection choice please refer to the chapter AVAILABLE PROCESS VALUES.

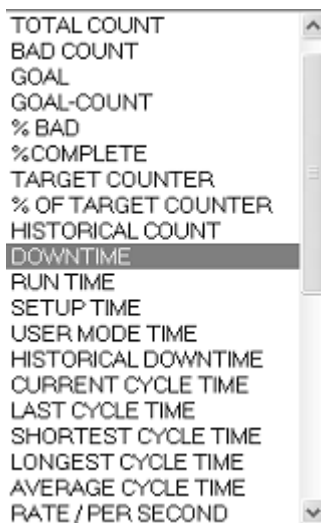

## DATA COLOR

This selection is used to specify the color that the process variable specified will be. The user may choose a fixed or variable based color for the data of the display.

When using variable color the user must configure the variable color change attributes on the EVENT DRIVEN COLOR CHANGE page. These operations allow the data field of the message to change colors based on the value of a given process variable.



## DUAL MESSAGE DISPLAY MODE CONFIGURATION

This area is used to configure the DUAL MODE operations of the display. DUAL MODE gives the user the capability to configure the Marquee to cycle the specified line between two user define text/data configurations. This operation allows the Marquee to display up to four different pieces of text and/or pieces of data. The basic operation is if the line is selected for DUAL MODE then the line will display the text/data from the MARQUEE DISPLAY LINE CONFIGURATION then after a user define time period the Marquee will display the text/data from the DUAL MESSAGE DISPLAY MODE CONFIGURATION for each line selected for this operation. This operation repeats cycling between the two configurations.

All fields within this section work identically to the field within the MARQUEE DISPLAY LINE CONFIGURATION with the exception of the ACTIVE field.

### ACTIVE FIELD

The ACTIVE field allows the user to select/deselect a given line to operate in DUAL MODE. If the check box is checked then that line will operate in DUAL MODE. If the check box is not checked then the given line will not operate in DUAL MODE.

### MESSAGE CYCLE TIME FOR DUAL MODE

This field allows the user to specify the message cycle time for any line that has been activated to be in DUAL MODE. The value specified here indicates the number of seconds between the line being changed to the next text/data.

EXAMPLE: If this setting is 5 and line 2 DUAL MODE is active. Line 2 will display the text/data from the MARQUEE DISPLAY LINE CONFIGURATION for 5 seconds. After this time period line 2 will display the configuration specified in the DUAL MESSAGE DISPLAY MODE CONFIGURATION line 2. After 5 seconds the line will revert back to the configuration in MARQUEE DISPLAY LINE CONFIGURATION. Line 1 will stay constant unless DUAL MODE is activated for line 1.

## MONITOR PAGE CONFIGURATION

This configuration page is used to configure the text and data that will be displayed on the MONITOR PAGE.

MONITOR PAGE TITLE :

MONITOR PAGE REFRESH RATE

MONITOR PAGE CONFIGURATION

LINE TEXT	LINE DATA
CURRENT PRODUCTION COUNT	TOTAL COUNT
TARGET PRODUCTION	GOAL
% COMPLETE	%COMPLETE
DOWNTIME	DOWNTIME
	NONE
	NONE
	NONE
	NONE
	NONE
	NONE

Figure 9—Monitor Configuration Page

### MONITOR PAGE TITLE

This field is used to enter the text that will be displayed as the title for the monitor page.

Production Monitor Line #1

CURRENT PRODUCTION COUNT	0
TARGET PRODUCTION	100
% COMPLETE	0%
DOWNTIME	01:40:05

## MONITOR PAGE REFRESH RATE

This field is used to specify the automatic refresh rate for the MONITOR page. The value entered in this field indicates how often to refresh the MONITOR page in seconds. If a user opens the MONITOR page in a WEB browser, the screen will automatically refresh at this rate.

## MONITOR PAGE CONFIGURATION

This section is used to configure both the text and data that will be displayed on the MONITOR page. The MONITOR page allows up to 10 lines of text/data to be displayed. This section is broken down into each line of the MONITOR page. The configuration of each lines text and data is user defined.

### LINE TEXT

This field is used to enter the text for a giving line of the MONITOR page. Each lines text is independent and not all lines are required to be configured.

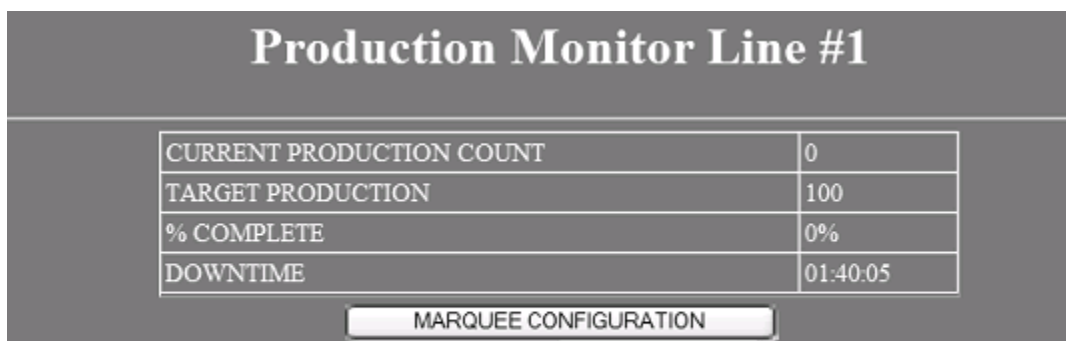

The screenshot displays a web interface for 'Production Monitor Line #1'. It features a table with four rows of production data and a button labeled 'MARQUEE CONFIGURATION' centered below the table.

Production Monitor Line #1	
CURRENT PRODUCTION COUNT	0
TARGET PRODUCTION	100
% COMPLETE	0%
DOWNTIME	01:40:05

MARQUEE CONFIGURATION

### LINE DATA

This field allows the user to select the production variable to be displayed in the data area of the MONITOR page for the given line. For a complete description of each data selection choice please refer to the chapter AVAILABLE PROCESS VALUES.

- TOTAL COUNT
- BAD COUNT
- GOAL
- GOAL-COUNT
- % BAD
- % COMPLETE
- TARGET COUNTER
- % OF TARGET COUNTER
- HISTORICAL COUNT
- DOWNTIME**
- RUN TIME
- SETUP TIME
- USER MODE TIME
- HISTORICAL DOWNTIME
- CURRENT CYCLE TIME
- LAST CYCLE TIME
- SHORTEST CYCLE TIME
- LONGEST CYCLE TIME
- AVERAGE CYCLE TIME
- RATE / PER SECOND

## Production Monitor Line #1

CURRENT PRODUCTION COUNT	0
TARGET PRODUCTION	100
% COMPLETE	0%
DOWNTIME	01:40:05

## NETWORK SETTINGS

---

This page is used to configure the Marquee's built-in ethernet network.

**Note:** If the Marquee is to be connected to the plant network, the IT department or network administrator of your facility should be consulted prior to assigning ethernet network parameters.

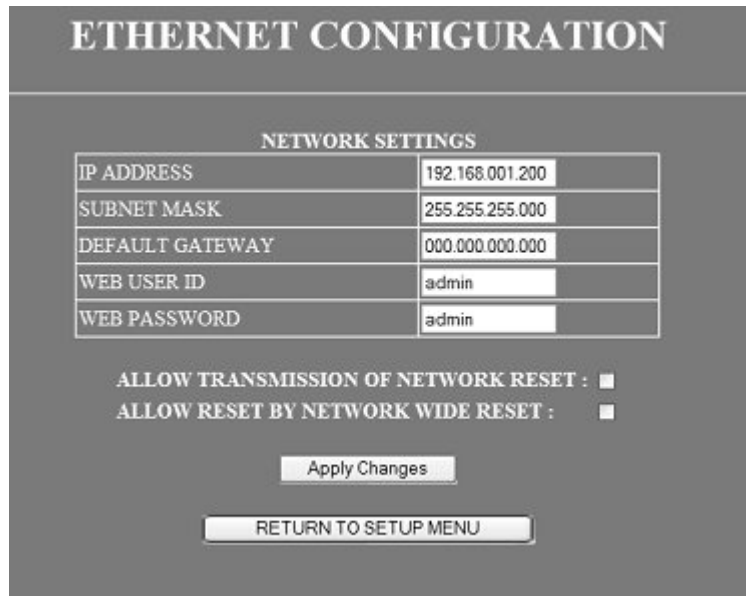

The screenshot displays the 'ETHERNET CONFIGURATION' page. At the top, the title 'ETHERNET CONFIGURATION' is centered. Below it, a section titled 'NETWORK SETTINGS' contains a table with five rows. The first row is 'IP ADDRESS' with the value '192.168.001.200'. The second row is 'SUBNET MASK' with '255.255.255.000'. The third row is 'DEFAULT GATEWAY' with '000.000.000.000'. The fourth row is 'WEB USER ID' with 'admin'. The fifth row is 'WEB PASSWORD' with 'admin'. Below the table, there are two checkboxes: 'ALLOW TRANSMISSION OF NETWORK RESET : ' and 'ALLOW RESET BY NETWORK WIDE RESET : '. At the bottom, there are two buttons: 'Apply Changes' and 'RETURN TO SETUP MENU'.

NETWORK SETTINGS	
IP ADDRESS	192.168.001.200
SUBNET MASK	255.255.255.000
DEFAULT GATEWAY	000.000.000.000
WEB USER ID	admin
WEB PASSWORD	admin

ALLOW TRANSMISSION OF NETWORK RESET :

ALLOW RESET BY NETWORK WIDE RESET :

Apply Changes

RETURN TO SETUP MENU

Figure 10—Ethernet Configuration Page

## NETWORK SETTINGS

This section is used to configure the Ethernet parameters and configuration page access parameters.

### IPADDRESS

This field is used to specify the IP address of the built-in ethernet port of the Marquee. If an invalid IP address is entered by the user it will be rejected when the APPLY button is clicked.

### SUBNET MASK

This field is used to specify the SubNet mask used by the built-in ethernet port of the Marquee. If an invalid SubNet mask is entered by the user it will be rejected when the APPLY button is clicked.

## DEFAULT GATEWAY

This field is used to specify the Default Gateway used by the built-in ethernet port of the Marquee. If an invalid Default Gateway is entered by the user it will be rejected when the APPLY button is clicked.

## WEB USER ID

This field is used to specify the user ID that is used when accessing the configuration pages of the MARQUEE.

**Note:** If a change is made to this field and then the APPLY button is clicked, the user will be disconnected from the Marquee. The user must then restart the browser and log back into the Marquee with the new WEB USER NAME and/or WEB PASSWORD to continue configuration.

## WEB PASSWORD

This field is used to specify the password that is used when accessing the configuration pages of the MARQUEE.

**Note:** If a change is made to this field and then the APPLY button is clicked, the user will be disconnected from the Marquee. The user must then restart the browser and log back into the Marquee with the new WEB USER NAME and/or WEB PASSWORD to continue configuration.

## ALLOW TRANSMISSION OF NETWORK RESET

This selection allows the user to specify whether or not the Marquee will broadcast a NETWORK RESET. If the check box is checked, the Marquee will broadcast a NETWORK RESET when a reset operation is encountered.

## HOW NETWORK RESET WORKS

If the user wishes the Marquee can broadcast a reset command to other Marquees that are connected to the same ethernet network. If the Marquee has been configured to broadcast a NETWORK RESET, then when a reset operation has been initiated on the Marquee the Marquee will broadcast a message over the Ethernet network that any Marquee that has been configured to ACCEPT NETWORK RESET will receive. Upon receiving this message these Marquees will reset the production value.

This feature allows a single Marquee to be the master reset for a network of Marquees.

EXAMPLE: The user has 10 production lines. At the end of a shift the production counts needs to be reset for all 10 production lines. By using the NETWORK RESET, the user only needs to initiate a reset signal to the one Marquee and all other Marquees on the network will be reset. This assumes that the other Marquees have been configured to accept the NETWORK RESET.

**Note:** NETWORK RESET can only reset other Marquees that are connected to the same Ethernet SubNet. NETWORK RESET is not sent through routers.

## ALLOW RESET BY NETWORK WIDE RESET

This selection is used to determine if the Marquee will except the NETWORK RESET command from other Marquees. If the check box is check, the Marquee will reset the production values when a NETWORK RESET is broadcasted by another Marquee.

## STATE TEXT AND OVERRIDE MESSAGES

This page allows the configuration of the machine state text and override messages.

State text is available for display or monitoring via the MACHINE STATE variable.

Override messages allow the display to display a message based on either the machine state, if a break time is occurring or if an input is assigned to display an override message.

STATE TEXT					
MACHINE STATE	DISPALYED TEXT				
RUNNING	RUN				
DOWN	DOWN				
IN SETUP	SETUP				
USER	STANDBY				

OVERRIDE MESSAGES					
DESCRIPTION	ENABLE	LINE 1 TEXT	LINE 2 USAGE	LINE 2 TEXT	COLOR
MACHINE DOWN	<input type="checkbox"/>	MACHINE IS DOWN	DURATION ACTIVE ▾	DOWN	RED ▾
IN SETUP MODE	<input type="checkbox"/>	MACHINE IN SETUP	DURATION ACTIVE ▾	SETUP	RED ▾
IN USER MODE	<input type="checkbox"/>	IN USER MODE	TEXT ▾	STANDBY	RED ▾
IN BREAK TIME	<input type="checkbox"/>	IN BREAK	TEXT ▾	TIME	RED ▾
OVERRIDE INPUT #1	<input type="checkbox"/>	OVER RIDE MESSAGE	TEXT ▾	MSG #1	RED ▾
OVERRIDE INPUT #2	<input type="checkbox"/>	OVER RIDE MESSAGE	DURATION ACTIVE ▾	MSG #2	RED ▾

Apply Changes

Figure 11—State Text and Override Messages

### STATE TEXT

This section is used to define what will be displayed for a giving machine state. The user supplies the text or value associated with the giving state.

STATE	DESCRIPTION
MACHINE RUNNING	MACHINE RUN input is active or part rate > 0 ( User selectable).
MACHINE DOWN	MACHINE RUN input is not active or part rate = 0 ( User selectable).
IN SETUP	IN SETUP MODE input is active.
IN USER MODE	IN USER MODE input is active.

Table 6— Machine STATES

## OVERRIDE MESSAGES

6 override messages exist to allow the display to change its display based on a given condition. The override messages are prioritized so as only one override message will be displayed if multiple conditions are active. The priority of the override messages goes from the first override message being the highest priority (MACHINE DOWN) to the last override message being the lowest priority (OVERRIDE MSG #2).

MESSAGE	CONDITION FOR DISPLAY
MACHINE DOWN	MACHINE RUN input not active or RATE = 0. (user configured)
IN SETUP MODE	SETUP MODE input active.
IN USER MODE	USER MODE input active.
IN BREAK TIME	A configured break time is active.
OVERRIDE MSG #1	OVERRIDE INPUT #1 is active.
OVERRIDE MSG #2	OVERRIDE INPUT #2 is active

**Table 7—OVERRIDE MESSAGES**

### ENABLE

The enable checkbox is used to allow operation of the corresponding override message. If the override message is enabled, when the condition comes true the corresponding text will be displayed on the Marquee.

### LINE 1 TEXT

User defined text to be displayed on line 1 of the Marquee.

### LINE 2 USAGE

There are two choices for the operation of the second line during a override message.

TEXT: Displays the text specified in LINE 2 TEXT on the second line of the Marquee.

DURATION ACTIVE: Displays the length of time that this override message has been active. In many cases the user may wish to know how long a condition such as DOWN has been active. To do this selection DURATION ACTIVE will cause the Marquee to display the length of time this message has been active.

### LINE 2 TEXT

If LINE 2 USAGE is set to TEXT then this is the text to display on the second line. If LINE 2 USAGE is set to DURATION ACTIVE this field is ignored.

## FLASH

If this checkbox is selected the override message will flash on the Marquee display. This can be used to bring attention to the condition that has caused the override message.

## TIME BASED RESET

This configuration page is used to configure shift start times. The user can configure up to 3 shift start times that will automatically reset the process variables within the Marquee.

SHIFT START/RESET TIMES			
ACTIVE	START TIME		RESET COUNTS
<input type="checkbox"/>	1:00	AM	<input type="checkbox"/>
<input type="checkbox"/>	1:00	AM	<input type="checkbox"/>
<input type="checkbox"/>	1:00	AM	<input type="checkbox"/>

Apply Changes

RETURN TO SETUP MENU

Figure 12—Time Based Reset

### SHIFT START/RESET TIMES

This field allows the configuration of up to 3 start of shift/reset times. The typical application is to use this to reset the counters and timers within the Marquee so as that any data viewed will be for the current production shift.

#### ACTIVE

This checkbox is used to activate or deactivate a given shift start time. If selected then this entry will be monitored for the time to occur and take appropriate action.

#### START TIME

In AM/PM format, the user specifies the time at which the shift starts. Entry format must be HH:MM.

#### RESET COUNTS

This selection indicates that at the given start time that all process variables within the Marquee will be cleared.

## TIME SYSTEM SETTINGS

---

This page is used to configure the Marquee's built-in real time clock and network time synchronization.

### TIME SYSTEM CONFIGURATION

TIME	<input type="text" value="19:37:54"/>	24 HOUR FORMAT HH:MM:SS
DATE	<input type="text" value="11/04/08"/>	FORMAT MM/DD/YY

#### DAYLIGHT SAVINGS CONFIGURATION

ENABLED <input checked="" type="checkbox"/>	MONTH	DAY	HOUR
START	<input type="text" value="3"/>	<input type="text" value="11"/>	<input type="text" value="2"/>
END	<input type="text" value="11"/>	<input type="text" value="4"/>	<input type="text" value="2"/>

ALLOW NETWORK TIME SYNC.

USE AS MASTER CLOCK (BROADCASTS TIME)  BROADCAST TIME EVERY  MINUTES

### TIME/DATE SETTING

This section allows the user to enter the current time and date in order to set the real time clock of the Marquee from the WEB interface.

#### TIME

This field is used to specify the current time in 24 hour format.

#### DATE

This field is used to specify the current date.

#### SET TIME/DATE

This button is used to initiate setting of the time and date of the Marquee's real time clock. Upon clicking this button the supplied time and date will be written to the Marquee's real time clock.

### DAYLIGHT SAVINGS CONFIGURATION

This section allows the setting of automatic daylight savings time.

### ENABLED

If this checkbox is checked, then the marquee will monitor for the month, day, and hour settings and will automatically adjust the real time clock accordingly.

### ALLOW NETWORK TIME SYNC.

This option allows the Marquee's real time clock to be synchronized to a master clock on the network. In order for this to operate, a marquee on the same network must be defined as a master clock. The master clock Marquee broadcasts a time sync message that any Marquee that is configured to ALLOW NETWORK TIME SYNC will receive the sync message and updates it's real time clock.

### USE AS MASTER CLOCK

This option is used to specify that this Marquee is the master clock on the network. In turn the Marquee will broadcast the current time and date to all other Marquees that are defined to receive the network time sync.

### BROADCAST TIME EVERY

If the Marquee is defined as the master clock, this selection allows the user to specify how often to transmit the time and date onto the network.

## WEB DATA CONFIGURATION

This page is used to configure the text and data that will transferred with WED DATA. For specific information on the operation and use of WEB DATA please refer to the chapter WEB DATA.

WEB DATA CONFIGURATION				
DESCRIPTION	DATA 1	DATA 2	DATA 3	DATA 4
Line 1	TOTAL COUNT	GOAL	%COMPLETE	DOWNTIME
	DATA 5	DATA 6	DATA 7	DATA 8
	NONE	NONE	NONE	NONE
	DATA 9	DATA 10		
	NONE	NONE		

## WEB DATA CONFIGURATION

In this section the user specifies the information that is used with WEB DATA.

### DESCRIPTION

This field is used to enter the text that will be sent via WEB DATA. The text that is entered in this field will accompany the data for WEB DATA.

### DATA 1 - DATA 10

These fields allow the user to specify the production values that will be used by WEB DATA. Up to 10 production values can be sent via WEB DATA to a remote PC for monitoring or data collection. For a complete description of each data selection choice please refer to the chapter AVAILABLE PRODUCTION VALUES.

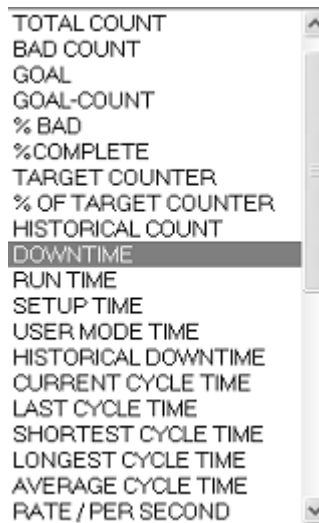



## —Chapter 5—

### Available Production Variables

This chapter describes the PRODUCTION VARIABLES that are available within the Marquee for monitoring and displaying. Each variable will be described along with the needed input configuration, if any, that is required in order to allow the operation of the variable. The table below is a quick reference to the variables and the values they hold.

**Table 1—Overview of Production Variables**

VARIABLE	DESCRIPTION
TOTAL COUNT	Number of parts counted since last reset
BAD COUNT	Number of bad parts counted since last reset
GOAL	User defined value for the total parts required to be completed
GOAL- COUNT	Difference between Goal and Total count. Parts remaining to be completed
%BAD	Percentage of total count that are bad/ not good
%COMPLETE	Percentage of goal complete
TARGET COUNTER	Calculated Target. aka Takt / Target Counter
% OF TARGET COUNTER	Percentage of target complete.
HISTORICAL COUNT	Total count prior to last reset.
DOWNTIME	Total time since last reset machine was not running
RUNTIME	Total time since last reset machine was running
SETUP TIME	Total time since last reset machine was in setup mode
USER MODE TIME	Total time since last reset machine was in user mode
HISTORICAL DOWNTIME	Total time machine was down prior to last reset
CURRENT CYCLE TIME	Time since last part was produced
LAST CYCLE TIME	Time to produce last part
SHORTEST CYCLE TIME	Shortest amount of time to produce a part since last reset
LONGEST CYCLE TIME	Longest time to produce a part since last reset
AVERAGE CYCLE TIME	The average cycle time for the last 25 machine cycles.
RATE /PER SECOND	Number of counts per second
RATE /PER MINUTE	Number of counts per minute
RATE /PER HOUR	Number of counts per hour
Takt TIME ELAPSED	Takt timer elapsed time

**Table 1—Overview of Production Variables**

VARIABLE	DESCRIPTION
Takt TIME REMAINING	Time remaining before Takt timer restarts
QUALITY	Percentage of good parts to bad parts produced
MACHINE AVAILABILITY	Percentage of time machine was in RUN mode since last reset
MACHINE PERFORMANCE	Percentage of parts produced compared to parts expected to be produced (TARGET COUNTER)
OEE	Overall Equipment Effectiveness QUALITY X AVAILABILITY X PERFORMANCE
MACHINE STATE	Current State of Machine (RUN/DOWN/SETUP/USER MODE)
MODBUS/TCP reg.40131	This variable receives it's value from a Modbus/TCP client writing to modbus register number 40131.
MODBUS/TCP reg.40133	This variable receives it's value from a Modbus/TCP client writing to modbus register number 40133.
MODBUS/TCP reg.40135	This variable receives it's value from a Modbus/TCP client writing to modbus register number 40135.
MODBUS/TCP reg.40137	This variable receives it's value from a Modbus/TCP client writing to modbus register number 40137.
MODBUS/TCP reg.40139	This variable receives it's value from a Modbus/TCP client writing to modbus register number 40139.
TIME	24 hour time from Marquee real time clock
DATE	Date of marquee real time clock

## TOTAL COUNT

---

This variable contains the number of parts/counts/cycles since the last Marquee reset operation.

### Configuration Requirements

In order for this variable to operate, the user must define one of the Marquee inputs to provide the PART COUNT UP signal.

On the transition from the input going from a non-active state to an active state the TOTAL COUNT variable's value will be increased.

### Configuration Options

The amount to increase the value of TOTAL COUNT on each transition is specified on the COUNT/RATE/TAKT/DOWNTIME/OEE CONFIGURATION page. The field SCALE FACTOR and RESULT DIVIDER in the COUNT/RATE PARAMETERS section of this page, allows the user to specify what value to add to the TOTAL COUNT on each transition of the PART COUNT UP (scale factor) input. Also a RESULT DIVIDER allows the user to only count a single count for multiple input transitions of the count input.

EXAMPLE 1: On each cycle of a machine 12 parts are produced. This user wishes to display the total parts produced from this machine. The user would set the SCALE FACTOR to 12. This causes the value of TOTAL COUNT to be increased by 12 on each transition of the PART COUNT UP input.

EXAMPLE 2: A 60 PPR encoder is connected to the count input, every 20 pulses equals 1 part being made. The user would set the RESULT DIVIDER to 20. This causes the value of TOTAL COUNT to be increased by 1 for every 20 pulses received on the count input.

COUNT/RATE PARAMETERS				
SCALE FACTOR	RESULT DIVIDER	SAMPLE PERIOD (SEC)	RATE TIME OUT (SEC)	RATE ROUNDING
1	1	2	4	1's 

## BAD COUNT

---

This variable contains the number of bad parts/ rejected parts since the last Marquee reset operation.

**Note:** If the application does not require QUALITY or %BAD then the BAD COUNT can be used as a second undefined counter.

**EXAMPLE:** The user does not wish to use the QUALITY or %BAD variables but wants to count the number of parts entering a machine and the number of parts exiting the machine. The user configures the Marquee's input signals PART COUNT UP and BAD PART COUNT. But in actuality the BAD COUNT is parts exiting the machine. Internally the Marquee does not care how this counter is used.

### Configuration Requirements

In order for this variable to operate, the user must define one of the Marquee inputs to provide the BAD PART COUNT signal.

On the transition from the input going from a non-active state to an active state the BAD COUNT variables value will be increased.

### Configuration Options

The amount to increase the value of BAD PART COUNT on each transition is specified on the COUNT/RATE/TAKT/DOWNTIME/OEE CONFIGURATION page. The field SCALE FACTOR and RESULT DIVIDER in the COUNT/RATE PARAMETERS section of this page, allows the user to specify what value to add to the BAD COUNT on each transition of the BAD PART COUNT UP (scale factor) input. Also a RESULT DIVIDER allows the user to only count a single bad count for multiple input transitions of the count input.

COUNT/RATE PARAMETERS				
SCALE FACTOR	RESULT DIVIDER	SAMPLE PERIOD (SEC)	RATE TIME OUT (SEC)	RATE ROUNDING
1	1	2	4	1's ▾

## GOAL

---

GOAL is a set point that is used by the Marquee to calculate other production variables. GOAL is the number of parts, cycles etc. that a given machine is expected to have in a given shift, production run, day etc. The term target is interchangeable with GOAL.

### Configuration Options

The value of GOAL can be set by the IR remote and also on the MESSAGE AND DATA CONFIGURATION page as well as the INPUT CONFIGURATION page. A change in any of these areas will change the value of GOAL.

EXAMPLE: An operator is expected to product 100 parts in a given shift. The user sets the GOAL set point at 100.

## GOAL - COUNT

---

GOAL - COUNT is a calculated variable based on the GOAL set point and the current TOTAL COUNT. This variable can be used to display the number of parts remaining to be complete.

### Configuration Requirements

In order for this variable to operate, the user must define one of the Marquee inputs to provide the PART COUNT signal.

The GOAL set point must also be entered via the IR remote or in the configuration pages.

EXAMPLE: The user wishes to show the operator how many parts are remaining for them to reach their quota. The user would display the variable GOAL - COUNT on the Marquee. The value would start at the GOAL set point and decrease each time a transition occurs on the input that has the PART COUNT UP signal defined.

## % BAD

---

% BAD is a calculated variable based on the TOTAL COUNT and BAD COUNT variables of the Marquee. This variable is used to display the percentage of bad parts to total parts produced. Many times this is considered a measurement of quality.

FORMULA:  $BAD\ COUNT / TOTAL\ COUNT$

**Note:** The input signal PART COUNT DOWN/BAD COUNT UP should not be used if this variable is to be used. Use two inputs PART COUNT UP and BAD PART COUNT.

### Configuration Requirements

In order for this variable to operate, the user must define one of the Marquee inputs to provide the PART COUNT signal and a second input to provide the BAD PART COUNT.

## % COMPLETE

---

% COMPLETE is a calculated variable based on the TOTAL COUNT and GOAL variables of the Marquee. This variable is used to display the percentage of the GOAL that has been completed.

FORMULA: TOTAL COUNT / GOAL

### Configuration Requirements

In order for this variable to operate, the user must define one of the Marquee inputs to provide the PART COUNT and set the GOAL set point with IR remote or on the configuration pages.

## TARGET COUNTER

The TARGET COUNTER variable, also referred to as Takt time or calculated target, is a calculated variable of the Marquee.

TARGET COUNTER gives the user the ability to illustrate to the operator the number of parts, cycles etc. that should have been completed at a point within the shift, day, production run etc. Basically the TARGET COUNTER variable is a counter within the Marquee that increases its value based on time set point. This means that the Marquee increases the value of TARGET COUNTER at a user defined time by a user defined value.

### Configuration Requirements

In order for the TARGET COUNTER variable to operate the user must define both the time period that will be used to increase the value of TARGET COUNTER and the value to increase. This is done on the COUNT/RATE/TAKT/DOWNTIME/OEE CONFIGURATION page of the Marquee.

TAKT TIMER/TARGET COUNTER (OEE PERFORMANCE) CONFIGURATION				
TIME INTERVAL(SEC)	VALUE PER INTERVAL	RESTART AFTER RESET	HOLD TIMER IF IN SETUP	HOLD TIMER IF DOWN
10	1	<input type="checkbox"/>	<input type="checkbox"/>	<input type="checkbox"/>

The TIME INTERVAL is used to specify how often to increase the value of TARGET COUNTER. The VALUE PER INTERVAL field is used to specify the value to add to the TARGET COUNTER variable at the TIME INTERVAL.

**Note:** The input signal HOLD PACE can be used to stop TARGET COUNTER from increasing. This is typically used during break periods such as lunch.

**EXAMPLE:** An operator is expected to produce 10 parts per hour. The user wishes to display to the operator how many parts should have been completed at any giving time during the day. To accomplish this the user uses the TARGET COUNTER. The first step is to determine how long it should take to produce one part (in seconds).

1 hour = 60 minutes = 3600 seconds

3600/ 10 parts per hour = 360

At this point the INTERVAL TIME is set to 360 and the INTERVAL VALUE is set to 1. This causes the TARGET COUNTER variable to increase by a value of 1 every 360 seconds. The TARGET COUNTER variable will continue to increase in value automatically until a reset operation occurs or the PACE HOLD input becomes active.

## % OF TARGET COUNTER

---

% OF TARGET COUNTER is a calculated variable that is based on TARGET COUNTER and TOTAL PART COUNT. This variable is used to display the percentage of the TARGET COUNTER that is completed. This variable can be used to determine if an operation is on track to complete expected parts by the end of the shift, day, production run etc.

FORMULA: TOTAL COUNT / TARGET COUNTER

### Configuration Requirements

In order for this variable to operate, the user must define one of the Marquee inputs to provide the PART COUNT UP signal and TARGET COUNTER needs to be configured.

## HISTORICAL COUNT

---

The HISTORICAL COUNT variable contains the TOTAL COUNT value prior to the last reset operation. In other words, if the user wishes to view the number of parts produced previous shift, day, production run, etc., the HISTORICAL COUNT can be displayed.

### Configuration Requirements

In order for this variable to operate, the user must define one of the Marquee inputs to provide the PART COUNT UP signal.

## DOWNTIME

---

The DOWNTIME variable contains the amount of time that a machine has been down, not running, in setup or in user mode, since the last reset operation. DOWNTIME is increased as long as the MACHINE RUN input signal is not active or if RATE equal 0 and the system is not in SETUP MODE or USER MODE, based on user configuration.

**Note:** If the DISPLAY FORMAT is anything other than HH:MM or HH:MM:SS the Marquee will display the number of seconds the MACHINE RUN input was not active or RATE was equal to 0, based on user configuration.

### Configuration Requirements

The way in which DOWNTIME is calculated is based on the user selection for MACHINE DOWNTIME WILL BE BASED ON field on the COUNT/RATE/TAKT/DOWNTIME/OEE CONFIGURATION page.



Two options are available to determine if the machine is down.

IF MACHINE RUN INPUT IS NOT ON is used when an input to the Marquee will indicate the state of the machine. In order for this operate, the user must define one of the Marquee inputs to provide the MACHINE RUN signal.

IF RATE = 0 is used if the user wishes to monitor the production rate to determine if the machine is down. Please refer to RATE variables to configure how the rate parameters effect this operation.

## RUNTIME

---

The RUNTIME variable contains the amount of time that a machine has run, not down or in setup, since the last reset operation. RUNTIME is increased as long as the machine is not down or in setup mode.

**Note:** If the DISPLAY FORMAT is anything other than HH:MM or HH:MM:SS the Marquee will display the number of seconds the MACHINE RUN input was active.

### Configuration Requirements

If DOWNTIME is based on IF MACHINE RUN INPUT IS NOT ON the user must define one of the Marquee inputs to provide the MACHINE RUN signal. If Downtime is based on IF RATE = 0, the user must configure the RATE parameters.

## SETUP TIME

---

The SETUP TIME variable contains the amount of time that a machine has been in setup mode since the last reset operation. SETUP TIME is increased as long as the machine is in setup mode.

**Note:** If the DISPLAY FORMAT is anything other than HH:MM or HH:MM:SS the Marquee will display the number of seconds the SETUP INPUT input was active.

### Configuration Requirements

In order for SETUP TIME to operate, the user must define one of the Marquee inputs to IN SETUP MODE.

## USER MODE TIME

---

The USER MODE TIME variable contains the amount of time that a machine has been in user mode since the last reset operation. USER MODE TIME is increased as long as the machine is in user mode.

**Note:** If the DISPLAY FORMAT is anything other than HH:MM or HH:MM:SS the Marquee will display the number of seconds the IN USER MODE input was active.

### Configuration Requirements

In order for USER MODE TIME to operate, the user must define one of the Marquee inputs to IN USER MODE.

## HISTORICAL DOWNTIME

---

The HISTORICAL DOWNTIME variable contains the DOWNTIME value prior to the last reset operation. In other words, if the user wishes to view the amount of down time for the previous shift, day, production run, etc., the HISTORICAL DOWNTIME can be displayed.

### Configuration Requirements

In order for this variable to operate, the user must define one of the Marquee inputs to provide the MACHINE RUN signal.

## CURRENT CYCLE TIME

---

CURRENT CYCLE TIME is used to display the time since that last part/count has occurred. The value of CURRENT CYCLE TIME is reset upon the count input going active. After this point CURRENT CYCLE TIME is incremented until the next count input signal is received.

**Note:** If the DISPLAY FORMAT is anything other than HH:MM or HH:MM:SS the Marquee will display the number of seconds since the last count input occurred.

EXAMPLE:

The user wishes to display how much time has elapsed since the last part was produced.

## LAST CYCLE TIME

---

LAST CYCLE TIME is used to display the time that was required to build the last part. On the activation on the count input CURRENT CYCLE TIME is copied into LAST CYCLE TIME and then CURRENT CYCLE TIME is reset.

**Note:** If the DISPLAY FORMAT is anything other than HH:MM or HH:MM:SS the Marquee will display the number of seconds since the last count input occurred.

## SHORTEST CYCLE TIME

---

SHORTEST CYCLE TIME is used to display the shortest time period between two count input activations. On the activation of the count input CURRENT CYCLE TIME is compared to SHORTEST CYCLE TIME. If CURRENT CYCLE TIME is less than SHORTEST CYCLE TIME then CURRENT CYCLE TIME is copied into SHORTEST CYCLE TIME.

**Note:** If the DISPLAY FORMAT is anything other than HH:MM or HH:MM:SS the Marquee will display the number of seconds of the SHORTEST CYCLE TIME.

## LONGEST CYCLE TIME

---

LONGEST CYCLE TIME is used to display the longest time period between two count input activations. On the activation of the count input CURRENT CYCLE TIME is compared to

## Available Production Variables

LONGEST CYCLE TIME. If CURRENT CYCLE TIME is greater than LONGEST CYCLE TIME then CURRENT CYCLE TIME is copied into LONGEST CYCLE TIME.

**Note:** If the DISPLAY FORMAT is anything other than HH:MM or HH:MM:SS the Marquee will display the number of seconds of the LONGEST CYCLE TIME.

## AVERAGE CYCLE TIME

---

AVERAGE CYCLE TIME is used to display the average of the last 25 cycles of the machine.

After each cycle of the machine, the last 25 cycle times are added together and then divided by 25. In the case that 25 cycles have not occurred, only the cycle times for the current number of cycles is used to calculate this variable.

**Note:** If the DISPLAY FORMAT is anything other than HH:MM or HH:MM:SS the Marquee will display the number of seconds of the AVERAGE CYCLE TIME.

## RATE VARIABLES (PER SECOND/MINUTE/HOUR)

The Marquee supports three rate variables for monitoring or displaying current product rate. Rate variables calculate the machine speed or production rate for a given operation. Depending on the application, the user may wish to display or monitor the rate at which parts or product are being produced. At the same time rate can be used to determine if the machine is not running or DOWN. The rate variables are based on the RATE PARAMETERS as defined on the COUNT/RATE/TAKT/DOWNTIME/OEE CONFIGURATION page.

COUNT/RATE PARAMETERS				
SCALE FACTOR	RESULT DIVIDER	SAMPLE PERIOD (SEC)	RATE TIME OUT (SEC)	RATE ROUNDING
1	1	2	4	1's

SAMPLE PERIOD is the time period in seconds that activations of the count input are counted. This period directly relates to the update period for the rate variables. If SAMPLE PERIOD is set at 5 seconds then the Marquee will count pulses for 5 seconds and then calculate the rate and update the display.

**Note:** Accuracy of rate is directly tied to SAMPLE PERIOD. The longer the SAMPLE PERIOD the better the accuracy will be. But also the longer the SAMPLE PERIOD the less often the rate variable will be updated. The best case is that the SAMPLE PERIOD is set so as a minimum of 2 counts will occur during this time period.

RATE TIME OUT is used to determine if the rate of the machine is 0. If no count input is detected for this period the rate will be set to 0 rate. This setting is used for downtime monitoring, if the user selects DOWNTIME to be based off RATE=0.

SCALE FACTOR and RESULT DIVIDER are used to scale the count input so as the user can display such things as feet/minute etc. In most cases both of these parameters will be set to 1. This indicates to the Marquee that 1 count input equals one product, length etc. In some case, for instance feet/minute, a device such as an encoder is used to determine length. If this is the case the RESULT DIVIDER is used to determine the number of counts per foot.

RATE ROUNDING is used to round the rate to 1's, 10's, 100's, etc. This allows the user to display a more stable rate. This is typically used in high speed applications where the lower digits of the rate are not as important.

### EXAMPLE:

A machine is expected to run a product at 100 feet per minute. The count input is connected to an encoder that creates 60 pulse per revolution and 1 revolution is equal to 1 foot.

In this example the user would configure the RESULT DIVIDER to be 60, because the number of counts per foot is 60.

## Takt TIME Elapsed/ Takt TIME Remaining

Takt time is the expected time to complete a product. The Takt timer is used to increment the variable TARGET COUNT. The user configures the Takt TIME parameters on the COUNT/RATE/TAKT/DOWNTIME/OEE CONFIGURATION page.

TAKT TIMER/TARGET COUNTER (OEE PERFORMANCE) CONFIGURATION				
TIME INTERVAL(SEC)	VALUE PER INTERVAL	RESTART AFTER RESET	HOLD TIMER IF IN SETUP	HOLD TIMER IF DOWN
10	1	<input type="checkbox"/>	<input type="checkbox"/>	<input type="checkbox"/>

TIME INTERVAL specifies the Takt Timer preset time period. The Takt timer will start timing from this point until the timer reaches 0. Upon reaching 0 the TARGET COUNT variable is incremented by the value of VALUE PER INTERVAL and the Takt timer restarts.

RESTART AFTER RESET is used to restart the Takt timer at the TIME INTERVAL setpoint after a RESET has occurred. In some cases the user may not want to restart the Takt timer on the start of a shift or day, so this option allows the Takt timer to continue running and not restart after a RESET has occurred.

HOLD TIMER IF IN SETUP is the option that allows the current value of the Takt timer to be unchanged through a SETUP operation. By default the Takt timer will restart at the TIME INTERVAL setpoint on the transition from SETUP to RUN.

HOLD TIMER IF DOWN is the option that allows the current value of the Takt timer to be unchanged through a DOWN state. By default the Takt timer will restart at the TIME INTERVAL setpoint on the transition from DOWN to RUN.

The TARGET COUNTER is also used for establishing MACHINE PERFORMANCE. This variable contains the percentage of parts made to the percentage of part expect (TARGET COUNTER value).

**Note:** If the DISPLAY FORMAT is anything other than HH:MM or HH:MM:SS the Marquee will display the number of seconds either remaining or elapsed of the Takt Timer.

## QUALITY

---

QUALITY is a calculated variable based on the TOTAL COUNT and BAD COUNT variables of the Marquee. This variable is used to display the percentage of good parts to total parts

FORMULA:  $(\text{TOTAL COUNT} - \text{BAD COUNT}) / \text{TOTAL COUNT}$

**Note:** The input signal PART COUNT DOWN/BAD COUNT UP should not be used if this variable is to be used. Use two inputs PART COUNT UP and BAD PART COUNT.

### Configuration Requirements

In order for this variable to operate, the user must define one of the Marquee inputs to provide the PART COUNT signal and a second input to provide the BAD PART COUNT.

## MACHINE AVAILABILITY

---

MACHINE AVAILABILITY is a calculated variable of the Marquee. MACHINE AVAILABILITY is the percentage of time since last reset that the machine has been in RUN mode. For scheduled breaks the user may choose not to calculate downtime. This configuration is down on the BREAKS/SCHEDULED DOWN TIMES page.

FORMULA

$\text{MACHINE AVAILABILITY} = \text{RUN TIME} / \text{TOTAL TIME}$

where  $\text{TOTAL TIME} = \text{RUN TIME} + \text{DOWN TIME} + \text{SETUP TIME} + \text{USER MODE TIME}$

## MACHINE PERFORMANCE

---

MACHINE PERFORMANCE is a calculated variable of the Marquee. MACHINE PERFORMANCE is the percentage of parts made to parts expected. This establishes a performance index based on production output compared to actual production.

FORMULA

$\text{MACHINE PERFORMANCE} = \text{TOTAL COUNT} / \text{TARGET COUNTER}$

## OEE

---

OEE, which stands for overall equipment effectiveness, is a calculated variable of the Marquee. OEE takes into account three aspects of a machine's effectiveness, performance, availability and quality. By looking at these variables an overall effectiveness of the machine can be observed.

FORMULA

$\text{OEE} = \text{MACHINE PERFORMANCE} \times \text{MACHINE AVAILABILITY} \times \text{QUALITY}$

## MACHINE STATE

---

The MACHINE STATE variable allows the user to display the current state of the machine RUN, DOWN, SETUP or USER. The user can configure the text or value to be displayed by this variable on the STATE TEXT AND OVERRIDE MESSAGES page.

STATE TEXT	
MACHINE STATE	DISPALYED TEXT
RUNNING	RUN
DOWN	DOWN
IN SETUP	SETUP
USER	STANDBY

## MODBUS/TCP reg. VARIABLES

---

The next 5 variables are Modbus/TCP variables. These variables allow a third party software or hardware product, like an HMI, to write values for displaying on the Marquee. These variables have no effect on the operation of the Marquee but are implemented in order to allow the user to display values from another device/system onto the Marquee. Please refer to the Modbus/TCP section for a detail operation of the Modbus/TCP implementation of the Marquee.

5 Modbus registers are defined for the purpose of displaying values from third party devices. Each register is a 32 bit long integer register.

Modbus Registers are 40131,40133,40135,40137 and 40139.

Example: The user has a third party device that communicates as a Modbus/TCP master/client and this device connects to a temperature probe within an oven. The user wants to display the temperature on the Marquee. The user sets the device to write the temperature value to register 40131 at the IP address of the Marquee. The user then sets the Marquee to display the MODBUS/TCP reg. 40131.

## TIME

---

The TIME variable contains the current time from the Marquee's built-in real time clock.

**Note:** Depending on the display format the TIME variable will display HH:MM:SS or just HH:MM.

## DATE

---

The DATE variable contains the current date from the Marquee's built-in real time clock.

**Note:** Depending on the display format the DATE variable will display MM/DD/YY or just MM/DD.

## Available Production Variables

## —Chapter 6—

# Web Data Configuration

---

This chapter will discuss configuring the WEB DATA operations of the MARQUEE.

WEB DATA is DataVisor Marquee's method of allowing the user to access data within the MARQUEE in order to present this data to other Windows applications such as spreadsheets and development tools. This chapter uses Microsoft Excel 2003 to demonstrate this operation. Other packages are available that also support the functionality required to access data from the Marquee. As long as the product that is being used has support for WEB DATA QUERY, it may be used in the same manner described within this chapter.

## Configuring The WEB DATA Variables

---

From the SETUP MENU the user selects CONFIGURE WEB DATA.

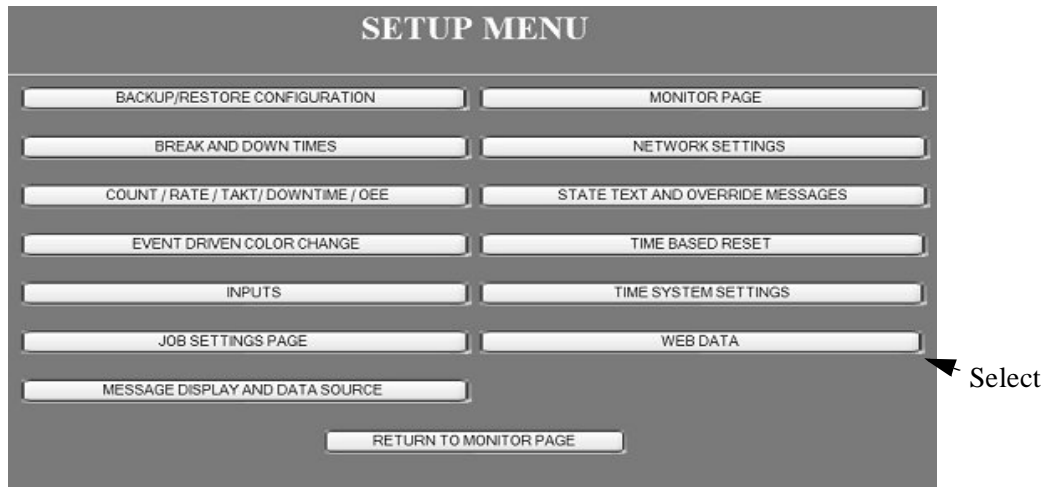

## Web Data Configuration

This opens the WEB DATA CONFIGURATION page. This page allows the user to specify the data that will be available to EXCEL. Along with the data the user can specify a description that will accompany the data. This description can be used to identify where the data is coming from such as LINE #1, MACHINE #6, etc. The data selection boxes allow the user to configure up to 10 values that will be sent to EXCEL. If not all 10 values are needed, select NONE as the data source for any fields and that field will not be sent.

The screenshot shows a web interface titled "WEB DATA CONFIGURATION". It features a table with 10 columns for data selection. The first column is labeled "DESCRIPTION" and contains "Line 1". The other columns are labeled "DATA 1" through "DATA 10". Each data column contains a dropdown menu with a specific data source selected. Below the table are two buttons: "Apply Changes" and "RETURN TO SETUP MENU".

WEB DATA CONFIGURATION				
DESCRIPTION	DATA 1	DATA 2	DATA 3	DATA 4
Line 1	TOTAL COUNT	GOAL	%COMPLETE	DOWNTIME
	DATA 5	DATA 6	DATA 7	DATA 8
	PACE	% BAD	% OF PACE	SHORTEST CYCLE TIME
	DATA 9	DATA 10		
	TIME	DATE		

Apply Changes

RETURN TO SETUP MENU

Upon selecting the data to send the user must click the Apply Changes button in order for the changes to take affect.

## Setting-up Excel For WEB DATA

Once the WEB DATA configuration has been made in the MARQUEE, the next step is to configure EXCEL to get the data from the MARQUEE. The following is a step by step procedure to setup the connection between EXCEL and the MARQUEE.

### STEP 1:

Open EXCEL on the PC that has an Ethernet connection to the MARQUEE and start a new WORKBOOK.

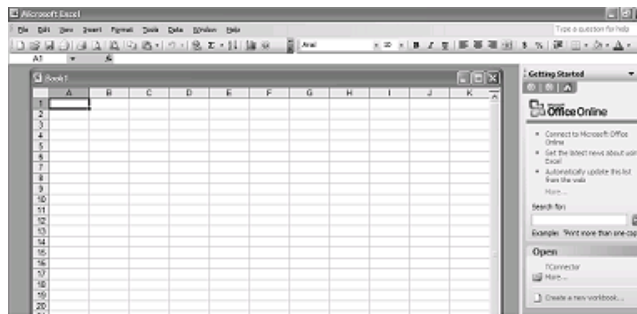

### STEP 2:

Under the DATA menu select "Import External Data" followed by "New WEB Query".

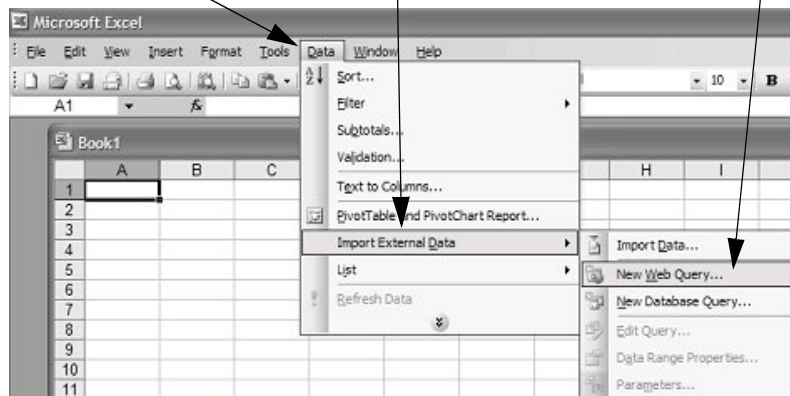

**STEP 3:**

The WEB Query dialog box will open. The user will now enter the IP address of the MARQUEE followed by “/webdata”.

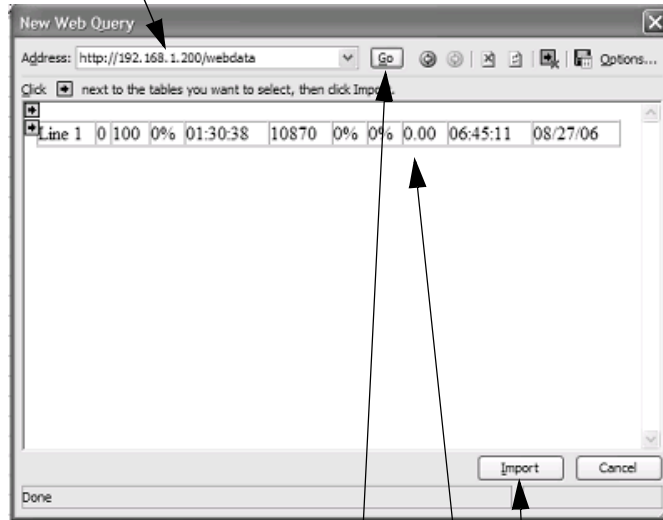

After the IP has been entered click on the GO button. This will cause EXCEL to connect to the WEB server that is built into the Marquee. The configured data and description should now be displayed. Click the Import Button to start the Import operation.

**Note:** If EXCEL is unable to connect to the MARQUEE, verify that the MARQUEE is accessible via your WEB Browser. Please refer to the ETHERNET CONNECTION chapter if you are unable to connect to the MARQUEE via Ethernet.

**STEP 4:**

After the Import button is pressed the Import Data dialog box will appear. Here the user can specify where the data will be placed on the worksheet. Clicking the Properties button will open the properties dialog box for this data import.

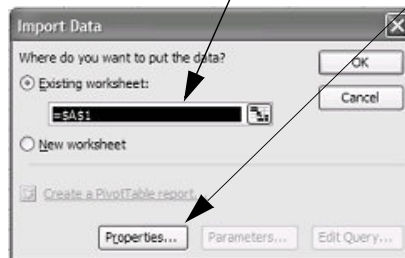

**STEP 5:**

The properties dialog box allows the user to setup the automatic data refresh. Auto refresh allows the data on the worksheet to be updated on a periodic basis without user intervention.

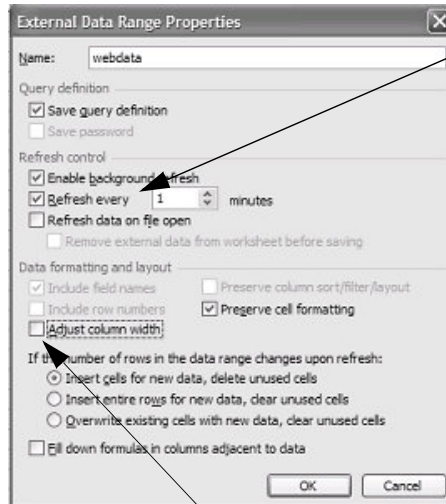

Another property that should be set is the “Adjust Column Width”. It is highly recommended to disable this function. If this function is left enabled the column width will be determined by the data being read. This is not desired in most cases when dealing with active data. After setting the properties, click the OK button. Then click the OK button on the WEB Query dialog box.

**STEP 6:**

At this point EXCEL will connect to the MARQUEE and gather the data and fill in the spreadsheet.

	A	B	C	D	E	F	G	H	I	J	K
1											
2	Line 1		0	100	0%	1:32:13	11060	0%	0%	0	6:46:46 8/27/2006

**STEP 7:**

At this point no further configuration is required. But in many cases the user will wish to add a column description for each data field.

	A	B	C	D	E	F	G	H	I	J	K
1	DESCRIPTION	COUNT	GOAL	% COMPLETE	DOWNTIME	PACE	% OF PACE	% BAD	BAD PARTS	TIME	DATE
2	Line 1		0	100	0%	1:34:13	11300	0%	0%	0	6:48:46 8/27/2006

### STEP 8:

The user has now finished the configuration. Follow these steps for each MAQUEE in order to display data from each MARQUEE that is in use.

## Modbus/TCP Server

---

This chapter will discuss the implementation of the Modbus/TCP server. Modbus/TCP is an open communication method of sending and receiving data from devices on an ethernet network. Modbus/TCP uses standard TCP/IP communications technique to encapsulate modbus commands within a TCP/IP telegram. This communication technic has become widely excepted and is currently implemented in thousands of products worldwide.

The DataVisor PM series of Marquees utilizes Modbus/TCP as a method of allowing third party products such as HMI, HMI software, scada system and a multitude of other systems to both read variables from the Marquee and write setup and configuration data to the Marquee.

The Marquee is designed to be a Modbus/TCP server or slave device. This means that if the user wishes to connect a third party device to the Marquee it must be a a Modbus/TCP client or master device.

In this chapter the user will find the relevant information to connect the Marquee to a Modbus/TCP client and the Modbus memory map of the variables of the Marquee.

### Modbus/TCP Client Setup

---

The DataVisor Marquee is setup as a Modbus/TCP server. The Modbus/TCP client must be configured as described in the following table in order to communicate to the Marquee.

**Table 1—Modbus/TCP Client Configuration**

Option	Setting
RTU/ASCII	RTU
MODBUS ADDRESS	1
IP ADDRESS	IP address of Marquee
Data Type	32 bit integer or Long Integer

## Modbus/TCP Memory Map Variables

All production variables within the Marquee can be read over Modbus/TCP. The following table shows the variable and its corresponding Modbus address. Use this address in the client/master system to access these variable. All variable are defined as 32 bit long integers.

**Table 2—Modbus/TCP Variable Memory Map**

Variable	Access	Register	Comment
TOTAL COUNT	READ	40001	
BAD COUNT	READ	40003	
GOAL	BOTH	40005	
GOAL-COUNT	READ	40007	
% BAD	READ	40009	
% COMPLETE	READ	40011	
TARGET COUNTER	READ	40013	
% OF TARGET COUNTER	READ	40015	
HISTORICAL COUNT	READ	40017	
DOWNTIME	READ	40019	IN SECONDS
RUNTIME	READ	40021	IN SECONDS
SETUP TIME	READ	40023	IN SECONDS
USER MODE TIME	READ	40025	IN SECONDS
HISTORICAL DOWNTIME	READ	40027	IN SECONDS
CURRENT CYCLE TIME	READ	40029	IN SECONDS
LAST CYCLE TIME	READ	40031	IN SECONDS
SHORTEST CYCLE TIME	READ	40033	IN SECONDS
LONGEST CYCLE TIME	READ	40035	IN SECONDS
AVERAGE CYCLE TIME	READ	40037	IN SECONDS
RATE PER SECOND	READ	40039	
RATE PER MINUTE	READ	40041	
RATE PER HOUR	READ	40043	
Takt TIME ELAPSED	READ	40045	IN SECONDS
Takt TIME REMAINING	READ	40047	IN SECONDS
QUALITY	READ	40049	
MACHINE AVAILABILITY	READ	40051	
MACHINE PERFORMANCE	READ	40053	
OEE	READ	40055	

**Table 2—Modbus/TCP Variable Memory Map**

MACHINE STATE	READ	40057	1= RUN 2= DOWN 3 = SETUP 4 = USER
Modbus/TCP reg. 40131	WRITE	40131	
Modbus/TCP reg. 40133	WRITE	40133	
Modbus/TCP reg. 40135	WRITE	40135	
Modbus/TCP reg. 40137	WRITE	40137	
Modbus/TCP reg. 40139	WRITE	40139	

## Modbus/TCP Memory Map Configuration and Control

---

Along with allowing access to the variables of the Marquee, the Data Visor Marquee allows the user to control certain aspects of the Marquee's operation and allows the user to change configuration options via Modbus/TCP. The following tables shows a listing of Modbus registers that can be used to control and change configurations on the Marquee.

**Table 3—Modbus/TCP Control**

Modbus Register	Marquee Operation
40100 bit 1	Puts Marquee in Setup Mode
40100 bit 2	Puts Marquee in Run Mode
40100 bit 3	Puts Marquee in User Mode
40100 bit 4	On transition from OFF to ON increments BAD PART COUNTER
40100 bit 5	On transition from OFF to ON Resets Marquee
40100 bit 6	Turns on Takt Hold stopping Takt Timer
40100 bit 7	On transition from OFF to ON cause count to be decremented PART COUNT DOWN
40100 bit 8	On transition from OFF to ON cause count to be decremented PART COUNT DOWN and BAD PART COUNTER to be Incremented
40100 bit 9	Causes Override Message #1 to be Displayed
40100 bit 10	Causes Override Message #2 to be Displayed

**Table 4—Modbus/TCP Configuration**

Modbus/TCP Register	Marquee Configuration
40103	Sets the Count Scale Factor
40105	Sets the Count Result Divider
40107	Sets the Rate Sample Period
40109	Sets the Rate Time-out Period
40111	Sets Takt Timer Time period
40113	Sets Target Counter Increment Value
40115	Event Based color change setpoint index 1 setpoint 1
40117	Event Based color change setpoint index 1 setpoint 2
40119	Event Based color change setpoint index 2 setpoint 1
40121	Event Based color change setpoint index 2 setpoint 2
40123	Event Based color change setpoint index 3 setpoint 1
40125	Event Based color change setpoint index 3 setpoint 2
40127	Event Based color change setpoint index 4 setpoint 1
40129	Event Based color change setpoint index 4 setpoint 2

## —Chapter 8—

### Mounting Instructions

This chapter will discuss the mounting possibilities available. Mounting hardware is included with each Marquee.

#### Mounting Hardware Included



Mount Attachment  
Nut 5/16 Qty 4



Slide-In Mount Attachment  
Bolt 5/16 (custom) Qty 4



Mount Interconnect  
Nut 6mm Qty 4



Mount Interconnect  
Bolt 6mm Qty 4

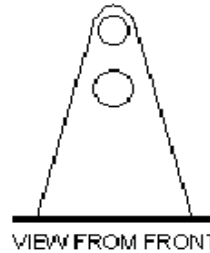

VIEW FROM FRONT

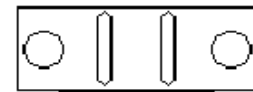

VIEW FROM BOTTOM

Hanger/Stand Mounting Bracket Qty 2

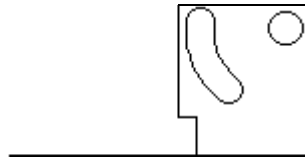

View from Front



View From Bottom

Swivel Mount Bracket

## Installing Mount Attachment Bolts

---

Prior to mounting the Marquee the mount attachment bolts must be installed.

**WARNING**—In order to install the mount attachment bolts the end cap on the left (when looking at front of Marquee) must be removed.

**WARNING**—DO NOT REMOVE THE END CAP ON THE RIGHT HAND SIDE!

1. Remove 4 outside screws holding END CAP. (A)
2. Remove END CAP.(B)
3. Slide 2 to 4 mount bolts into groove. (C)
4. Replace END CAP.
5. Replace 4 END CAP screws.

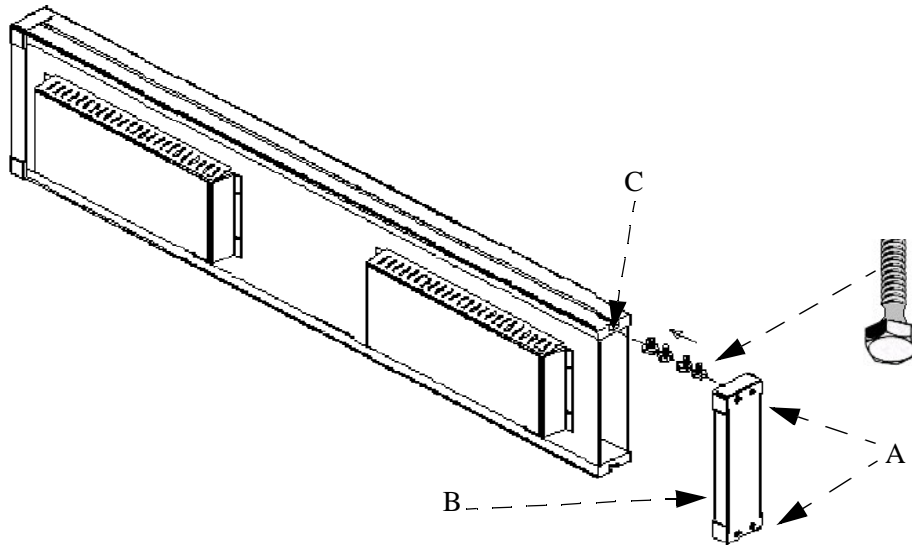

Figure 1—Installing Mount Bolts

**Note:** The number of bolts will be determined by desired mounting method.

**Note:** Bolts may be installed in top slot or bottom depending on desired mounting method.

## Mounting Method Samples

This section illustrates a few of the methods of mounting the Marquee. By no means are these the only ways to mount the Marquee but are examples of how some customers have mounted the Marquee.

### Chain Mount

Marquee mounting components needed:

- 4 mount attachment bolts
- 4 mount attachment nuts
- 2 hanger mounts

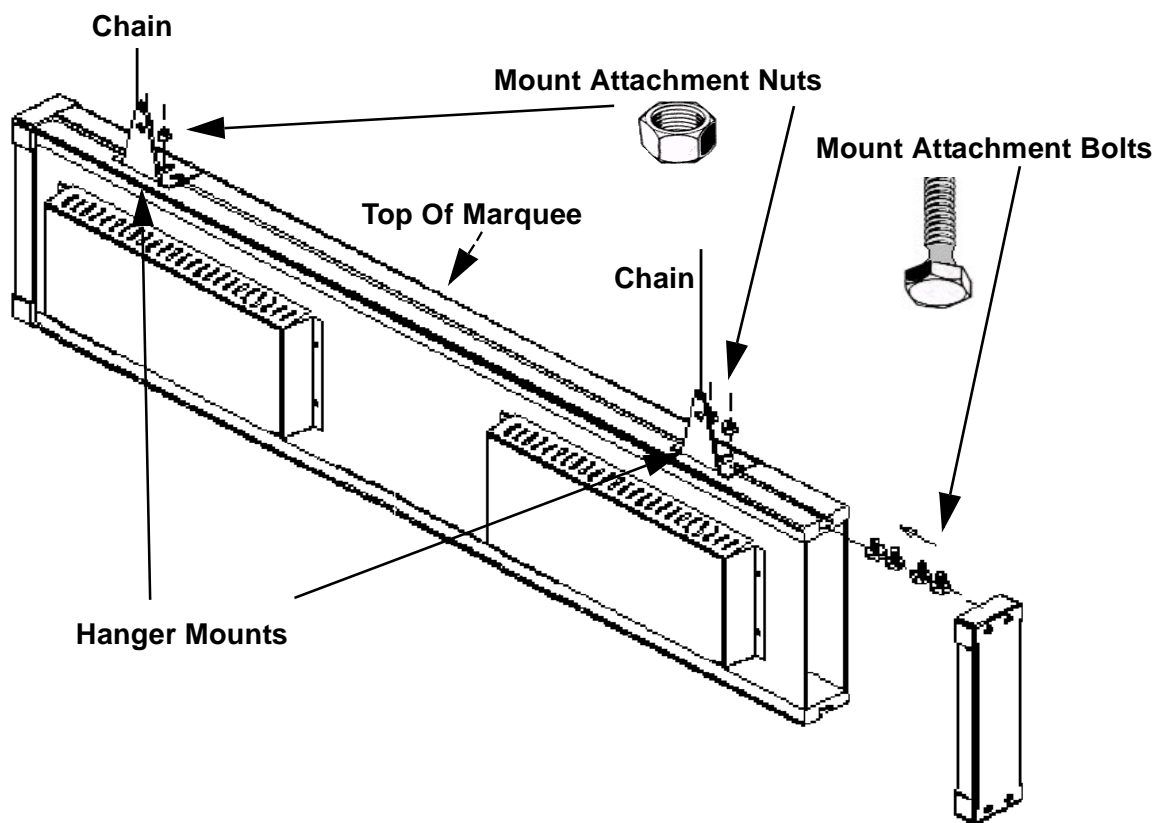

Figure 2—Chain Mount Example

## Wall Mount With Swivel

Marquee mounting components needed:

- 4 mount attachment bolts
- 4 mount attachment nuts
- 2 hanger mounts
- 2 swivel mounts
- 4 mount interconnect bolts
- 4 mount interconnect nuts

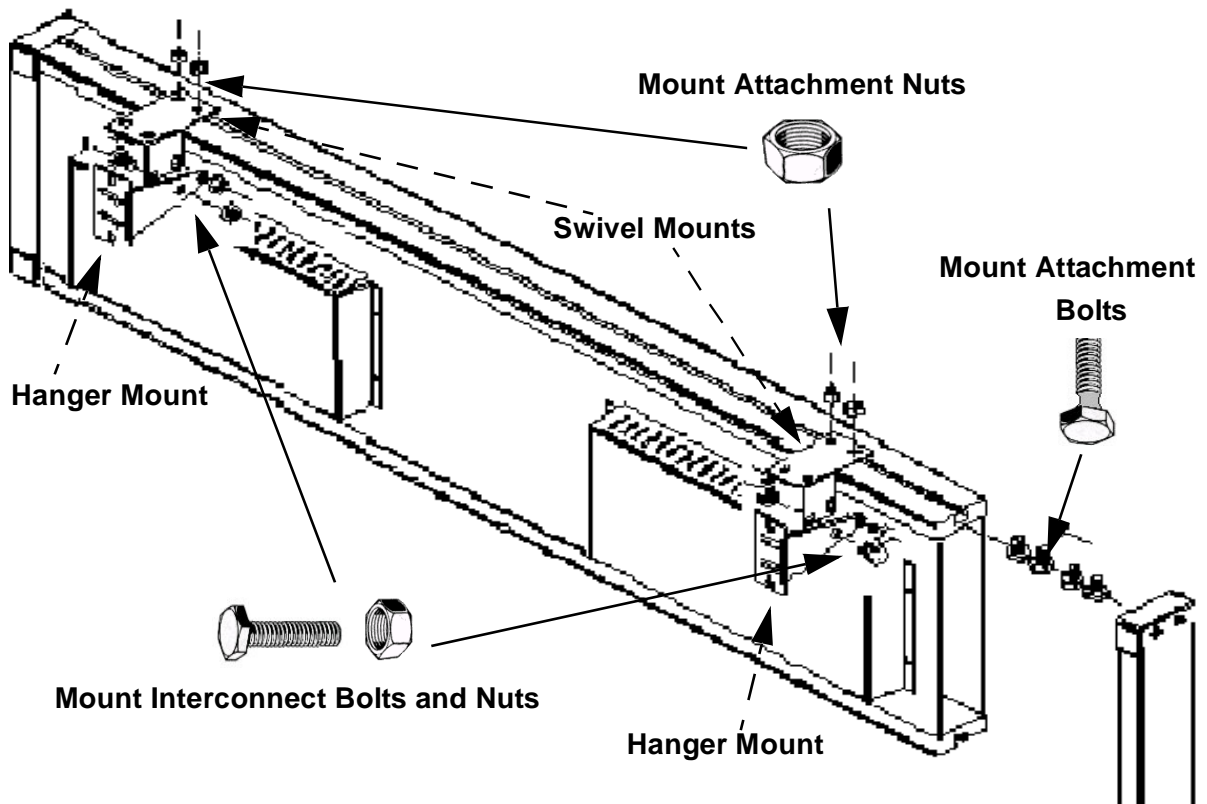

Figure 3—Wall Mount

**Bottom Mount (8020 Front Mount)**

Marquee mounting components needed:

- 4 mount attachment bolts
- 4 mount attachment nuts
- 2 hanger mounts

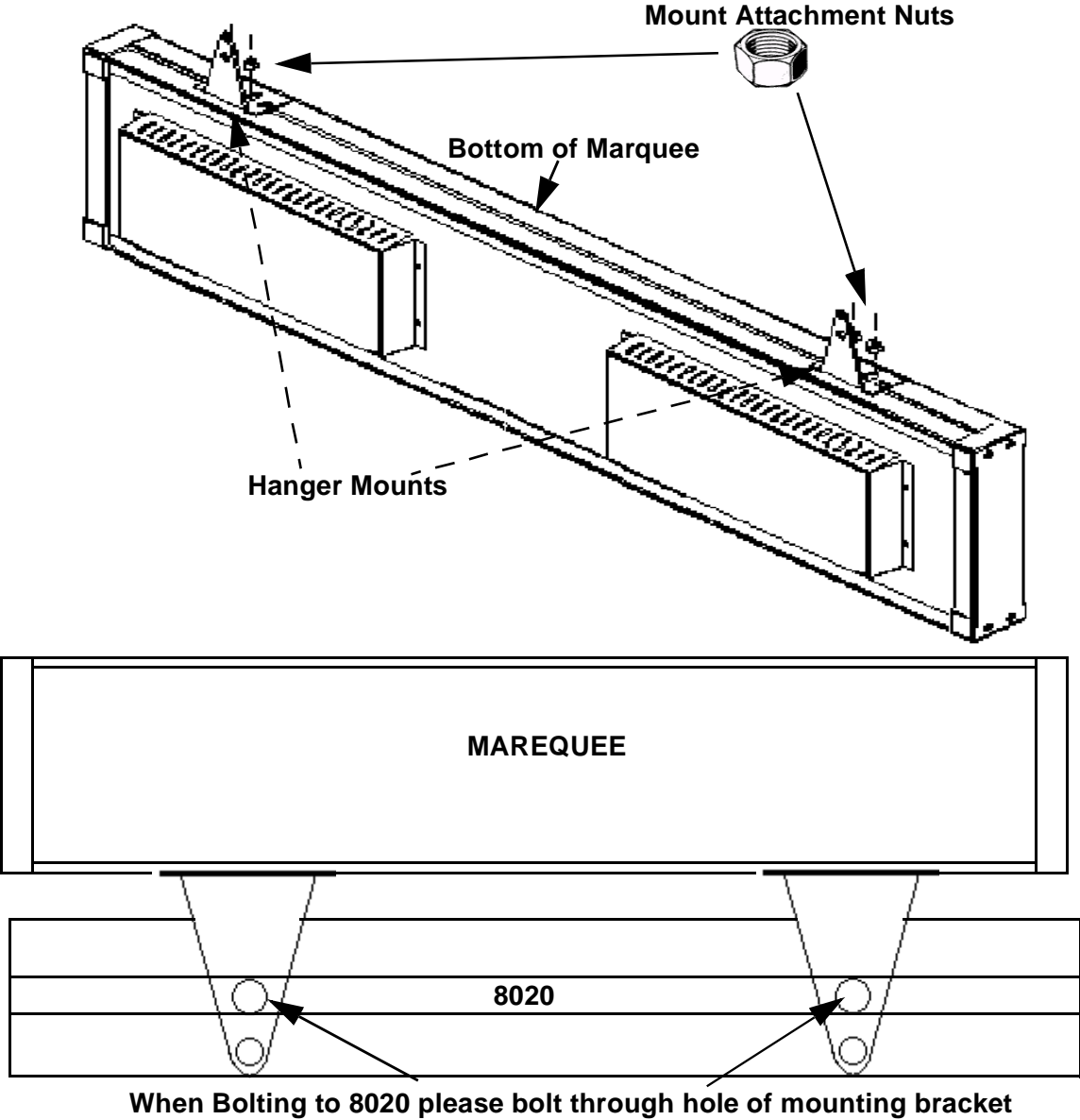

Figure 4—Bottom Mount

### Bottom Mount (8020 top mount)

Marquee mounting components needed:

- 4 mount attachment bolts
- 4 mount attachment nuts
- 2 Swivel Mounts

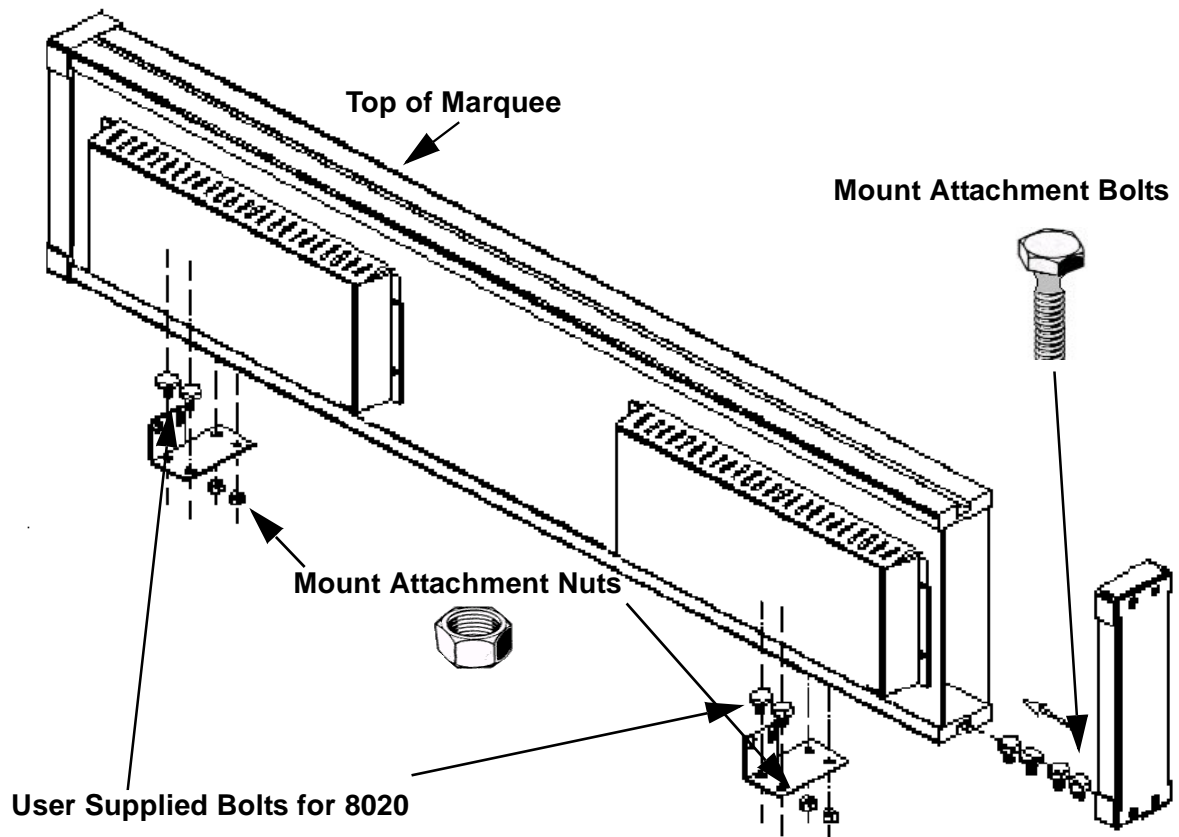

Figure 5—Bottom Mount