

Operation Manual

Model Number: MM-0XXX-T

V2.1

Copyright © 2006 DataVisor Marquees Inc.

Using The IR Remote	5
Key Usage Of IR Remote	6
The IR Menus Of The Marquee	7
Programming With The IR Remote	8
Entering Into Program Mode	8
Maneuvering Through Setup Menus	9
Setting IP Address	10
Setting SubNet Mask	11
Setting Default Gateway	12
Setting Time	13
Setting Date	14
Making The Ethernet Connection	15
Quick Setup	16
Required Equipment	16
Steps To Connect The Marquee Via Ethernet	16
Detailed Ethernet Setup	18
Configuring the PC	18
Using IPCONFIG To Verify Ethernet Settings	22
Connecting The PC To The Marquee	24
Verifying Ethernet Communications	26
Connecting To the Marquee's WEB Server	29
Marquee WEB Pages	33
MAIN PAGE	33
Access Configuration Pages	34
SETUP MENU	35
DISPLAY CONFIGURATION	36
NETWORK CONFIGURATION	38
TIME SETTINGS PAGE	40
BACKUP AND RESTORE PAGE	42
UDP MESSAGING	43
WHAT IS UDP?	43
HOW IS UDP IMPLEMENTED IN THE MARQUEE?	43
FORMATING MESSAGE	44
DISPLAY METHOD MODIFIERS	45
SPECIAL MODIFIERS	47
Mounting Instructions	49
Mounting Hardware Included	49
Installing Mount Attachment Bolts	50
Mounting Method Examples	51

—Chapter 1—

Using The IR Remote

This chapter will discuss the use of the IR remote. The remote is used to initially set the Network Parameters, Time and Date. It can also be used during operation to allow for resetting of process variables.

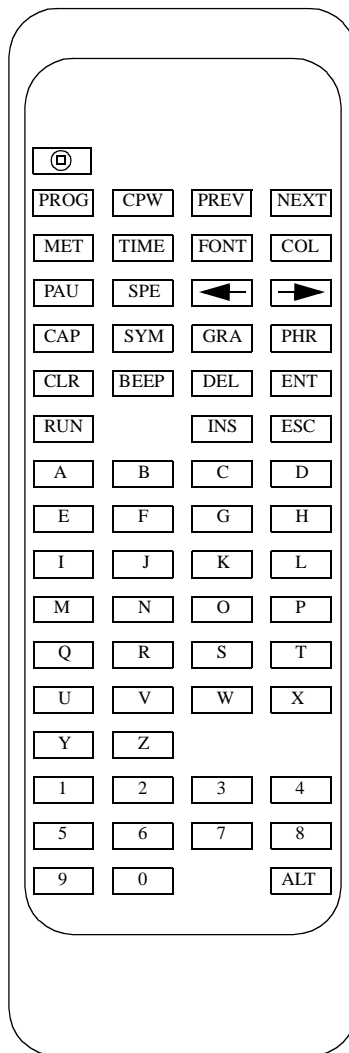

Key Usage Of IR Remote

There are many keys that are not currently used for the operation of the Marquee display. The following lists the keys that have operation capability with the marquee.

KEY	USAGE
PROG	Enter Program Mode
PREV	Go To Previous Program Screen
NEXT	Go To Next Program Screen
←	Move Cursor To Left
→	Move Cursor To Right
RUN	Return to Operating Mode
Y	Used For Conformation Of Change
N	Used for Rejection Of Change
0-9	Numeric Keys For Data Entry

Table 1—IR Remote Key Usage

The IR Menus Of The Marquee

The following are the menus that can be accessed via the IR remote. These menus allow the user to configure the basic settings of the Marquee display.

Menu	Usage
<div style="border: 1px solid black; padding: 5px; text-align: center;"> IP ADDRESS 192.168.1.200 </div>	Allows the user to set the Ethernet IP address for the built in ethernet port of the Marquee.
<div style="border: 1px solid black; padding: 5px; text-align: center;"> NET MASK 255.255.255.000 </div>	Allows the user to set the Ethernet SUB NET MASK for the built in Ethernet port of the Marquee.
<div style="border: 1px solid black; padding: 5px; text-align: center;"> SET GATEWAY 000.000.000.000 </div>	Allows the user to set the Ethernet DEFAULT GATEWAY for the built in Ethernet port of the Marquee.
<div style="border: 1px solid black; padding: 5px; text-align: center;"> SET TIME 02:47:37 </div>	Allows the user to set the TIME for the built in real time clock of the Marquee.
<div style="border: 1px solid black; padding: 5px; text-align: center;"> SET DATE 06/10/06 </div>	Allows the user to set the DATE for the built in real time clock of the Marquee.

Table 2—Marquee Configuration Menus

Programming With The IR Remote

The following section will describe the steps that are taking in order to enter program mode and accessing the Marquee setup menus. In this section the user will be instructed on how to accomplish the following tasks.

- Set the Ethernet parameters of the Marquee
- Set the Time and Date on the Marquee display

Entering Into Program Mode

In order to access the setup menus the user must put the Marquee into program mode. This is as simple as pressing the PROG key on the IR remote.

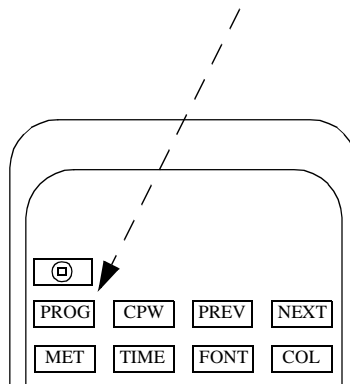

The follow message will be displayed on the Marquee.

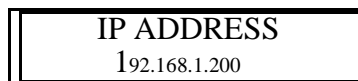

Note: The user should be within 20 Ft of the Marquee in order for IR operations!

Maneuvering Through Setup Menus

Once in program mode, the user uses the PREV and NEXT keys to scroll through the setup menus.

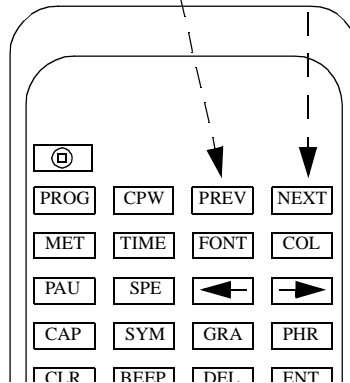

By using these keys the user can select the menu item that is desired and take appropriate action. The NEXT key takes the user to the next menu and the PREV key goes back to the previous menu. If the user is on the last menu and presses the NEXT key the first menu item will be displayed. If the user is on the first menu item and presses the PREV key the last menu item will be displayed.

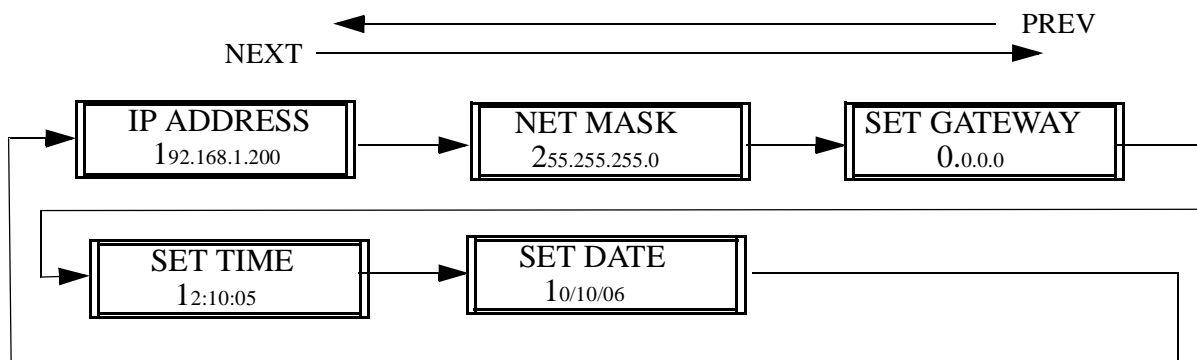

Setting IP Address

The user can set the Ethernet IP address of the built in Ethernet port via the IR remote. Follow these steps to accomplish this task.

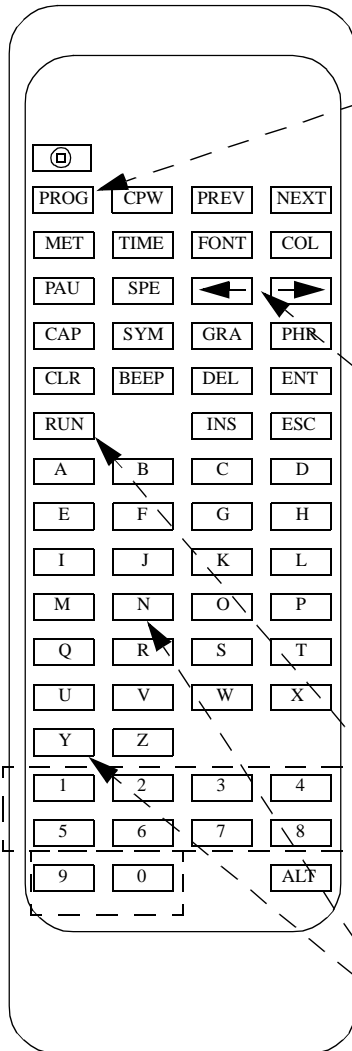

1. Press the PROG key to put Marquee into program mode.

2. The Following message will appear on the Marquee.

IP ADDRESS
192.168.1.200

3. The user should notice that the first digit within the IP address is larger than the reset. This indicates the cursor position.

4. The cursor position can be moved by pressing the → or the ← key of the remote. As you move the cursor the enlarged value will move across the Marquee to indicate current cursor position.

Example: 192.168.1.200 Press →
 192.168.1.200 Press ←
 192.168.1.200

5. Pressing any of the numeric keys will change the value of the current position to that value and move the cursor position to the right.

6. Once the proper IP address is displayed press the RUN key. The confirmation message will be displayed.

ACCEPT NEW IP
PRESS Y FOR YES

7. At this point pressing the Y key will change the Marquee's IP address and return the Marquee to operating mode.
 If the N key is pressed then the IP address will not be changed and the Marquee will return to operating mode.

Setting SubNet Mask

The user can set the Ethernet SubNet Mask of the built in Ethernet port via the IR remote. Follow these steps to accomplish this task.

1. Press the PROG key to put Marquee into program mode.
2. The Following message will appear on the Marquee.

IP ADDRESS
192.168.1.200
3. Press the NEXT key on the remote to go to the NET MASK menu item. The follow will be displayed.

NET MASK
255.255.255.0
4. The user should notice that the first digit within the mask is larger than the rest. This indicates the cursor position.
5. The cursor position can be moved by pressing the → or the ← key of the remote. As you move the cursor the enlarged value will move across the Marquee to indicate current cursor position.

Example: 255.255.255.0 Press →

255.255.255.0 Press ←

255.255.255.0
6. Pressing any of the numeric keys will change the value of the current position to that value and move the cursor position to the right.
7. Once the proper SubNet Mask is displayed press the RUN key. The confirmation message will be displayed.

ACCEPT NEW IP
PRESS Y FOR YES
8. At this point pressing the Y key will change the Marquees Subnet Mask and return the Marquee to operating mode. If the N key is pressed then the Subnet Mask will not be changed and the Marquee will return to operating mode.

Setting Default Gateway

The user can set the Ethernet Default Gateway of the built in Ethernet port via the IR remote. Follow these steps to accomplish this task.

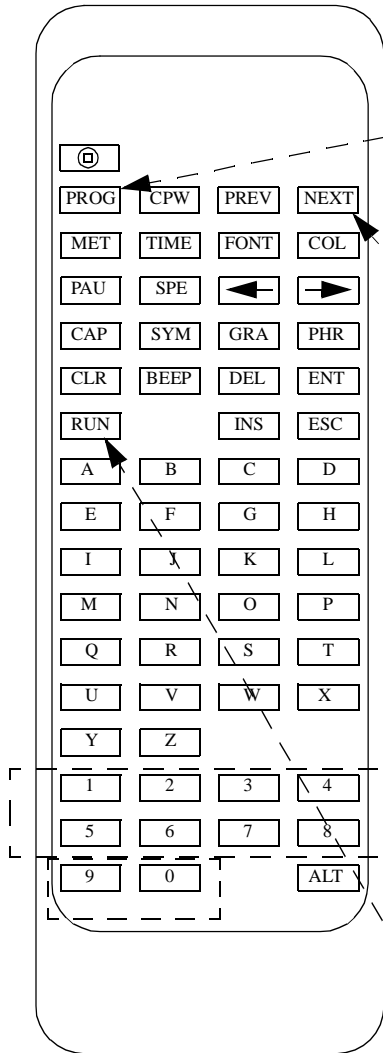

1. Press the PROG key to put Marquee into program mode.

2. The Following message will appear on the Marquee.

```

IP ADDRESS
192.168.1.200
    
```

3. Press the NEXT key two times on the remote to go to the GATEWAY menu item. The follow will be displayed.

```

SET GATEWAY
 0.0.0.0
    
```

4. The user should notice that the first digit within the gateway is larger than the rest. This indicates the cursor position.

5. The cursor position can be moved by pressing the \rightarrow or the \leftarrow key of the remote. As you move the cursor the enlarged value will move across the Marquee to indicate current cursor position.

```

Example: 255.255.255.0 Press  $\rightarrow$ 
          255.255.255.0 Press  $\leftarrow$ 
          255.255.255.0
    
```

6. Pressing any of the numeric keys will change the value of the current position to that value and move the cursor position to the right.

7. Once the proper GATEWAY is displayed press the RUN key. The confirmation message will be displayed.

```

ACCEPT NEW IP
PRESS Y FOR YES
    
```

8. At this point pressing the Y key will change the Marquees Gateway and return the Marquee to operating mode. If the N key is pressed then the Gateway will not be changed and the Marquee will return to operating mode.

Setting Time

The user can set the time of the built in real time clock via the IR remote. Follow these steps to accomplish this task.

The diagram shows an IR remote control with various function keys. A dashed box highlights the numeric keypad (0-9) and the 'ALT' key. Arrows point from the steps to specific keys on the remote and to the callout boxes.

1. Press the PROG key to put Marquee into program mode.
2. The Following message will appear on the Marquee.

IP ADDRESS
192.168.1.200
3. Press the NEXT key three times on the remote to go to the SET TIME menu item. The follow will be displayed.

SET TIME
12:10:05
4. The user should notice that the first digit within the time is larger than the rest. This indicates the cursor position.
5. The cursor position can be moved by pressing the \rightarrow or the \leftarrow key of the remote. As you move the cursor the enlarged value will move across the Marquee to indicate current cursor position.

Example: 12:10:05 Press \rightarrow

12:10:05 Press \leftarrow

12:10:05
6. Pressing any of the numeric keys will change the value of the current position to that value and move the cursor position to the right.
7. Once the proper Time is displayed press the RUN key which set the new time and put the Marquee into operating mode.

Setting Date

The user can set the date of the built in real time clock via the IR remote. Follow these steps to accomplish this task.

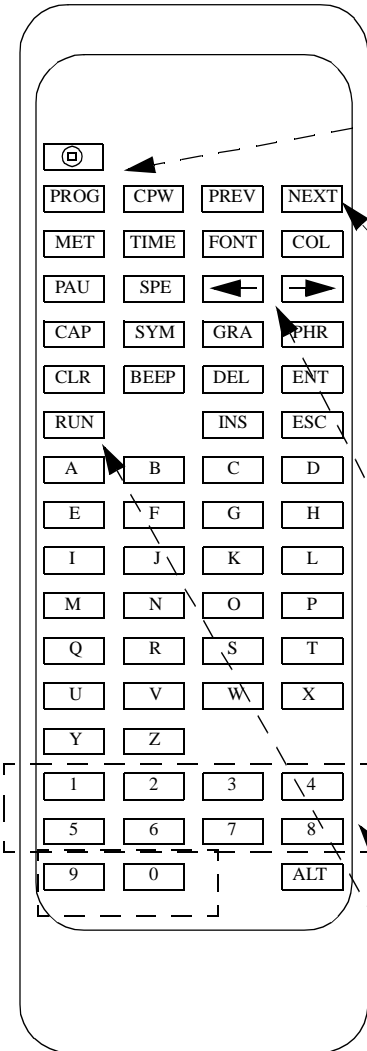

1. Press the PROG key to put Marquee into program mode.

2. The Following message will appear on the Marquee.

IP ADDRESS
192.168.1.200

3. Press the NEXT key four times on the remote to go to the SET TIME menu item. The follow will be displayed.

SET DATE
10/10/06

4. The user should notice that the first digit within the date is larger than the rest. This indicates the cursor position.

5. The cursor position can be moved by pressing the **→** or the **←** key of the remote. As you move the cursor the enlarged value will move across the Marquee to indicate current cursor position.

Example: 10/10/06 Press **→**
 10/10/06 Press **←**
 10/10/06

6. Pressing any of the numeric keys will change the value of the current position to that value and move the cursor position to the right.

7. Once the proper Time is displayed press the RUN key which set the new date and put the Marquee into operating mode.

Making The Ethernet Connection

This chapter describes the steps that are taken in order to connect the Marquee to an ethernet network or configuration PC to allow the configuration of the Marquee.

In most cases, the first step in configuring the Marquee is physically connecting the Marquee to what is known as a configuration PC. A configuration PC can be a laptop or desk-top PC that is equipped with an ethernet port and has WEB browser software installed. There are many different WEB browsers available on the market today. Please refer to the documentation for the WEB browser that is being used, if it is unclear what is needed to be accomplished.

The Marquee can be connected directly to a PC's ethernet port or connected to the facility network. It is recommended the first time a user connects directly to the Marquee and does not connect to the facility network. By connecting directly, the user has more control over the ethernet network settings and the need to consult with the IT department or network administrator of the facility is not required.

Note: Prior to connecting to the facility network, it is highly recommended to consult the facility IT department or the network administrator of the facility.

Quick Setup

This section is designed for the user who is familiar with connecting devices via ethernet. This section assumes a direct connection between the ethernet port of a PC and the Ethernet port of the Marquee.

If the user is not familiar with connecting ethernet devices or configuring ethernet Parameters of the PC it is highly recommended to go to the section *Detailed Ethernet Setup* section.

Required Equipment

- DataVisor Marquee
 - PC with Ethernet port and a Web browser installed
- Note:** The user must have administrator rights on the PC
- An Ethernet cross cable or a switch with an Ethernet patch cable.

Steps To Connect The Marquee Via Ethernet

These steps use the factory default ethernet parameters that are set in the Marquee.

- IP Address 192.168.1.200
- Subnet Mask 255.255.255.0

1. Connect a ethernet cross-over cable between the PC and the Marquee

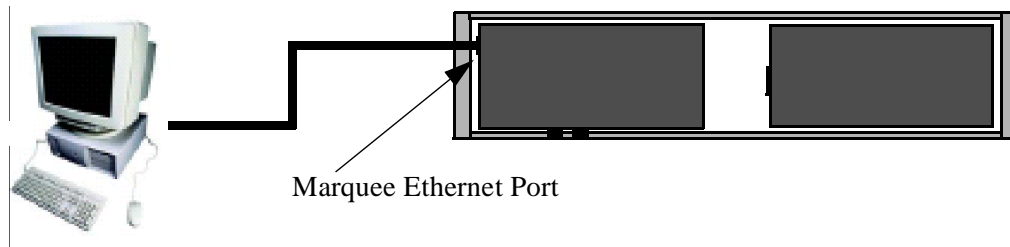

2. Apply power to the Marquee

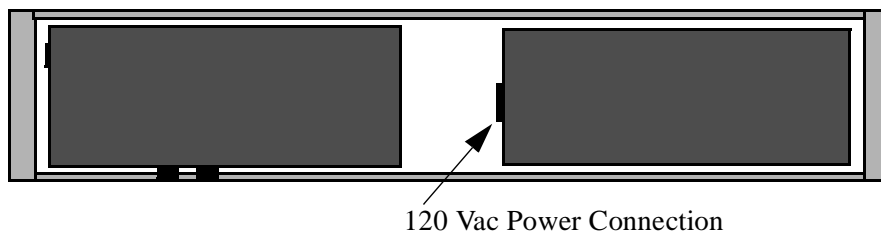

3. Power the PC
4. Configure the PC's ethernet port.
 - IP address 192.168.1.100
 - SubNet Mask 255.255.255.

Note: Refer to the section *Set the PC for Fixed IP Address* for detailed instructions.

4. Start the WEB browser application and enter the IP address of the Marquee in the address field.
In the address bar type **http://192.168.1.200** then press the ENTER key

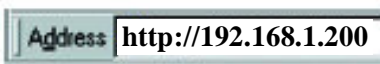

Note: On many browsers the **http://** is automatically added to the address so the user does not need to type it in.

6. At this point the MONITOR page of the Marquee should be displayed in Internet Explorer

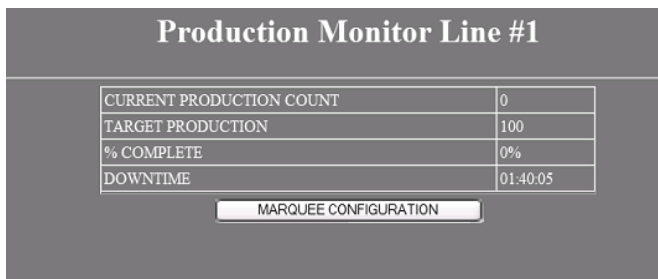
A screenshot of a web page titled 'Production Monitor Line #1'. It contains a table with production statistics and a button for configuration.

Production Monitor Line #1	
CURRENT PRODUCTION COUNT	0
TARGET PRODUCTION	100
% COMPLETE	0%
DOWNTIME	01:40:05

MARQUEE CONFIGURATION

7. The user may now access the configuration WEB pages of the Marquee.

Note: Please refer to the section *Marquee Configuration Pages* for details on the configuration pages.

If the user has problems accessing the Marquee's WEB pages, please follow the detailed steps in the following section.

Detailed Ethernet Setup

This section describes in detail the steps to establish an ethernet connection to the Marquee in order to configure it's operation. This section assumes the user will be using the default ethernet settings of the Marquee. If the user changes the default ethernet settings, such as the IP address, the user must use the new settings in place of the defaults when referenced in this section.

- Default IP address of Marquee 192.168.1.200
- Default SubNet Mask of Marquee 255.255.255.0
- Default Gateway of Marquee 0.0.0.0

This section is for connecting the Marquee directly to the PC. If the user wishes to connect the Marquee to the facility network, it is highly advised that the network administrator or IT department is involved. This is suggested so as the Ethernet network parameters of the Marquee can be configured to match the facility network parameters.

Configuring the PC

The first step in making an Ethernet connection to the Marquee is to configure the PC so as the Ethernet port of the PC can communicate to the Marquee. After the PC has been powered up follow these steps to verify the configuration of the PC.

Note: Prior to making changes to the ethernet configuration of the PC the existing configuration should be documented. The user may be required to revert back to the existing configuration in order to connect to the facility network.

Set the PC for a Fixed IP Address WINDOWS XP

Many facility networks in use today use what is known as DHCP to allow a server on the network to assign ethernet parameters to the PCs that are connected to the network. When connecting directly from the PC to another ethernet device such as the Marquee, the user must assign the Ethernet parameters of the PC manually.

Step 1

On the PC, click on START followed by CONTROL PANEL.

Note: Depending on the operation system of the PC the user may need to select SETTINGS in order to access the CONTROL PANEL.

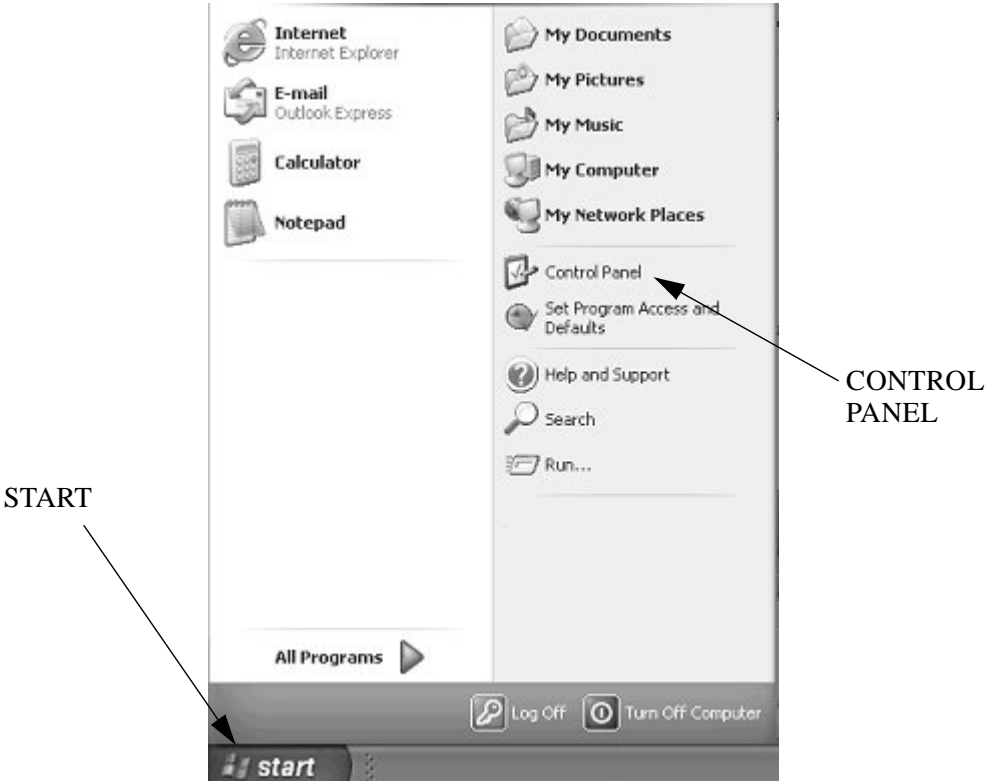

Step 2

In Control Panel double click on NETWORK CONNECTIONS.



Step 3

Under NETWORK CONNECTIONS find the Icon that says LOCAL AREA NETWORK. Then double click on this ICON. This allows the user to configuration the PC's ethernet port.



Step 4

One of two screens will be displayed. If the screen 1 is displayed, click the PROPERTIES button and screen 2 will be displayed.

SCREEN TYPE 1

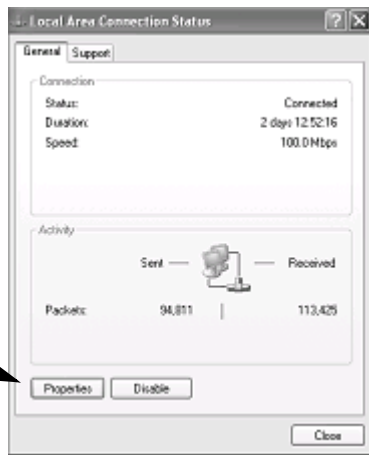

Properties Button

SCREEN TYPE 2

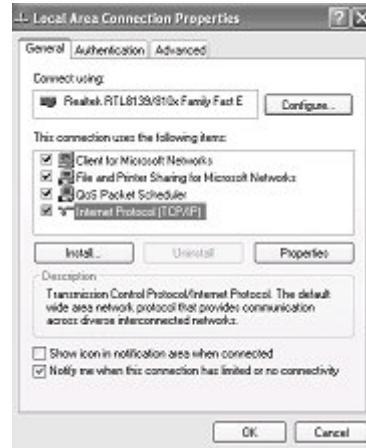

STEP 5

Select selection INTERNET PROTOCOL (TCP/IP) in the THIS CONNECTION USES THE FOLLOWING ITEMS box. Then click the PROPERTIES button.

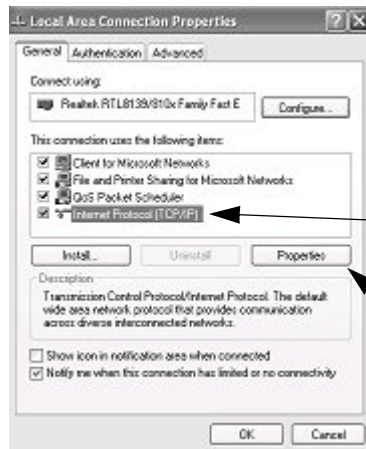

SELECT THIS ENTRY

PROPERTIES BUTTON

STEP 6

The properties for the TCP/IP communications is displayed. If the window looks like the screen below then the PC is set for connecting to as DHCP server. This means that the PC's ethernet parameters are generated by a DHCP server on the facility network. In order to make a direct connection to the Marquee the user must manually enter the Ethernet parameters. To accomplish this first select the item USE THE FOLLOWING IP ADDRESS. At this point the user will enter the IP address 192.168.1.100 and the SubNet Mask of 255.255.255.0.

After entry is completed click the OK button on each of the Network windows. This will cause the PC to accept the changes and reconfigure the local Ethernet port.

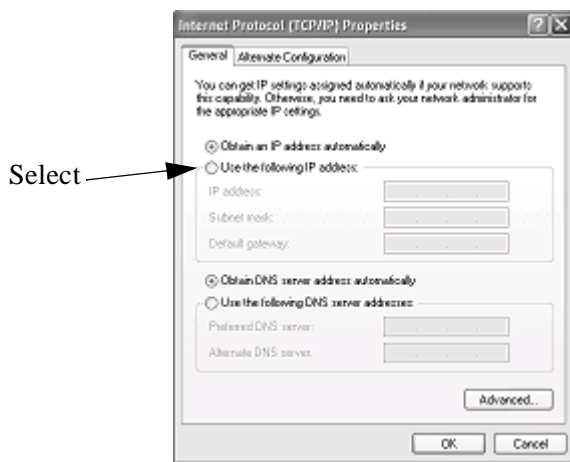

Enter IP address and Subnet Mask

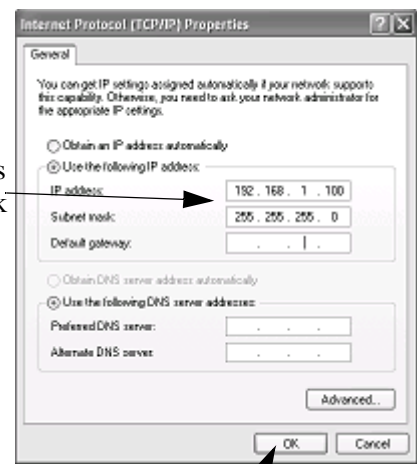

Click OK

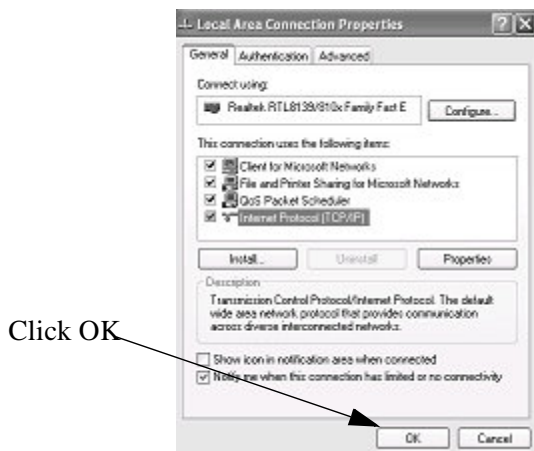

Click Close

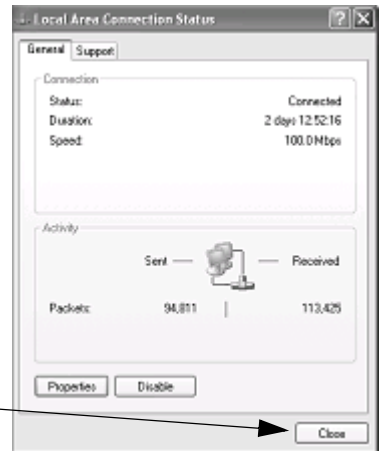

NOTE: THIS SCREEN MAY NOT BE DISPLAYED

Using IPCONFIG To Verify Ethernet Settings

This section is used to verify that the local Ethernet port of the PC is configured properly. In this section a detail description of the use of the IPCONFIG utility is demonstrated.

STEP 1

From the START menu click on the RUN operation.

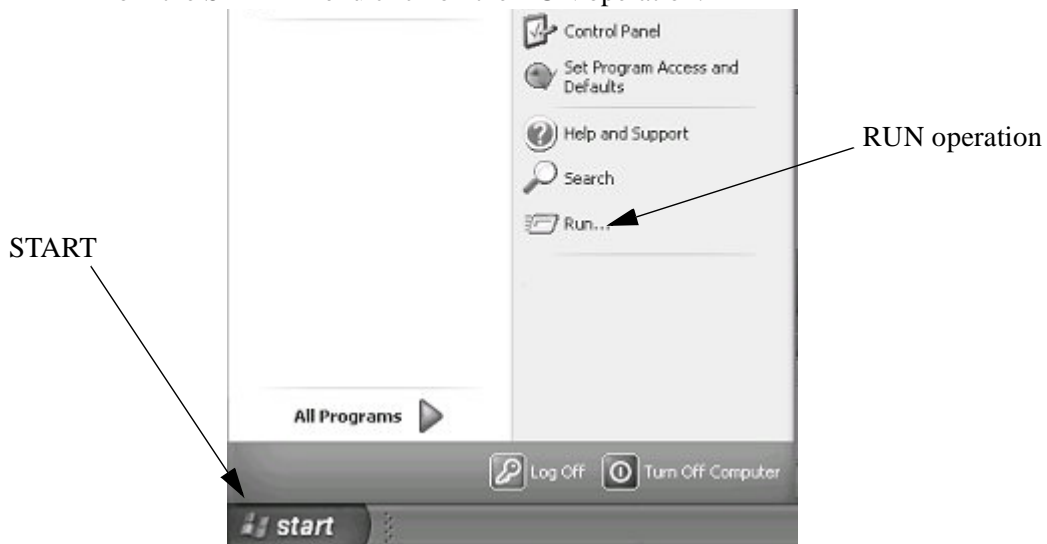

STEP 2

The RUN command entry box will appear. Enter CMD into the open field of this window then click the OK Button. This will allow the user access to the command line entry prompt of WINDOWS.

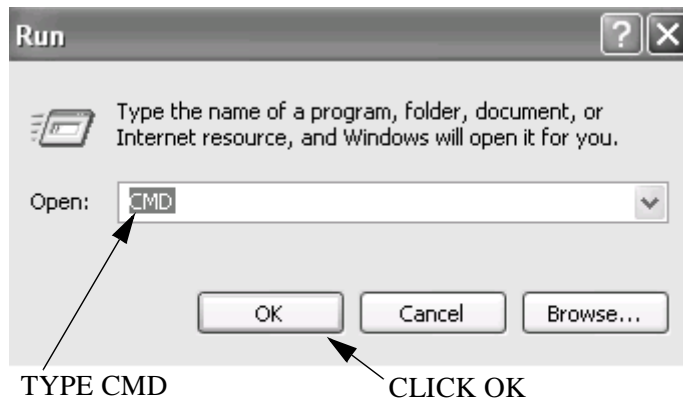

STEP 3

At this point the command line entry is displayed. At the Command Prompt type IPCONFIG and then press the ENTER key of the keyboard.

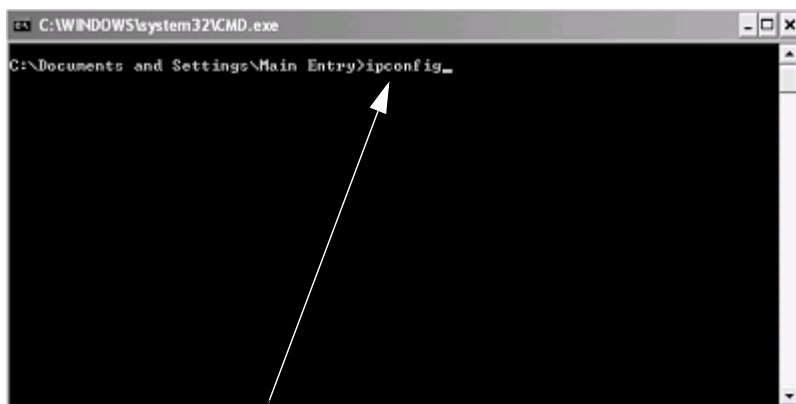

Type IPCONFIG then press the ENTER key

The Ethernet parameters of the PC's Ethernet port will be displayed. Verify that the IP address and Subnet mask match the entries previously entered. If the parameters do not match type:

- Verify that the parameters were entered correctly in the Network Properties window from the previous procedure.
- Reboot the PC and repeat this procedure.

Note: If the user is unable to successfully set the Ethernet parameters please consult the facility IT department or network administrator.

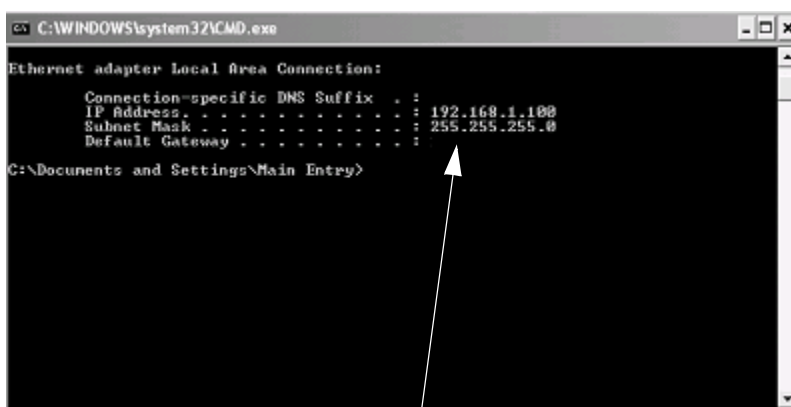

Ethernet Parameters for Local Port

Connecting The PC To The Marquee

Cable Description

This section discussing the steps to connect the Marquee directly to the PC.

There are two types of Ethernet cables available in today's market.

A patch or straight cable is used when connecting an Ethernet device to a Switch or HUB.

A Cross Over cable is used when connecting one Ethernet Device, such as a PC, to another Ethernet Device, such as the Marquee, without a HUB or Switch. This is known as a direct connection and requires that the Ethernet cable crosses the Ethernet signals. A Cross Over cable is included with the Marquee for this purpose. If the user is connecting the Marquee to a HUB or Switch, the user must supply the Patch or Straight Through cable.

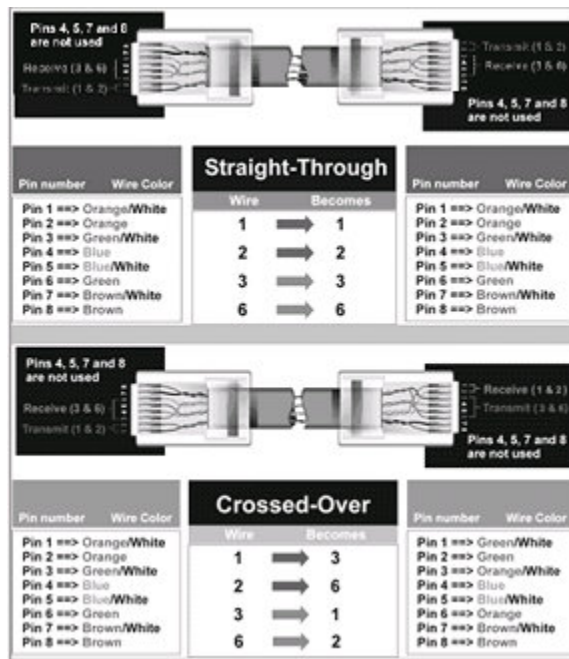
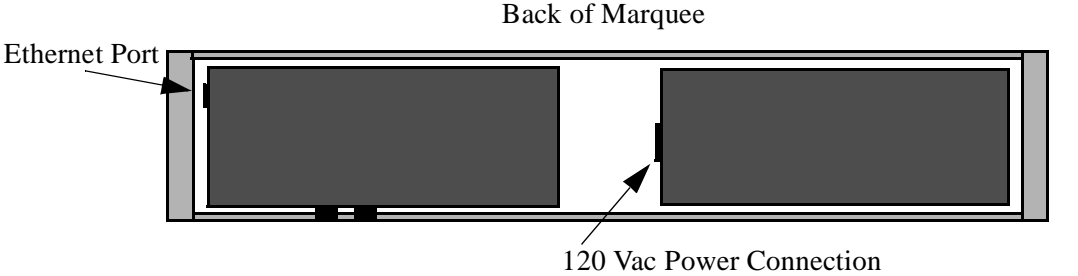

Figure 1—Ethernet Cable Pinouts

Connecting the Ethernet Cable

Prior to connecting the Marquee to the PC, both the PC and Marquee should be powered down.
Connect the Cross cable to the Ethernet port of the marquee. The Ethernet port is located on the right side of the Marquee.



Connect the other end of the Cross cable to the PC's Ethernet Port.

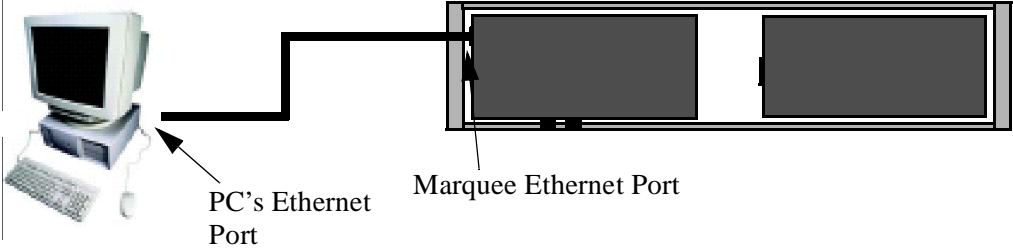

Power up both the PC and Marquee. After the PC has booted the user should check that the LINK light of the PC's Ethernet port is lit. The LINK light is lit when a physical connection is made between the PC's ethernet port and another Ethernet device, such as the Marquee. If the LINK light is lit then the PC is properly connected to the Marquee.

If the LINK light is not lit check the following:

- Verify the Marquee is powered
- Verify the cable is a cross over cable
- Verify the Ethernet port of the PC is Enabled

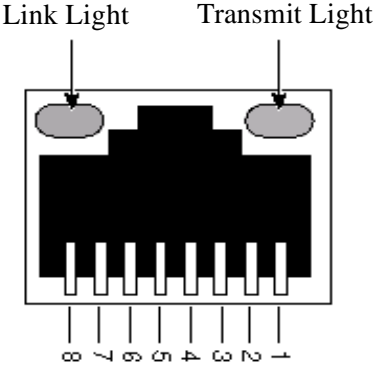

Verifying Ethernet Communications

The previous section verified the physical connection between the Ethernet port of the PC and the Marquee. This section will be used to verify a communication connection exists between the Marquee and the PC.

In order to communicate to the Marquee a communication connection must be established. The physical connection indicates that communication can physically occur but does not verify that the Ethernet parameters match between the Marquee and the PC. This section is used to verify the Ethernet Parameters of both the PC and Marquee.

STEP 1

On the PC, click START followed by RUN.



STEP 2

The RUN command entry box will appear. Enter CMD into the open field of this window then click the OK Button. This will allow the user access to the command line entry prompt of WINDOWS.

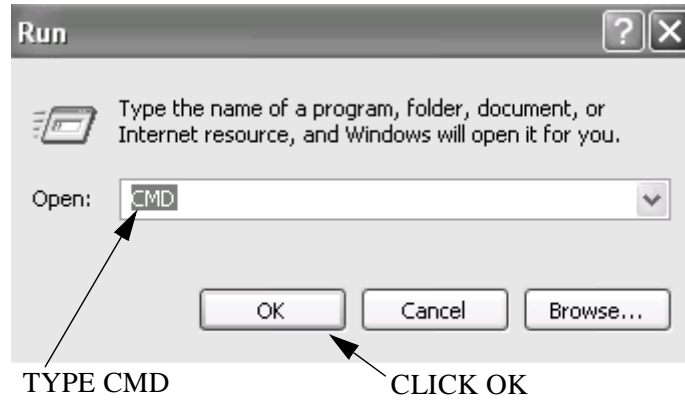

STEP 3

At this point the command line entry is displayed. At the Command Prompt type PING 192.168.1.200 and then press the ENTER key of the keyboard. This operation sends a low level command to verify that communications can be established. The following screen shots display the three different responses that may occur during this operation along with the description of the response.

Reply From

This is an indication that Ethernet communication is established to the Marquee. Proceed to next section.

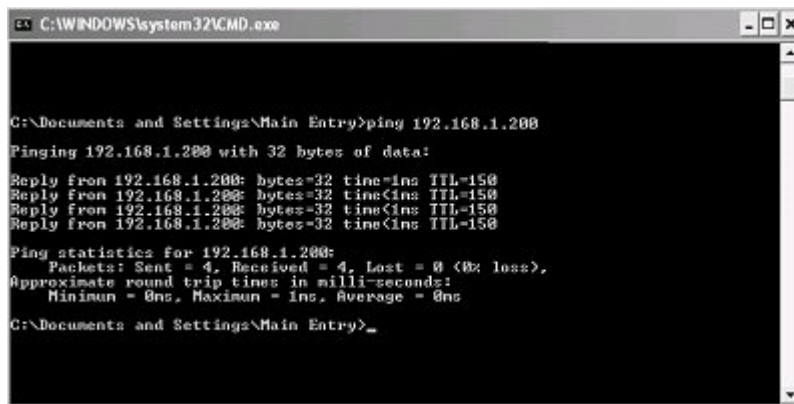

```
C:\WINDOWS\system32\CMD.exe

C:\Documents and Settings\Main Entry>ping 192.168.1.200
Pinging 192.168.1.200 with 32 bytes of data:
Reply from 192.168.1.200: bytes=32 time=1ms TTL=150
Reply from 192.168.1.200: bytes=32 time<1ms TTL=150
Reply from 192.168.1.200: bytes=32 time<1ms TTL=150
Reply from 192.168.1.200: bytes=32 time<1ms TTL=150

Ping statistics for 192.168.1.200:
    Packets: Sent = 4, Received = 4, Lost = 0 (0% loss),
    Approximate round trip times in milli-seconds:
        Minimum = 0ms, Maximum = 1ms, Average = 0ms
C:\Documents and Settings\Main Entry>_
```

Request timed out

This indicates that the connection to the Marquee could not be established.

- Verify the IP address and Subnet Mask are correct on the Marquee
- Verify cabling and LINK light is lit
- Verify Ethernet settings of PC

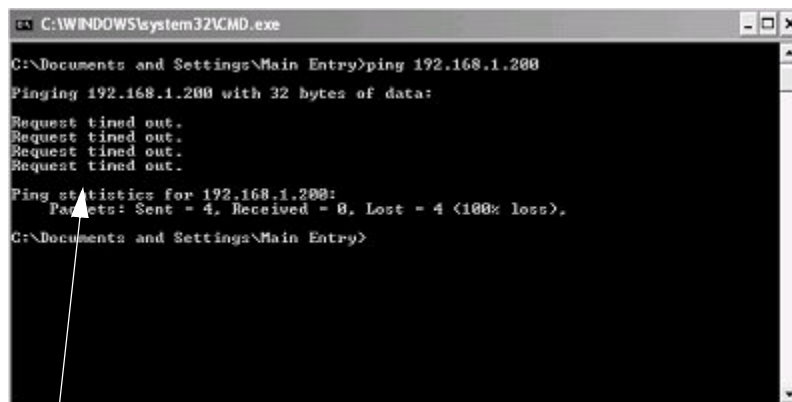

```
C:\WINDOWS\system32\CMD.exe
C:\Documents and Settings\Main Entry>ping 192.168.1.200
Pinging 192.168.1.200 with 32 bytes of data:
Request timed out.
Request timed out.
Request timed out.
Request timed out.
Ping statistics for 192.168.1.200:
    Packets: Sent = 4, Received = 0, Lost = 4 (100% loss),
C:\Documents and Settings\Main Entry>
```

Response

Destination Host Unreachable

This is an indication that the PC's Ethernet settings are not correct. This is a common error when the IP address or Subnet mask is set incorrectly.

- Verify the PC's Ethernet settings
- Reboot pc

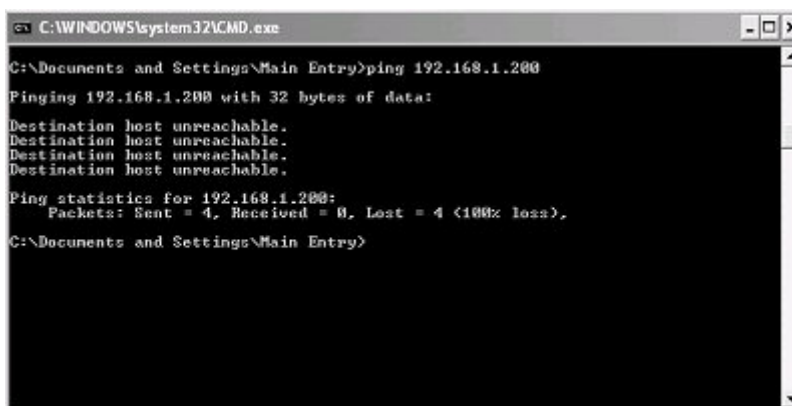

```
C:\WINDOWS\system32\CMD.exe
C:\Documents and Settings\Main Entry>ping 192.168.1.200
Pinging 192.168.1.200 with 32 bytes of data:
Destination host unreachable.
Destination host unreachable.
Destination host unreachable.
Destination host unreachable.
Ping statistics for 192.168.1.200:
    Packets: Sent = 4, Received = 0, Lost = 4 (100% loss),
C:\Documents and Settings\Main Entry>
```

Connecting To the Marquee's WEB Server

In this section a detailed explanation of the steps that are used to access the built in WEB sever of the Marquee will be covered.

There are many different WEB browser software packages available on the market today. In this section a general overview of WEB browser settings are discussed. Most WEB browsers support the settings discussed in this section. The user should reference documentation specific to the WEB browser that is being used to determine how settings are configured within a given WEB browser.

Note: In most cases no setting changes are required to the WEB browser. Only in specific cases is this required.

Step 1

Start the WEB Browser on the PC.

Step 2

In the Address Bar type HTTP://192.168.1.200.

Note: 192.168.1.200 is the default IP address of the Marquee. If this has been changed by the user, change the IP address to match the IP address of the Marquee.

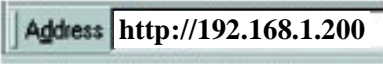

Note: On many browsers the **http://** is automatically added to the address so the user does not need to type it in.

Step 3

At this point one of two items will be displayed in the WEB Browser.

Marquee's Monitor Screen Appears

This is an indication that the WEB browser has established a connection to the Marquee's WEB server. The user can now proceed to configure the Marquee.

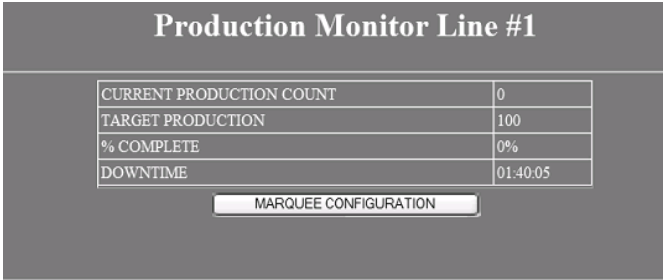

No Monitor Page is Displayed

The Monitor page is not displayed and a message such as WEB PAGE CAN NOT BE LOADED or FOUND. This error can be caused by the WEB browser's settings not being configured properly. The most common reasons for this error are listed below.

Note: It is assumed the user has followed the proceeding sections to verify Ethernet communication to the Marquee. If not please refer to these sections to verify that the Ethernet settings of the PC are correct.

WEB browser using wrong Ethernet Connection

In many PCs, such as a laptop, more than one Ethernet connection exists. In many cases a wireless Ethernet connection exist on the PC and because of this the WEB browser uses this connection as the default Ethernet Connection.

The solution for this is to DISABLE all Ethernet connections except the LOCAL Ethernet port.

STEP 1

Click on START followed by Control Panel.

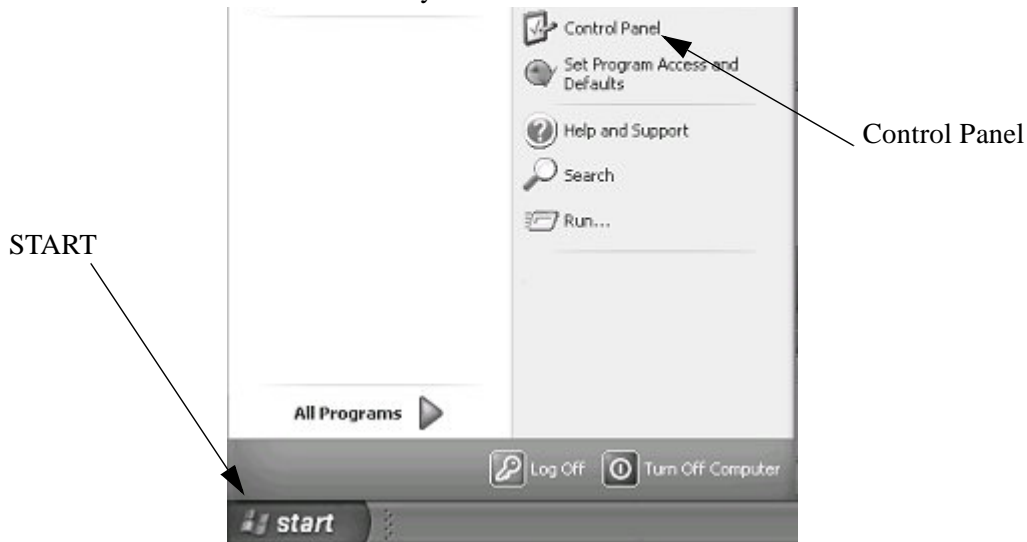

STEP 2

Click on NETWORK CONNECTIONS.



STEP 3

Right click on each Network connection other than the LOCAL CONNECTION and select DISABLE.

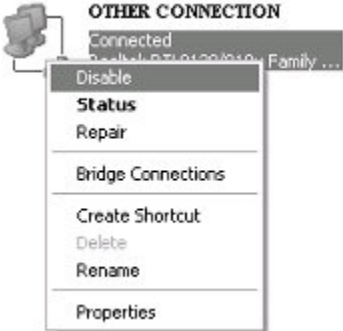

STEP 4

Restart PC and then restart the WEB browser.

WEB Browser Using Proxy server

In many facility networks, the WEB browser does not make a direct connection to the Internet. In these cases a PROXY server is connected to the network and the WEB server connects to this PROXY server to access WEB pages. When directly connecting to a WEB server, such as the Marquee this setting within the WEB browser must be turned off. Follow these steps to disable the PROXY server.

STEP 1

Open the WEB browser.

STEP 2

Within the WEB browser select TOOLS followed by INTERNET OPTIONS

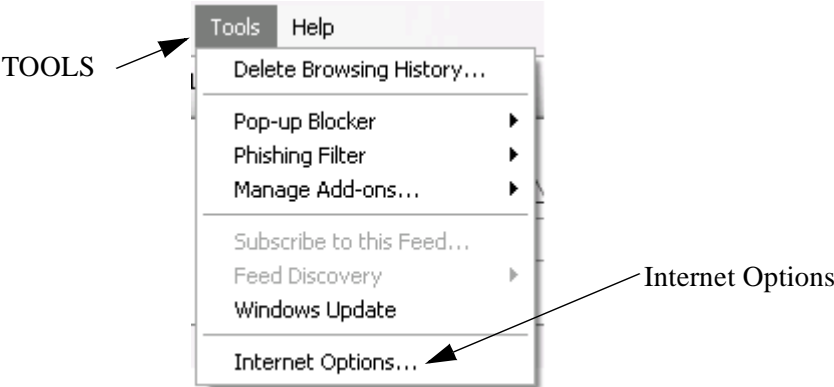

Making The Ethernet Connection

Detailed Ethernet Setup

STEP 3

The following screen will be displayed. Select the CONNECTIONS TAB. Followed clicking on LAN SETTINGS.

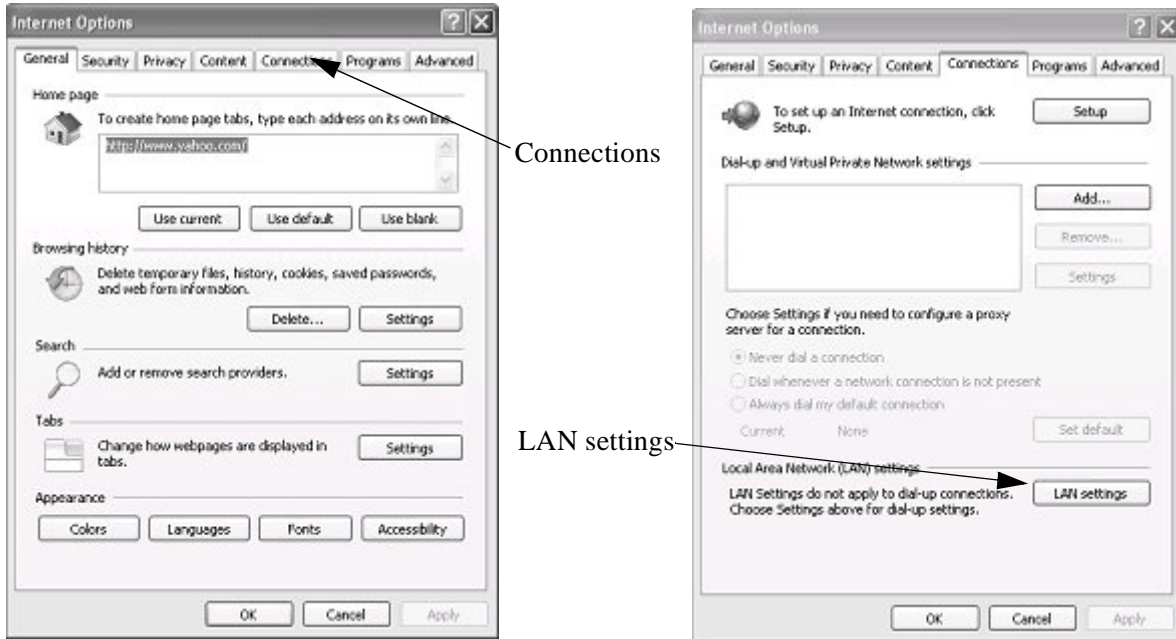

STEP 4

IF selected, deselect PROXY SERVER. Click OK on all windows and restart the WEB BROWSER.

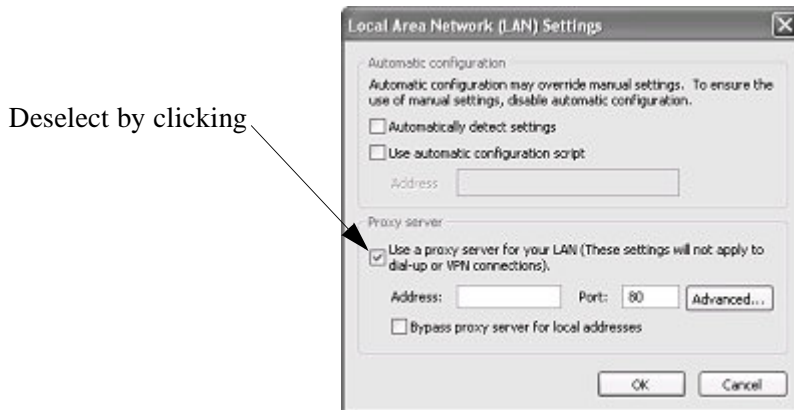

—Chapter 3—

Marquee WEB Pages

This chapter discusses the WEB page configuration menus of the Marquee. The Marquee has a built in WEB server so as the user may use any WEB browser to open the configuration pages and configure the Marquee for the application at hand. This chapter is designed to give in depth information about each configuration page. The next chapter gives the user sample setups that a user can use in order to accomplish some standard tasks.

MAIN PAGE

The Main page is the initial page that is displayed when the user opens a WEB browser and types in the IP address of the Marquee. The Main Display Page displays the current message that is being displayed on the Marquee (Note: The entire message is displayed as 1 line though it may display as multiple lines on the marquee).

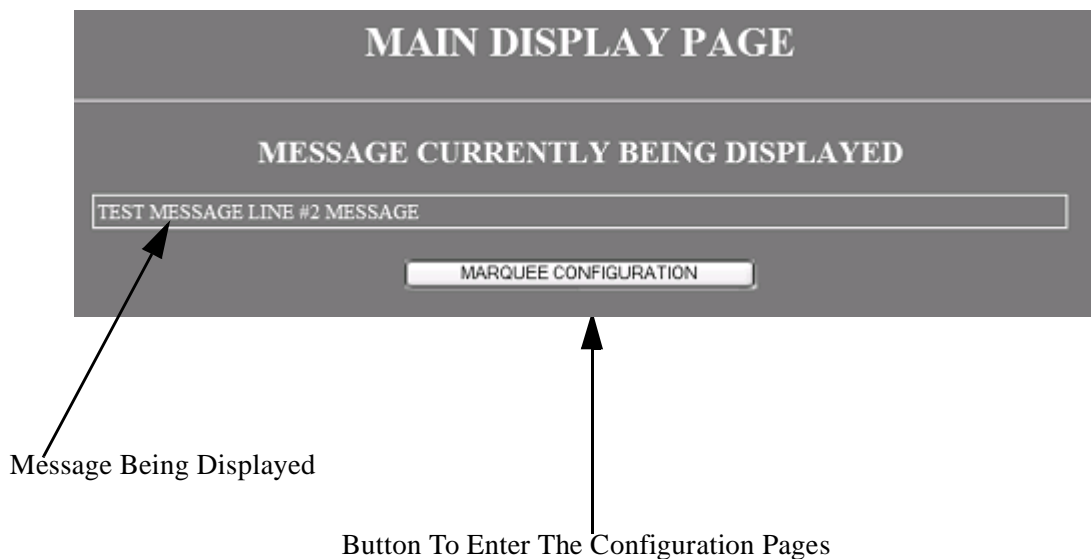

Figure 1—Main Page

Access Configuration Pages

Access to the configuration pages is password protected. This feature allows only designated users the ability of changing the Marquee configuration. To access the configuration pages click the MARQUEE CONFIGURATION button. A password entry screen will be displayed.

Note: The default user name is **admin** and the default password is **admin** this may be changed in the NETWORK CONFIGURATION page.

WARNING—*If the user name or password are changed please record the new setting and store them in a safe location for future reference.*

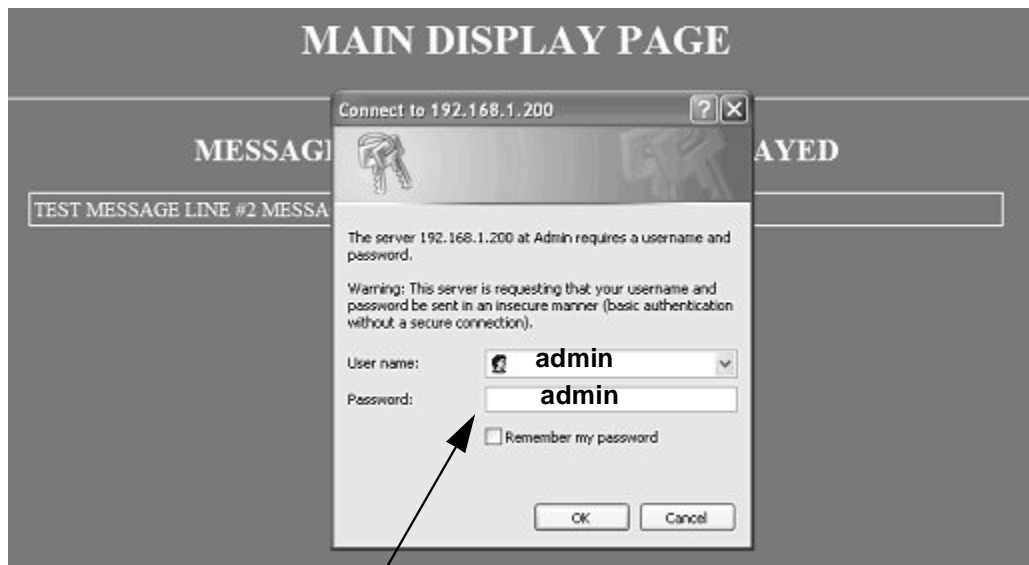

User defined user name and password (default **admin**)

Figure 2—Password Entry Page

SETUP MENU

The setup menu allows the user to access the Marquee configuration pages. This page consists of 4 configuration page access buttons and a return button.

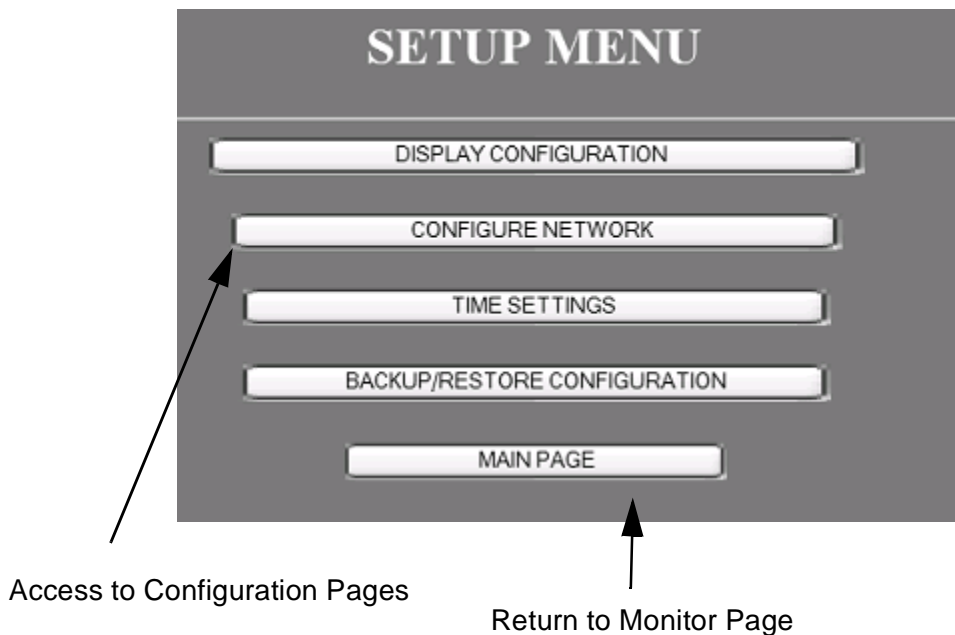
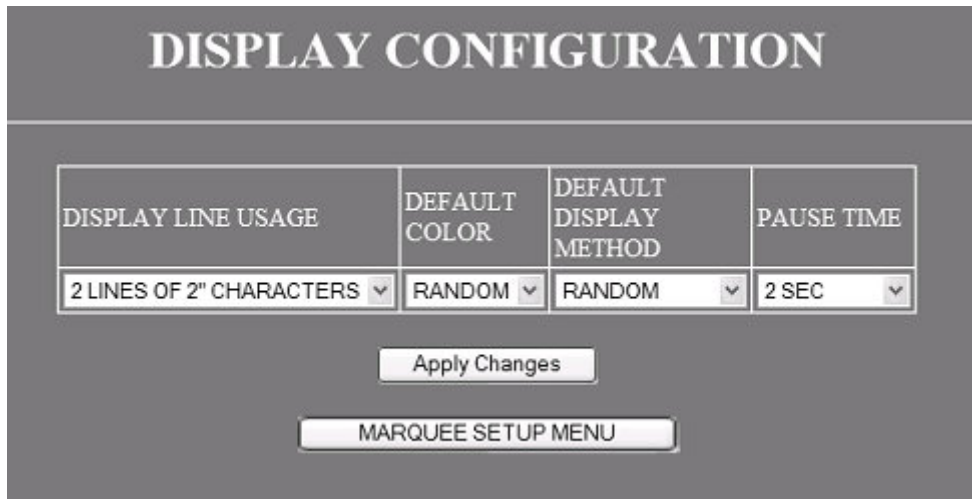

Figure 3—Setup Menu Page

Note: A common operation within all configuration pages is that the APPLY button must be clicked prior to leaving the page in order for any changes that have been made to take affect. If the user leaves the page prior to clicking on the APPLY button any changes made on that page will be discarded.

DISPLAY CONFIGURATION

This page allows the configuration of how the display will be used along with the default display mode, color and message pause time. The default color and display method are used when the UDP message sent to the display does not contain identifiers for this operation. Refer to UDP MESSAGING chapter for more details.



DISPLAY LINE USAGE	DEFAULT COLOR	DEFAULT DISPLAY METHOD	PAUSE TIME
2 LINES OF 2" CHARACTERS ▾	RANDOM ▾	RANDOM ▾	2 SEC ▾

Figure 4—Message And Data Display Configuration Page

DISPLAY LINE USAGE

This selection box allows the user to specify how the display will be used for display of messages. There are two choices for the display operation either 2 lines of 2" characters or 1 line of 4" characters.

DEFAULT COLOR

The Marquee is a tri-color display. The display supports 4 color modes, red, green, yellow or random colors. This selection is used to determine the color of the characters to be displayed if the UDP message sent to the display does not contain a color modifier command.

DEFAULT DISPLAY METHOD

Display method is how the message is displayed on the Marquee. The Marquee has 24 display methods. This selection is used as the default method for displaying the message in no method modifier is supplied in the UDP message.

PAUSE TIME

Pause time is time between the display being updated. An example of this is if the message sent to the display is too big to display at one time then the display will display one portion of the message followed by the second portion. The time that the first portion is displayed before displaying the second portion is the pause time.

NETWORK CONFIGURATION

This page is used to configure the Marquee's built-in ethernet network.

Note: If the Marquee is to be connected to the plant network, the IT department or network administrator of your facility should be consulted prior to assigning ethernet network parameters.

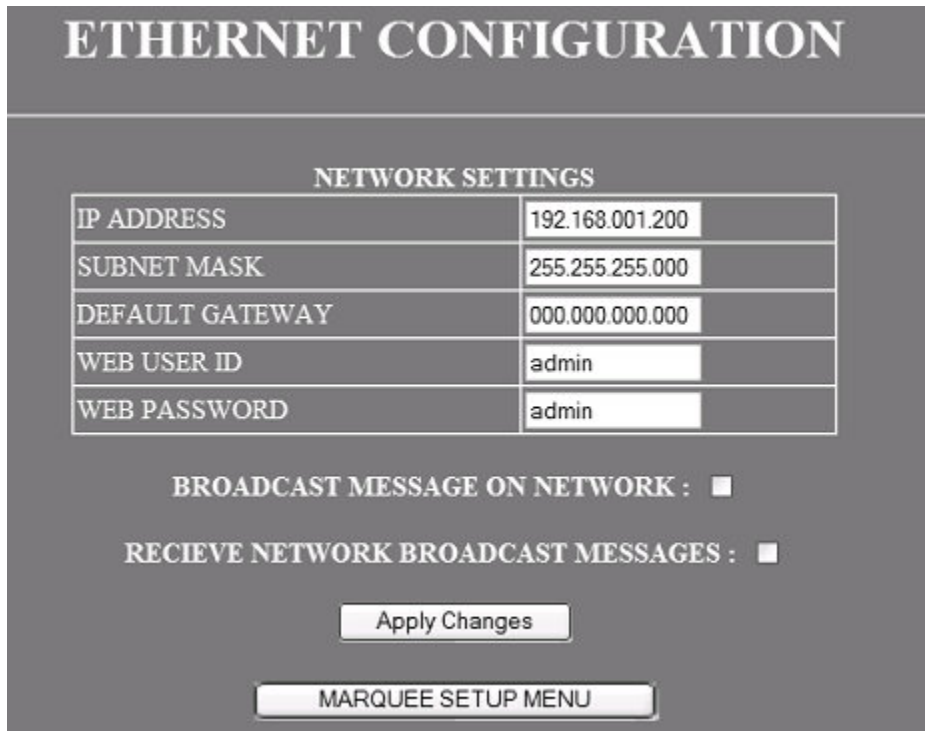

The screenshot displays the 'ETHERNET CONFIGURATION' page. At the top, the title 'ETHERNET CONFIGURATION' is centered. Below it, a section titled 'NETWORK SETTINGS' contains a table with five rows. The first row is 'IP ADDRESS' with the value '192.168.001.200'. The second row is 'SUBNET MASK' with the value '255.255.255.000'. The third row is 'DEFAULT GATEWAY' with the value '000.000.000.000'. The fourth row is 'WEB USER ID' with the value 'admin'. The fifth row is 'WEB PASSWORD' with the value 'admin'. Below the table, there are two checkboxes: 'BROADCAST MESSAGE ON NETWORK : ' and 'RECIEVE NETWORK BROADCAST MESSAGES : '. At the bottom of the form, there are two buttons: 'Apply Changes' and 'MARQUEE SETUP MENU'.

NETWORK SETTINGS	
IP ADDRESS	192.168.001.200
SUBNET MASK	255.255.255.000
DEFAULT GATEWAY	000.000.000.000
WEB USER ID	admin
WEB PASSWORD	admin

BROADCAST MESSAGE ON NETWORK :

RECIEVE NETWORK BROADCAST MESSAGES :

Apply Changes

MARQUEE SETUP MENU

Figure 5—Ethernet Configuration Page

NETWORK SETTINGS

This section is used to configure the Ethernet parameters and configuration page access parameters.

IPADDRESS

This field is used to specify the IP address of the built-in ethernet port of the Marquee. If an invalid IP address is entered by the user it will be rejected when the APPLY button is clicked.

SUBNET MASK

This field is used to specify the SubNet mask used by the built-in ethernet port of the Marquee. If an invalid SubNet mask is entered by the user it will be rejected when the APPLY button is clicked.

DEFAULT GATEWAY

This field is used to specify the Default Gateway used by the built-in ethernet port of the Marquee. If an invalid Default Gateway is entered by the user it will be rejected when the APPLY button is clicked.

WEB USER ID

This field is used to specify the user ID that is used when accessing the configuration pages of the MARQUEE.

Note: If a change is made to this field and then the APPLY button is clicked, the user will be disconnected from the Marquee. The user must then restart the browser and log back into the Marquee with the new WEB USER NAME and/or WEB PASSWORD to continue configuration.

WEB PASSWORD

This field is used to specify the password that is used when accessing the configuration pages of the MARQUEE.

Note: If a change is made to this field and then the APPLY button is clicked, the user will be disconnected from the Marquee. The user must then restart the browser and log back into the Marquee with the new WEB USER NAME and/or WEB PASSWORD to continue configuration.

BROADCAST MESSAGE ON NETWORK

This selection allows the user to specify whether or not the Marquee will broadcast the message that is received across the Ethernet Network. The purpose of this function is to reduce both the time for application development and network traffic. If this selection is checked, upon receiving a UDP message the Marquee will rebroadcast the message on the network. Any Marquee that has been configured to receive the broadcast message will then display the same message as the broadcaster.

RECIEVE NETWORK BROADCAST MESSAGES

This selection allows the user to specify that the Marquee will allow receiving of broadcast messages. If this selection is checked, upon a Marquee broadcasting a message the Marquee will display the broadcast message.

TIME SETTINGS PAGE

The TIME SETTINGS page is used to configure the real time clock operations of the Marquee.

TIME CONFIGURATION

ALLOW NETWORK TIME SYNC.

USE AS MASTER CLOCK (BROADCASTS TIME)

BROADCAST TIME EVERY MINUTES

TIME AND DATE DISPLAY FORMAT

TIME	DATE
<input type="text" value="24-HOUR HH:MM"/>	<input type="text" value="DD MMM YYYY"/>

ALLOW NETWORK TIME SYNC.

This option allows the Marquee's real time clock to be synchronized to a master clock on the network. In order for this to operate, a marquee on the same network must be defined as a master clock. The master clock Marquee broadcasts a time sync message that any Marquee that is configured to ALLOW NETWORK TIME SYNC. received the sync message and updates it's real time clock.

USE AS MASTER CLOCK

This option is used to specify that this Marquee is the master clock on the network. In turn the Marquee will broadcast the current time and date to all other Marquees that are defined to receive the network time sync.

BROADCAST TIME EVERY

If the Marquee is defined as the master clock, this selection allows the user to specify how often to transmit the time and date onto the network.

TIME AND DATE DISPLAY FORMAT

This section allows the user to specify how time and date will be displayed on the Marquee.

TIME

Selection for how time will be displayed if included within a message.

Table 1—Time Display Format

SELECTION	DISPLAYED
24 HOUR HH:MM	Displays time in 24 hour format including hour and minute only
24 HOUR HH:MM:SS	Displays time in 24 hour format including hour, minute and seconds.
12 HOUR HH:MM AM/PM	Displays time in 12 hour format AM/PM with hour and minute only.
12 HOUR HH:MM:SS AM/PM	Displays time in 12 hour format AM/PM including hour, minute and second.

DATE

Selection for how the date will be displayed if included within a message.

Table 2—Date Display Format

SELECTION	DISPLAYED	EXAMPLE
DD MMM YYYY	Displays day of month, 3 character month abbreviation and 4 digit year.	25 Dec 2005
MMM DD YYYY	Displays 3 character month abbreviation, day of month and 4 digit year.	Dec 25 2005
DD/MM/YYYY	Displays day of month/month/4 digit year.	25/12/2005
MM/DD/YYYY	Displays month/day of month/4 digit year.	12/25/2007
YYYY.MM.DD	Displays 4 digit year.month.day of month.	2005.12.25

BACKUP AND RESTORE PAGE

This page allows the user to backup the Marquee configuration onto the PC or restore/load a previously stored configuration into the Marquee.

BACKUP AND RESTORE

LOAD AN EXISTING MARQUEE FILE

Browse... Restore

SAVE CURRENT MARQUEE CONFIGURATION TO A FILE Backup

MARQUEE SETUP MENU

LOAD AN EXISTING MARQUEE FILE

BROUSE

This button opens the file explorer so the user may find the file to restore/load into the Marquee.

RESTORE

After a configuration file has been specified, this button initiates the transfer of the file to the Marquee.

SAVE CURRENT MARQUEE CONFIGURATION TO A FILE

This button is used to initiate the saving of the configuration of the Marquee to a file on the PC. Upon pressing this button the user selects SAVE and specifies the location to save the configuration file. Please note that the file name may be changed to better describe the configuration being saved.

UDP MESSAGING

This chapter describes the operation and options available to the user for sending UDP messages to the Marquee.

WHAT IS UDP?

User Datagram Protocol (UDP) is one way of sending data over an Ethernet network. Using UDP, programs on network computers can send short messages sometimes known as datagrams to one another. UDP is sometimes called the Universal Data Protocol. Many of today's PC programming packages along with industrial products such as a PLC support UDP communications. UDP is also designed to support broadcast mode which allows a single message to be sent from a system and then received by multiple devices.

HOW IS UDP IMPLEMENTED IN THE MARQUEE?

Full UDP functionality is supported by the Marquee.

PORT

The port address used for receiving UDP messages is 2010. Any data received on this port of the Marquee will be read and displayed on the Marquee.

IP ADDRESS SPECIFIC

If the user wishes to send a message to a given Marquee on the network then the Marquee IP address is used during the message transfer. In the UDP message transmission, the user must supply the IP address of the Marquee that they wish to send the message. The port is always the same and is 2010.

BROADCAST MESSAGE

If the user wishes to send a message to all Marquees on the system then the user specifies the broadcast IP address (255.255.255.255). Upon sending a message to port 2010 with the broadcast IP address, all Marquees on the network will display the same message.

FORMATING MESSAGE

In the simplest system, the text/data to be displayed is sent to the Marquee. If nothing more than the text/data is transmitted out the UDP message then the DEFAULT COLOR and DEFAULT DISPLAY METHOD is used to display the text/data.

In other cases the user may wish to change the color of certain pieces of text/data or change the manor the message is displayed on the Marquee. This changing of the default color and display method is accomplished by adding what is called a MODIFIER.

A MODIFIER can be used to override the default color or display mode of the Marquee. The user simple inserts the modifier in the message being sent and then the Marquee adjust it's operation accordingly. A color modifier always start with an @ follow by a one character color code.

SIZE CHANGED MODIFIERS

The follow table lists the size change modifiers that may be embedded within the message to change the character size of text/data of the message. If a modifier is included within the message then all text/data following this modifier will be the size specified. If a second modifier is included then the text/data of the message that follows this modifier will be the specified size.

Table 1—SIZE MODIFIERS

MODIFIER	SIZE
@2	Text/data following this modifier will be 2 inch.
@3	Text/data following this modifier will be 3 inch.
@4	Text/data following this modifier will be 4 inch.

COLOR CHANGED MODIFIERS

The follow table lists the color change modifiers that may be embedded within the message to change the color of text/data of the message. If a modifier is included within the message then all text/data following this modifier will be the color specified. If a second modifier is included then the text/data of the message that follows this modifier will be the specified color.

Table 2—Color Modifiers

MODIFIER	COLOR
@R or @r	Text/data following this modifier will be red.
@G or @g	Text/data following this modifier will be green.
@Y or @y	Text/data following this modifier will be yellow.

EXAMPLE:

Message sent without modifiers: THIS IS MESSAGE #1

This message will be displayed in the DEFAULT COLOR.

Message sent with modifiers: THIS@r IS@g MESSAGE@y #1

In this case the word THIS will be the DEFAULT COLOR, the word IS will be RED, the word MESSAGE will be GREEN and the #1 will be YELLOW.

DISPLAY METHOD MODIFIERS

Display method is the method the Marquee displays the received message. There are 26 different ways that a message may be displayed on the Marquee. If no modifier is received with the message then the DEFAULT DISPLAY METHOD is used to display the message. The display method modifier is always placed at the beginning of the message. The display method modifier also always starts with a ~ followed by a capital letter A-Z.

Note: The display method modifier must be the first two characters within the message.

Table 3—Display Method Modifiers

DISPLAY METHOD MODIFIER	RESULT OF MESSAGE BEING DISPLAYED
~A	RANDOM: Display method is randomly chosen.
~B	IMMEDIATE: Message is displayed as soon as it is received.
~C	SLIDE <--: Message slides in from right side of the Marquee
~D	SLIDE -->: Message slides in from left side of the Marquee.

Table 3—Display Method Modifiers

DISPLAY METHOD MODIFIER	RESULT OF MESSAGE BEING DISPLAYED
~E	SLIDE <-->:Message slide out from Middle of the Marquee.
~F	SLIDE --<:Message slide in from both right and left sides.
~G	SLIDE UP: Message slides up from bottom of the Marquee.
~H	SLIDE DOWN: Message slides down from top of the Marquee.
~I	COVER <--: Message starts covering existing display from right.
~J	COVER -->:Message starts covering existing display from left.
~K	COVER <-->:Message starts covering existing display from the center.
~L	COVER --<:Message starts covering existing display from both right and left.
~M	COVER UP: Message starts covering existing display from top down.
~N	COVER DOWN: Message starts covering existing display from bottom up.
~O	ROLL <--:Message rolls in from right as old message rolls out on left.
~P	ROLL -->Message rolls in from left as old message rolls out on right.
~Q	ROLL --<: Message rolls in from left and right.
~R	ROLL <-->:Message rolls from center to left and right.
~S	ROLL UP: Message rolls in from bottom as old message rolls out on top.
~T	ROLL DOWN: Message rolls in from top as old message rolls out on bottom.
~U	SNOW: Pixels of message characters snow down from the top of the Marquee
~V	SHOOT: Message characters shoot onto the Marquee from right.
~W	EXPLODE: Message appears after each character is exploded
~X	TWINKLE: All pixels of displayed characters twinkle.
~Y	SCROLL: Message scrolls from bottom line to top line continuously.
~Z	ROTATE: Message continually rotates across the display from right to left.

EXAMPLE:

Message sent to Marquee no modifier: THIS IS MESSAGE #1

Since no DISPLAY METHOD MODIFIER is specified the message will be displayed using the DEFAULT DISPLAY METHOD.

Message with modifier: ~ZTHIS IS MESSAGE #1

This message will rotate from right to left on the Marquee.

SPECIAL MODIFIERS

Special modifiers can be used to modify the way the message, or portions of the message are displayed. There are also special modifiers that allow the user to embed the time and date within the message without sending this data. A table of these modifiers is below.

Note: When time or date is embedded with the modifier, the Marquee will display the time and date information in it's real time clock system.

Table 4—Special Modifiers

SPECIAL MODIFIER	OPERATION
@N or @n	Forces characters after this modifier to the next line of the display.
@T or @t	Displays the time from the Marquee's real time clock
@D or @d	Displays the date from the Marquee's real time clock.
@B or @b	Characters following this modifier will be displayed in a bold font.*
@W or @w	Characters following this modifier will be displayed in a wide font.*
@F or @f	Characters following this modifier will flash.*

*If a second modifier of this type is sent, then the characters after the second modifier will go back to default display mode.

EXAMPLES:

Message sent to Marquee: LINE #1@NLINE #2

The Marquee will display LINE #1 on the top line and LINE #2 on the bottom line.

Message sent to Marquee: THE TIME IS @T

The Marquee will display the time of the real time clock.

Message sent to Marquee: @FFLASH TEST

The text FLASH TEST will flash as it is displayed on the Marquee

Message sent to Marquee: @FFLASH@F TEST

Only the word FLASH will flash on the Marquee.

UDP MESSAGING

—Chapter 5—

Mounting Instructions

This chapter will discuss the mounting possibilities available. Mounting hardware is included with each Marquee.

Mounting Hardware Included



Mount Attachment
Nut 5/16 Qty 4



Slide-In Mount Attachment
Bolt 5/16 (custom) Qty 4



Mount Interconnect
Nut 6mm Qty 4



Mount Interconnect
Bolt 6mm Qty 4

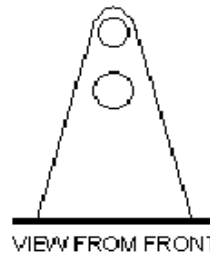

VIEW FROM FRONT

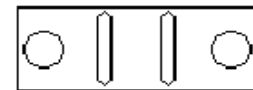

VIEW FROM BOTTOM

Hanger/Stand Mounting Bracket Qty 2

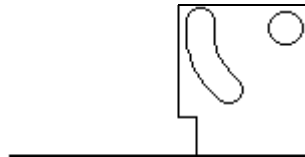

View from Front



View From Bottom

Swivel Mount Bracket

Installing Mount Attachment Bolts

Prior to mounting the Marquee the mount attachment bolts must be installed.

WARNING—In order to install the mount attachment bolts the end cap on the left (when looking at front of Marquee) must be removed.

WARNING—DO NOT REMOVE THE END CAP ON THE RIGHT HAND SIDE!

1. Remove 4 screws holding left END CAP. (A)
2. Remove END CAP.(B)
3. Slide 2 to 4 mount bolts into groove. (C)
4. Replace END CAP.
5. Place 4 END CAP screws.

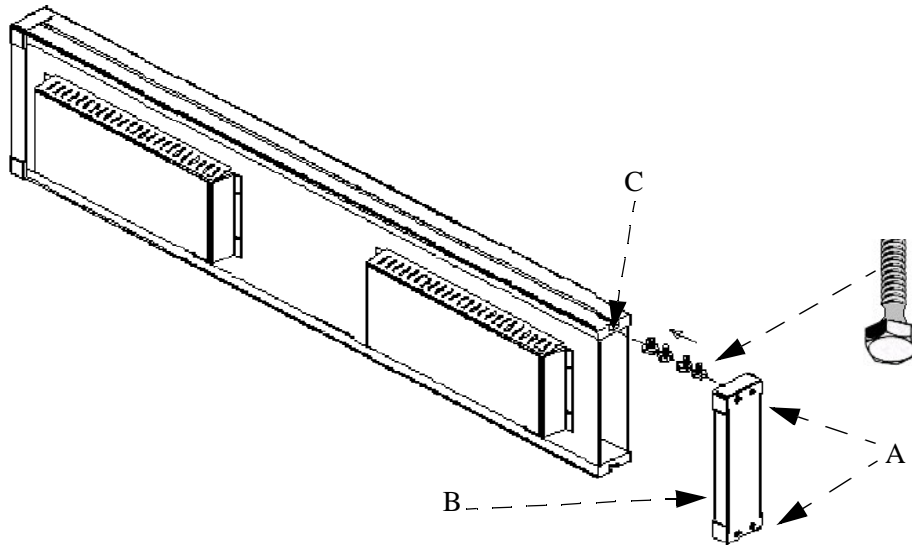

Figure 1—Installing Mount Bolts

Note: The number of bolts will be determined by desired mounting method.

Note: Bolts may be installed in top slot or bottom depending on desired mounting method.

Mounting Method Examples

This section illustrates a few of the methods of mounting the Marquee. By no means are these the only ways to mount the Marquee but are examples of how some customers have mounted the Marquee.

Chain Mount

Marquee mounting components needed:

- 4 mount attachment bolts
- 4 mount attachment nuts
- 2 hanger mounts

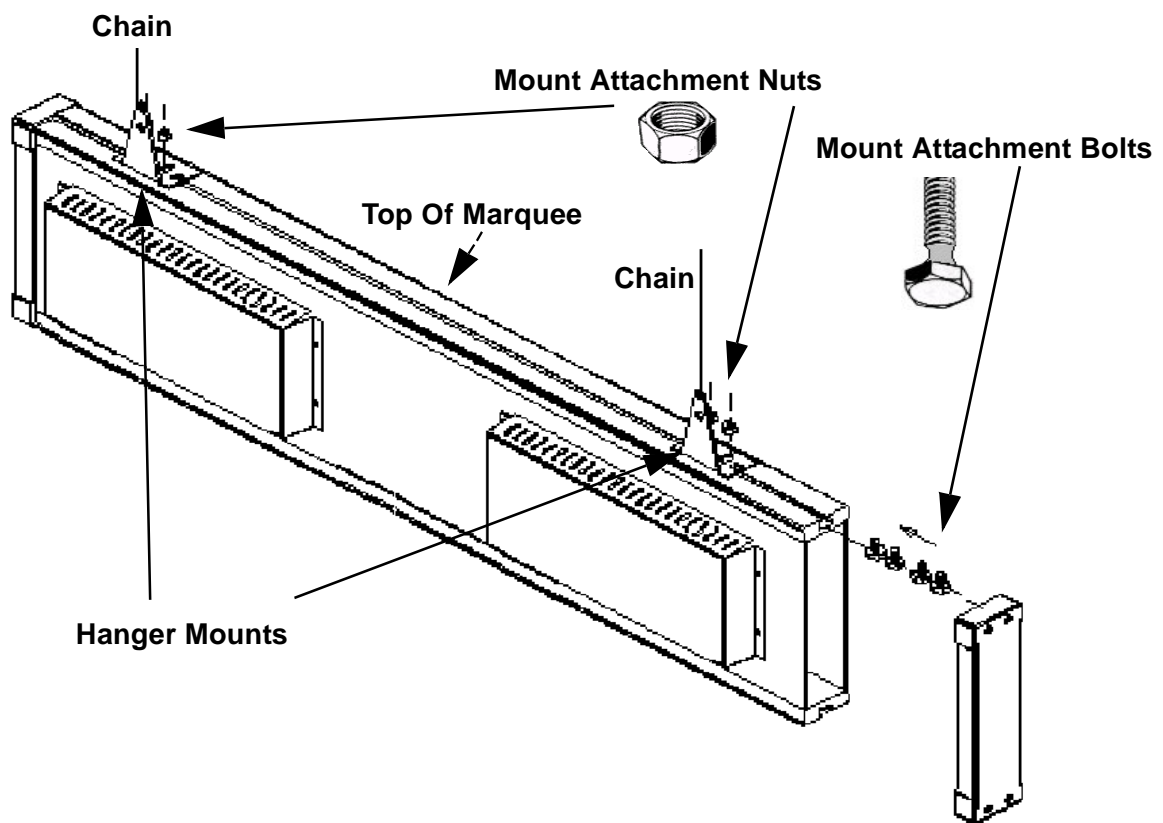

Figure 2—Chain Mount Example

Wall Mount With Swivel

Marquee mounting components needed:

- 4 mount attachment bolts
- 4 mount attachment nuts
- 2 hanger mounts
- 2 swivel mounts
- 4 mount interconnect bolts
- 4 mount interconnect nuts

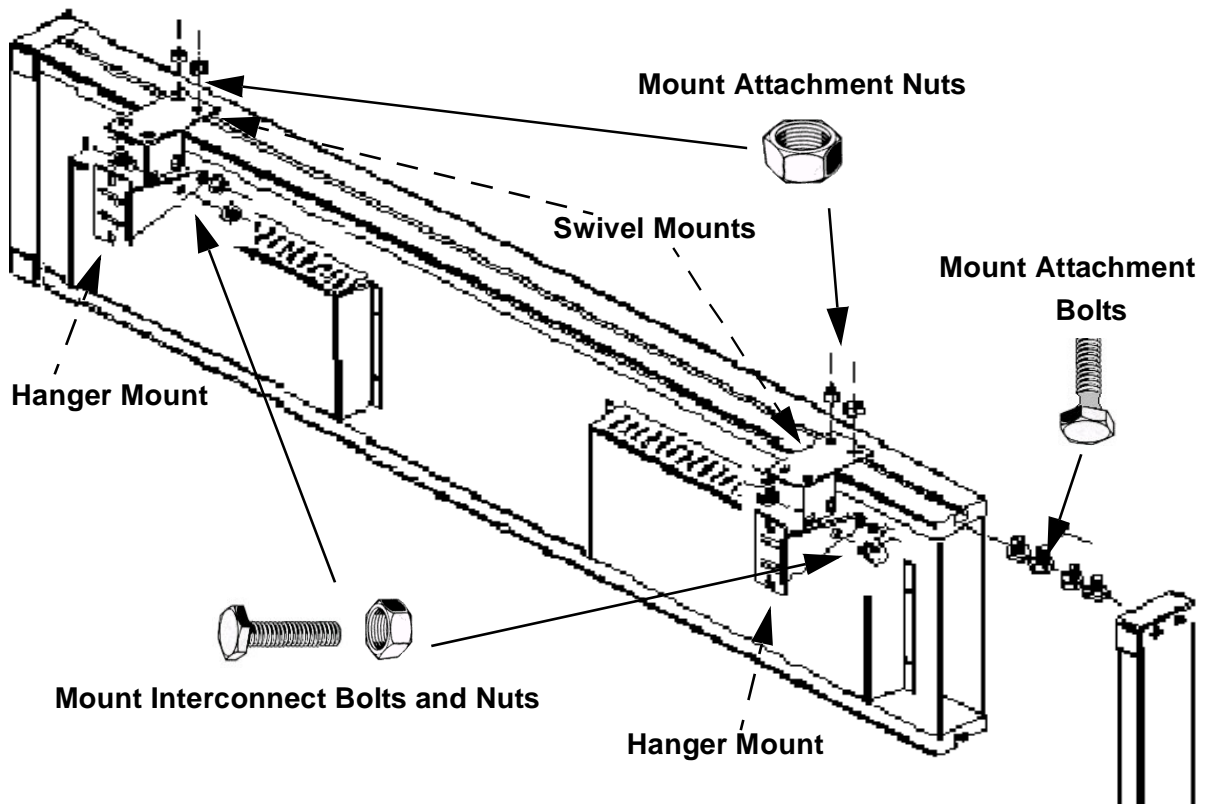

Figure 3—Wall Mount

Bottom Mount (8020 Front Mount)

Marquee mounting components needed:

- 4 mount attachment bolts
- 4 mount attachment nuts
- 2 hanger mounts

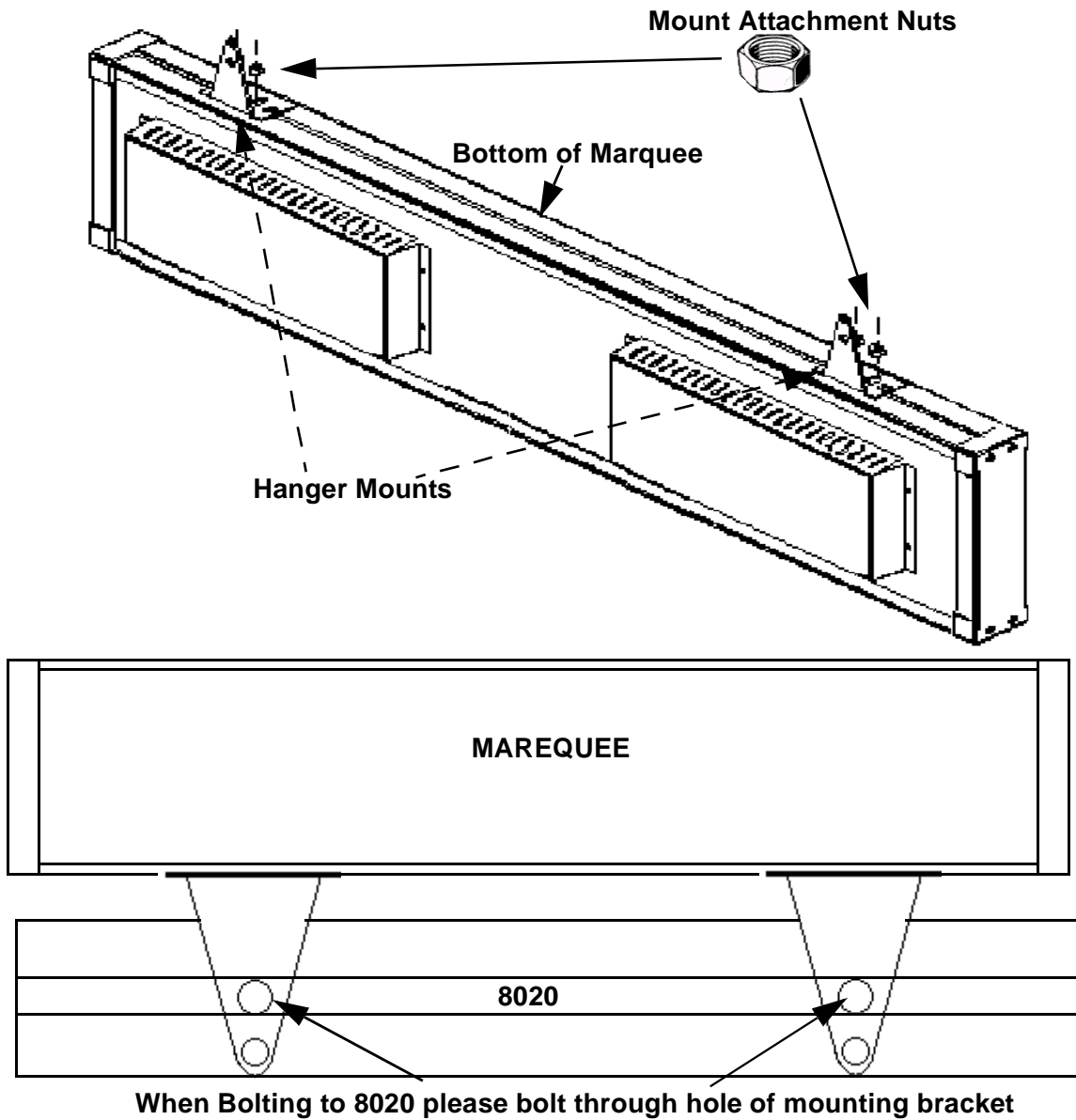

Figure 4—Bottom Mount

Bottom Mount (8020 top mount)

Marquee mounting components needed:

- 4 mount attachment bolts
- 4 mount attachment nuts
- 2 Swivel Mounts

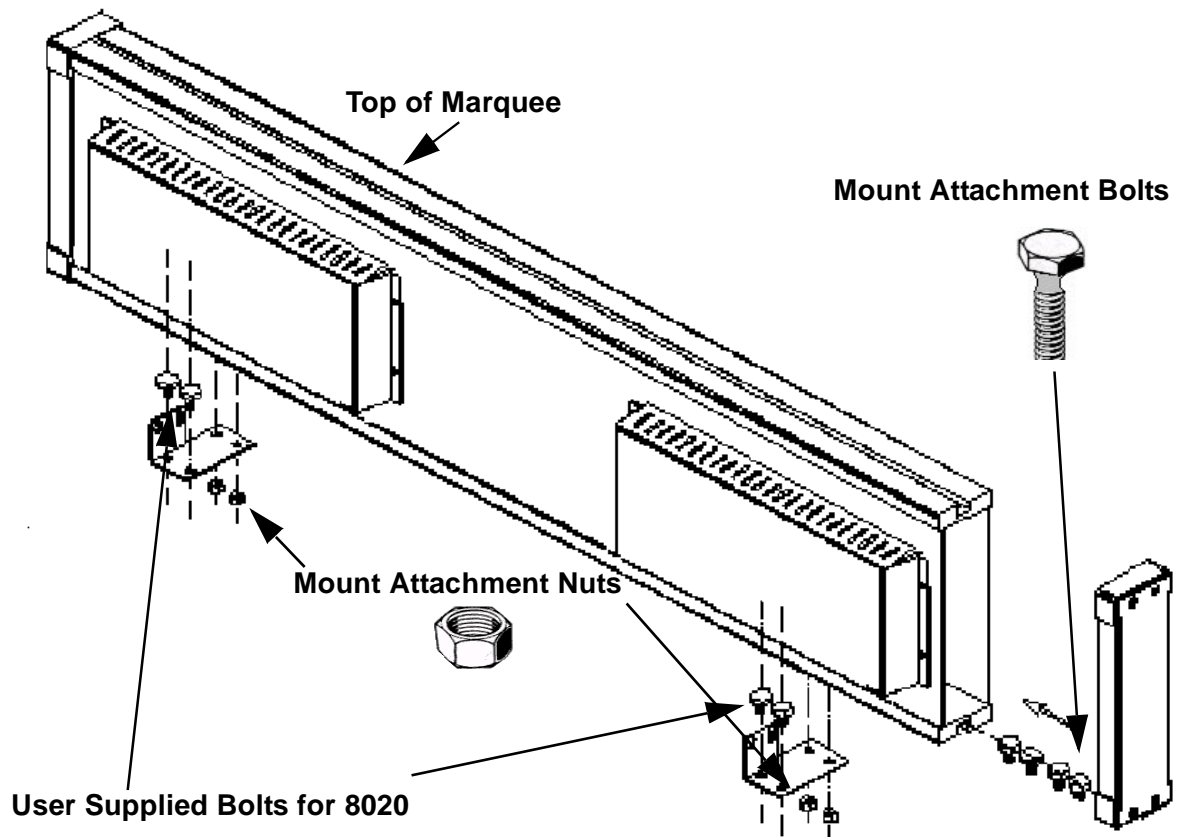

Figure 5—Bottom Mount