

Operation Manual

Model Number: IP-0XXX-T

V1.1

Copyright © 2006 DataVisor Marquees Inc.

Using The IR Remote	5
Key Usage Of IR Remote	6
The IR Menus Of The Marquee	7
Programming With The IR Remote	8
Entering Into Program Mode	8
Maneuvering Through Setup Menus	9
Setting Plant IP Address	10
Setting Plant SubNET Mask	11
Setting Plant Default Gateway	12
Setting Ethernet/IP IP Address	13
Setting Ethernet/IP Subnet Mask	14
Setting Time	15
Setting Date	16
Making The Plant Ethernet Connection	17
Quick Setup	18
Required Equipment	18
Steps To Connect The Marquee Via Ethernet	18
Detailed Ethernet Setup	20
Configuring the PC	20
Using IPCONFIG To Verify Ethernet Settings	24
Connecting The PC To The Marquee	26
Verifying Ethernet Communications	28
Connecting To the Marquee's WEB Server	31
Ethernet/IP Implementation	35
REQUIRE ETHERNET/IP MASTER/CLIENT	35
ETHERNET/IP CONNECTION	35
Ethernet/IP Specification	36
INPUT INSTANCE DATA MAP	37
OUTPUT INSTANCE DATA MAP	37
PLC Program Configuration Example	38
Marquee WEB Pages	41
MAIN PAGE	41
Access Configuration Pages	42
SETUP MENU	43
BACKUP AND RESTORE PAGE	44
EDIT MESSAGE	45
EDIT TEXT LIST	49
NETWORK SETTINGS	50
PLC COMMUNICATIONS SETTINGS	52
TIME/DATE SETUP	54
VARIABLE COLOR SETTINGS	57
VARIABLE DATA SETTINGS	58
Mounting Instructions	61
Mounting Hardware Included	61

Installing Mount Attachment Bolts	62
Mounting Method Examples	63
Specifications	67

—Chapter 1—

Using The IR Remote

This chapter will discuss the use of the IR remote. The remote is used to initially set the Network Parameters, Time and Date. It can also be used during operation to allow for resetting of process variables.

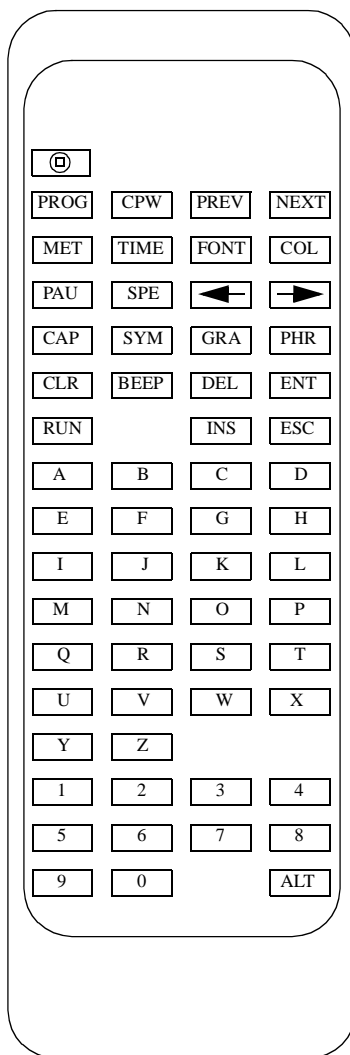

Key Usage Of IR Remote

There are many keys that are not currently used for the operation of the Marquee display. The following lists the keys that have operation capability with the marquee.

KEY	USAGE
PROG	Enter Program Mode
PREV	Go To Previous Program Screen
NEXT	Go To Next Program Screen
←	Move Cursor To Left
→	Move Cursor To Right
RUN	Return to Operating Mode
Y	Used For Conformation Of Change
N	Used for Rejection Of Change
0-9	Numeric Keys For Data Entry

Table 1—IR Remote Key Usage

The IR Menus Of The Marquee

The following are the menus that can be accessed via the IR remote. These menus allow the user to configure the basic settings of the Marquee display.

Note: On 1 Line units the ENT key must be pressed to access second line of menu.

Menu	Usage
<div style="border: 1px solid black; padding: 5px; text-align: center;"> PLANT IP ADDRESS 192.168.1.200 </div>	Allows the user to set the Ethernet IP address for the built in plant ethernet port of the Marquee.
<div style="border: 1px solid black; padding: 5px; text-align: center;"> PLANT NET MASK 255.255.255.000 </div>	Allows the user to set the Ethernet SUB NET MASK for the built in plant Ethernet port of the Marquee.
<div style="border: 1px solid black; padding: 5px; text-align: center;"> PLANT GATEWAY 000.000.000.000 </div>	Allows the user to set the Ethernet DEFAULT GATEWAY for the built in plant Ethernet port of the Marquee. Not present on 1 line units.
<div style="border: 1px solid black; padding: 5px; text-align: center;"> E/IP IP ADDRESS 192.168.1.200 </div>	Allows the user to set the Ethernet IP address for the Ethernet/IP port of the Marquee.
<div style="border: 1px solid black; padding: 5px; text-align: center;"> E/IP SUBNET MASK 255.255.255.000 </div>	Allows the user to set the Ethernet SUBNET Mask for the Ethernet/IP port of the Marquee.
<div style="border: 1px solid black; padding: 5px; text-align: center;"> SET TIME 02:47:37 </div>	Allows the user to set the TIME for the built in real time clock of the Marquee.
<div style="border: 1px solid black; padding: 5px; text-align: center;"> SET DATE 06/10/06 </div>	Allows the user to set the DATE for the built in real time clock of the Marquee.

Table 2—Marquee Configuration Menus

Programming With The IR Remote

The following section will describe the steps that are taking in order to enter program mode and accessing the Marquee setup menus. In this section the user will be instructed on how to accomplish the following tasks.

- Set the Ethernet parameters of the Marquee
- Set the Time and Date on the Marquee display

Entering Into Program Mode

In order to access the setup menus the user must put the Marquee into program mode. This is as simple as pressing the PROG key on the IR remote.

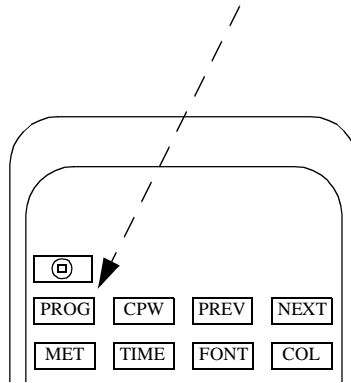

The follow message will be displayed on the Marquee.

PLANT IP ADDRESS
192.168.1.200

Note: The user should be within 20 Ft of the Marquee in order for IR operations!

Maneuvering Through Setup Menus

Once in program mode, the user uses the PREV and NEXT keys to scroll through the setup menus.

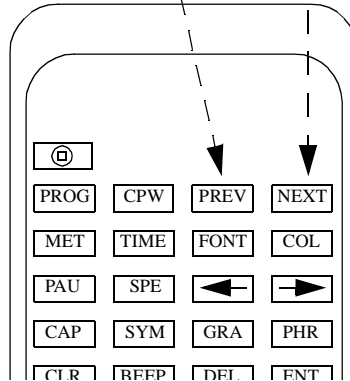

By using these keys the user can select the menu item that is desired and take appropriate action. The NEXT key takes the user to the next menu and the PREV key goes back to the previous menu. If the user is on the last menu item and presses the NEXT key the first menu item will be displayed. If the user is on the first menu item and presses the PREV key the last menu item will be displayed.

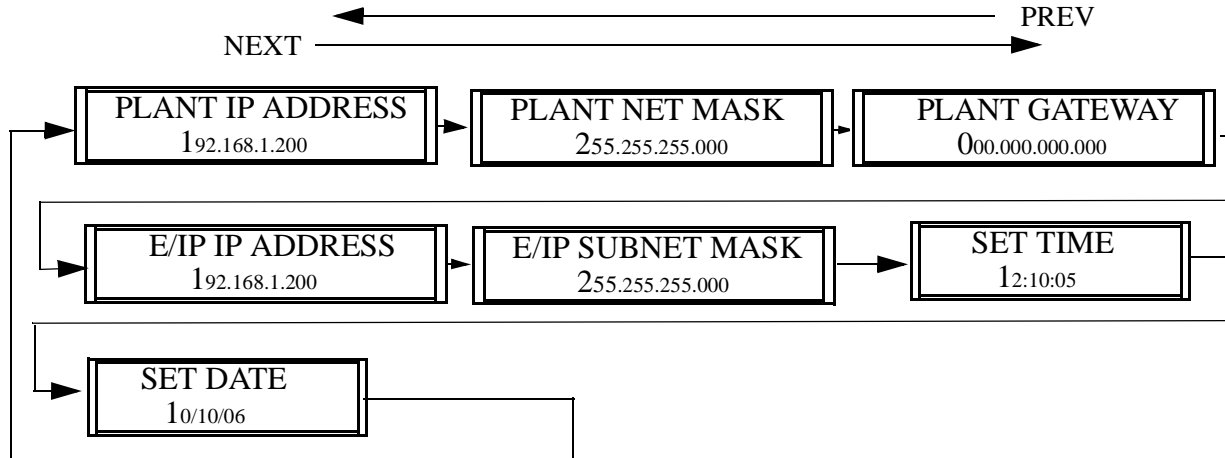

Note: On 1 line units the second line of the menu is accessed by pressing the ENT on the IR remote.

Setting Plant IP Address

The user can set the Ethernet IP address of the built in Ethernet port via the IR remote. Follow these steps to accomplish this task.

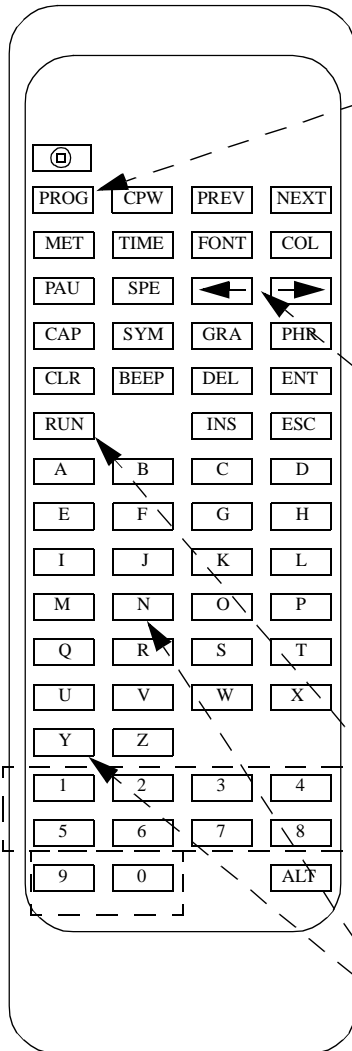

1. Press the PROG key to put Marquee into program mode.

2. The Following message will appear on the Marquee.

```

┌──────────────────┐
│  PLANT IP ADDRESS  │
│                    │
│  192.168.1.200    │
└──────────────────┘
    
```

3. The user should notice that the first digit within the IP address is larger than the rest. This indicates the cursor position.

4. The cursor position can be moved by pressing the → or the ← key of the remote. As you move the cursor the enlarged value will move across the Marquee to indicate current cursor position.

```

Example: 192.168.1.200 Press →
          192.168.1.200 Press ←
          192.168.1.200
    
```

5. Pressing any of the numeric keys will change the value of the current position to that value and move the cursor position to the right.

6. Once the proper IP address is displayed press the RUN key. The confirmation message will be displayed.

```

┌──────────────────┐
│  ACCEPT NEW IP    │
│  PRESS Y FOR YES  │
└──────────────────┘
    
```

7. At this point pressing the Y key will change the Marquee's IP address and return the Marquee to operating mode.

If the N key is pressed then the IP address will not be changed and the Marquee will return to operating mode.

Setting Plant SubNET Mask

The user can set the Ethernet SubNET Mask of the built in Ethernet port via the IR remote. Follow these steps to accomplish this task.

1. Press the PROG key to put Marquee into program mode.
2. The Following message will appear on the Marquee.

PLANT IP ADDRESS
 192.168.1.200
3. Press the NEXT key on the remote to go to the NET MASK menu item. The follow will be displayed.

PLANT NET MASK
 255.255.255.000
4. The user should notice that the first digit within the mask is larger than the rest. This indicates the cursor position.
5. The cursor position can be moved by pressing the → or the ← key of the remote. As you move the cursor the enlarged value will move across the Marquee to indicate current cursor position.

Example: 255.255.255.0 Press →

255.255.255.0 Press ←

255.255.255.0
6. Pressing any of the numeric keys will change the value of the current position to that value and move the cursor position to the right.
7. Once the proper SubNet Mask is displayed press the RUN key. The confirmation message will be displayed.

ACCEPT NEW IP
 PRESS Y FOR YES
8. At this point pressing the Y key will change the Marquees Subnet Mask and return the Marquee to operating mode. If the N key is pressed then the Subnet Mask will not be changed and the Marquee will return to operating mode.

Setting Plant Default Gateway

The user can set the Ethernet Default Gateway of the built in Ethernet port via the IR remote. Follow these steps to accomplish this task.

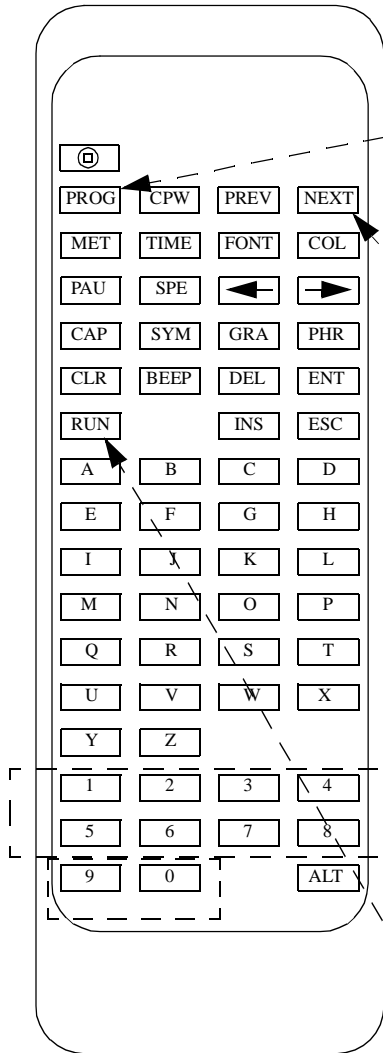

1. Press the PROG key to put Marquee into program mode.

2. The Following message will appear on the Marquee.

```

┌──────────────────┐
│  PLANT IP ADDRESS  │
│          192.168.1.200          │
└──────────────────┘
    
```

3. Press the NEXT key two times on the remote to go to the GATEWAY menu item. The follow will be displayed.

```

┌──────────────────┐
│  PLANT GATEWAY     │
│  ──▶000.000.000.000│
└──────────────────┘
    
```

4. The user should notice that the first digit within the gateway is larger than the rest. This indicates the cursor position.

5. The cursor position can be moved by pressing the \rightarrow or the \leftarrow key of the remote. As you move the cursor the enlarged value will move across the Marquee to indicate current cursor position.

```

Example: 255.255.255.0 Press ──▶
          255.255.255.0 Press ◀──
          255.255.255.0
    
```

6. Pressing any of the numeric keys will change the value of the current position to that value and move the cursor position to the right.

7. Once the proper GATEWAY is displayed press the RUN key. The confirmation message will be displayed.

```

┌──────────────────┐
│  ACCEPT NEW IP    │
│  PRESS Y FOR YES  │
└──────────────────┘
    
```

8. At this point pressing the Y key will change the Marquee's Gateway and return the Marquee to operating mode. If the N key is pressed then the Gateway will not be changed and the Marquee will return to operating mode.

Setting Ethernet/IP IP Address

The user can set the Ethernet/IP IP Address of the built in Ethernet/IP port via the IR remote. Follow these steps to accomplish this task.

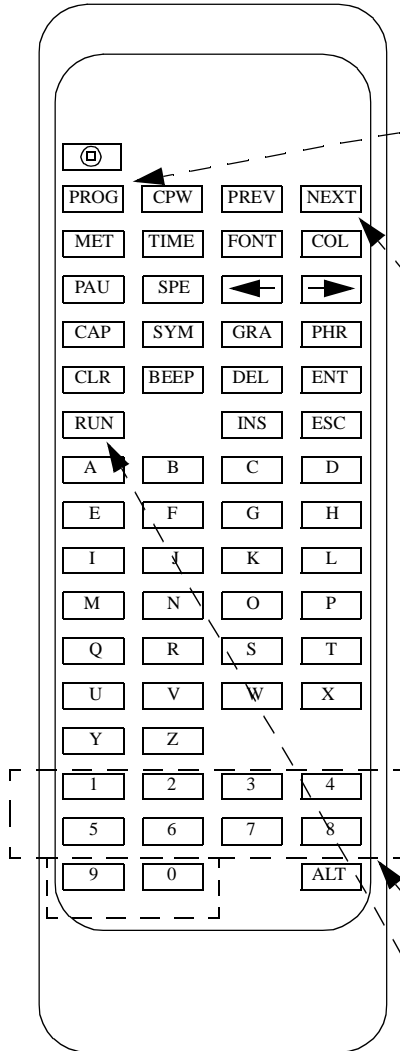

1. Press the PROG key to put Marquee into program mode.

2. The Following message will appear on the Marquee.

```

  PLANT IP ADDRESS
  192.168.1.200
  
```

3. Press the NEXT key three times on the remote to go to the E/IP IP ADDRESS menu item. The follow will be displayed.

```

  E/IP IP ADDRESS
  →192.168.1.200
  
```

4. The user should notice that the first digit within the E/IP Address larger than the rest. This indicates the cursor position.

5. The cursor position can be moved by pressing the → or the ← key of the remote. As you move the cursor the enlarged value will move across the Marquee to indicate current cursor position.

```

  Example: 255.255.255.0 Press →
           255.255.255.0 Press ←
           255.255.255.0
  
```

6. Pressing any of the numeric keys will change the value of the current position to that value and move the cursor position to the right.

7. Once the proper IP address is displayed press the RUN key. The confirmation message will be displayed.

```

  ACCEPT NEW IP
  PRESS Y FOR YES
  
```

8. At this point pressing the Y key will change the Marquee Gateway and return the Marquee to operating mode.
If the N key is pressed then the Gateway will not be changed and the Marquee will return to operating mode.

Setting Ethernet/IP Subnet Mask

The user can set the Ethernet/IP IP Address of the built in Ethernet/IP port via the IR remote. Follow these steps to accomplish this task.

1. Press the PROG key to put Marquee into program mode.
2. The Following message will appear on the Marquee.

PLANT IP ADDRESS
192.168.1.200
3. Press the NEXT key four times on the remote to go to the E/IP SUBNET MASK menu item. The follow will be display

E/IP SUBNET MASK
255.255.255.000
4. The user should notice that the first digit within the E/IP Address larger than the rest. This indicates the cursor position.
5. The cursor position can be moved by pressing the → or the ← key of the remote. As you move the cursor the enlarged value will move across the Marquee to indicate current cursor position.

Example: 255.255.255.0 Press →

255.255.255.0 Press ←

255.255.255.0
6. Pressing any of the numeric keys will change the value of the current position to that value and move the cursor position to the right.
7. Once the proper Subnet Mask is displayed press the RUN key. The confirmation message will be displayed.

ACCEPT NEW IP
PRESS Y FOR YES
8. At this point pressing the Y key will change the Marquees Gateway and return the Marquee to operating mode.
If the N key is pressed then the Gateway will not be changed and the Marquee will return to operating mode.

Setting Time

The user can set the time of the built in real time clock via the IR remote. Follow these steps to accomplish this task.

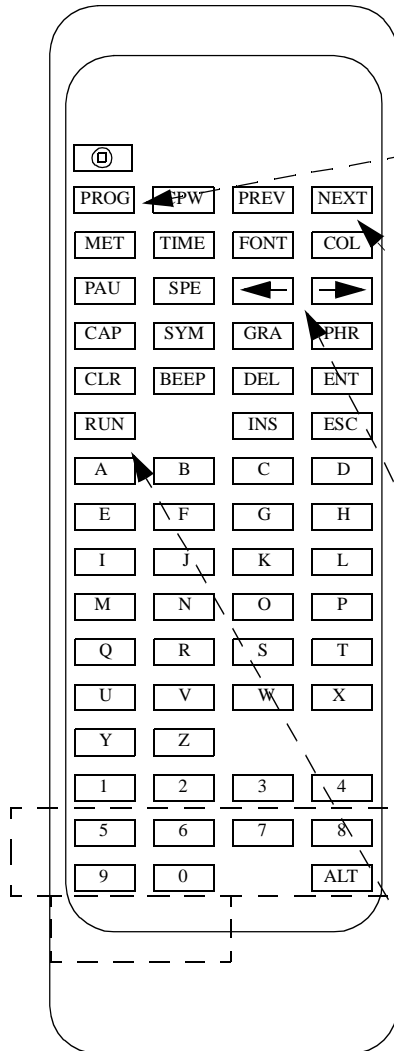

1. Press the PROG key to put Marquee into program mode.

2. The Following message will appear on the Marquee.

```

IP ADDRESS
192.168.1.200
  
```

3. Press the NEXT key five times on the remote to go to the SET TIME menu item. The follow will be displayed.

```

SET TIME
12:10:05
  
```

4. The user should notice that the first digit within the time is larger than the rest. This indicates the cursor position.

5. The cursor position can be moved by pressing the \rightarrow or the \leftarrow key of the remote. As you move the cursor the enlarged value will move across the Marquee to indicate current cursor position.

```

Example: 12:10:05   Press  $\rightarrow$ 
           12:10:05   Press  $\leftarrow$ 
           12:10:05
  
```

6. Pressing any of the numeric keys will change the value of the current position to that value and move the cursor position to the right.

7. Once the proper Time is displayed press the RUN key which set the new time and put the Marquee into operating mode.

Setting Date

The user can set the date of the built in real time clock via the IR remote. Follow these steps to accomplish this task.

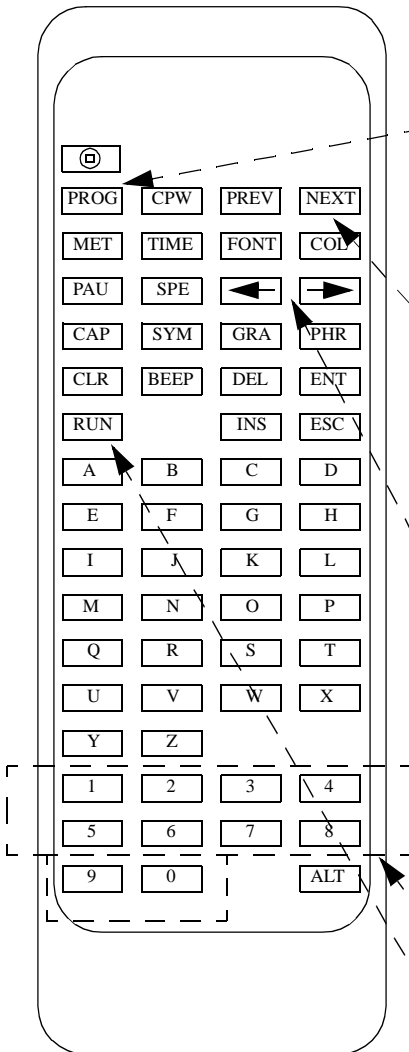

1. Press the PROG key to put Marquee into program mode.

2. The Following message will appear on the Marquee.

```

IP ADDRESS
192.168.1.200
    
```

3. Press the NEXT key six times on the remote to go to the SET TIME menu item. The follow will be displayed.

```

SET DATE
10/10/06
    
```

4. The user should notice that the first digit within the date is larger than the rest. This indicates the cursor position.

5. The cursor position can be moved by pressing the → or the ← key of the remote. As you move the cursor the enlarged value will move across the Marquee to indicate current cursor position.

```

Example: 10/10/06   Press →
           10/10/06   Press ←
           10/10/06
    
```

6. Pressing any of the numeric keys will change the value of the current position to that value and move the cursor position to the right.

7. Once the proper Time is displayed press the RUN key which set the new date and put the Marquee into operating mode.

Making The Plant Ethernet Connection

This chapter describes the steps that are taken in order to connect the Marquee to a Plant ethernet network or configuration PC to allow the configuration of the Marquee.

The IP-0xxx-T has two ethernet ports. A plant ethernet port, which is accessed through the RJ45 connector on the side of the Marquee, and an Ethernet/IP Ethernet port which is accessed via the EIP port on the bottom of the Marquee.

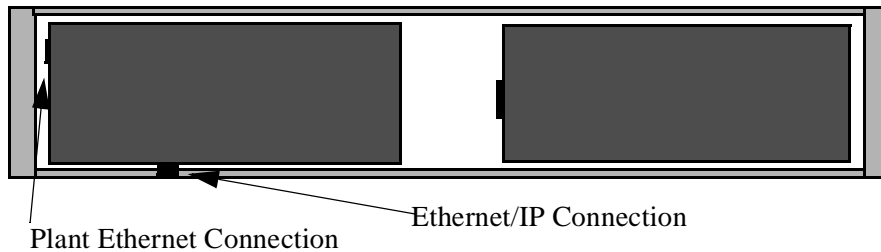

The Plant Ethernet port is used for configuration, monitoring and data collection from the Marquee. The EIP port is used to connect the Marquee to a Ethernet/IP master/client device. The Marquee operates as an I/O server on the Ethernet/IP network, allowing any client that supports an I/O connection type 1 to control the message being displayed and the data that may be embedded within that message.

In most cases, the first step in configuring the Marquee is physically connecting the Marquee to what is known as a configuration PC. A configuration PC can be a laptop or desk-top PC that is equipped with an ethernet port and has WEB browser software installed. There are many different WEB browsers available on the market today. Please refer to the documentation for WEB browser that is being used if it is unclear what is needed to be accomplished.

The Marquee can be connected directly to a PC's ethernet port or connected to the facility network. It is recommended that the first time a user connects directly to the Marquee and does not connect to the facility network. By connecting directly, the user has more control over the ethernet network settings and the need to consult with the IT department or network administrator of the facility is not required.

Note: Prior to connecting to the facility network, it is highly recommended to consult the facility IT department or the network administrator of the facility.

Quick Setup

This section is designed for the user who is familiar with connecting devices via ethernet. This section assumes a direct connection between the ethernet port of a PC and the Ethernet port of the Marquee.

If the user is not familiar with connecting ethernet devices or configuring ethernet Parameters of the PC it is highly recommended to go to the section *Detailed Ethernet Setup* section.

Required Equipment

- DataVisor Marquee
 - PC with Ethernet port and a Web browser installed
- Note:** The user must have administrator rights on the PC
- An Ethernet cross cable or a switch with an Ethernet patch cable.

Steps To Connect The Marquee Via Ethernet

These steps use the factory default ethernet parameters that are set in the Marquee.

- IP Address 192.168.1.200
- Subnet Mask 255.255.255.0

1. Connect a ethernet cross-over cable between the PC and the Marquee

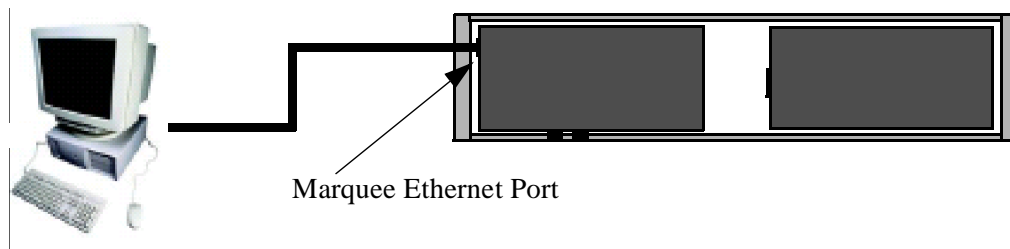

2. Apply power to the Marquee

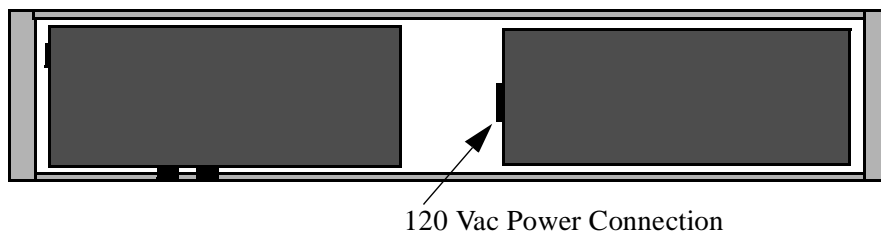

3. Power the PC
4. Configure the PC's ethernet port.
 - IP address 192.168.1.100
 - SubNet Mask 255.255.255.

Note: Refer to the section *Set the PC for Fixed IP Address* for detailed instructions.

4. Start the WEB browser application and enter the IP address of the Marquee in the address field.
In the address bar type **http://192.168.1.200** then press the ENTER key

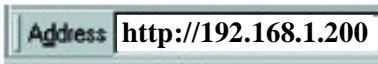

Note: On many browsers the **http://** is automatically added to the address so the user does not need to type it in.

6. At this point the MONITOR page of the Marquee should be displayed in Internet Explorer

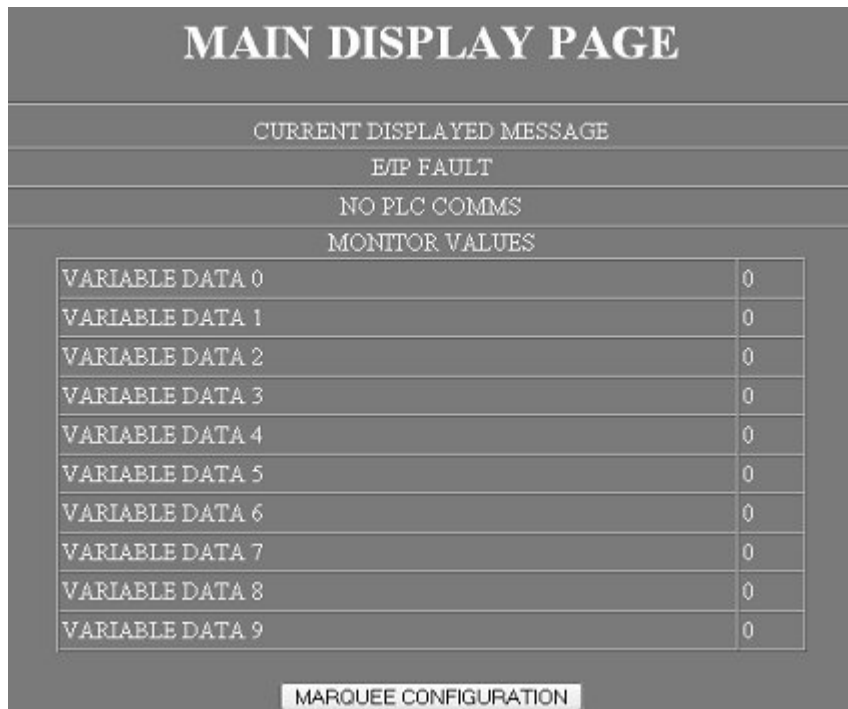

7. The user may now access the configuration WEB pages of the Marquee.

Note: Please refer to the section *Marquee Configuration Pages* for details on the configuration pages.

If the user has problems accessing the Marquee's WEB pages, please follow the detailed steps in the following section.

Detailed Ethernet Setup

This section describes in detail the steps to establish an ethernet connection to the Marquee in order to configure it's operation. This section assumes the user will be using the default ethernet settings of the Marquee. If the user changes the default ethernet settings, such as the IP address, the user must use the new settings in place of the defaults when referenced in this section.

- Default IP address of Marquee 192.168.1.200
- Default SubNet Mask of Marquee 255.255.255.0
- Default Gateway of Marquee 0.0.0.0

This section is for connecting the Marquee directly to the PC. If the user wishes to connect the Marquee to the facility network, it is highly advised that the network administrator or IT department is involved. This is suggested so as the Ethernet network parameters of the Marquee can be configured to match the facility network parameters.

Configuring the PC

The first step in making an Ethernet connection to the Marquee is to configure the PC so as the Ethernet port of the PC can communicate to the Marquee. After the PC has been powered up follow these steps to verify the configuration of the PC.

Note: Prior to making changes to the ethernet configuration of the PC the existing configuration should be documented. The user may be required to revert back to the existing configuration in order to connect to the facility network.

Set the PC for a Fixed IP Address WINDOWS XP

Many facility networks in use today use what is known as DHCP to allow a server on the network to assign ethernet parameters to the PCs that are connected to the network. When connecting directly from the PC to another ethernet device such as the Marquee, the user must assign the Ethernet parameters of the PC manually.

Step 1

On the PC, click on START followed by CONTROL PANEL.

Note: Depending on the operation system of the PC the user may need to select SETTINGS in order to access the CONTROL PANEL.

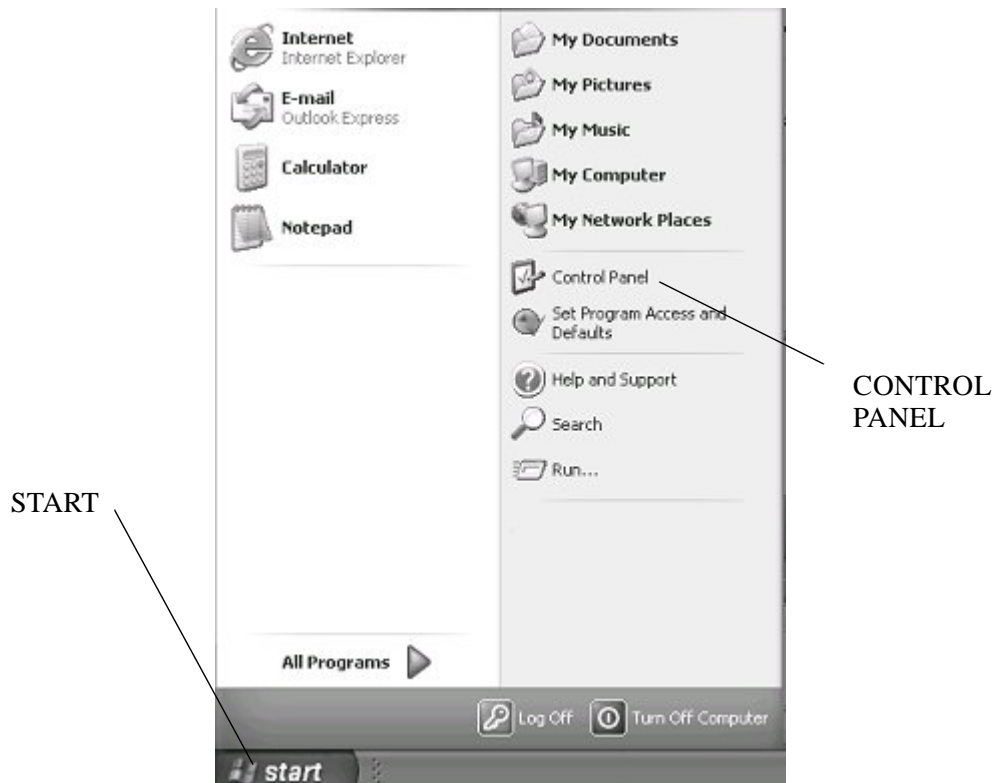

Step 2

In Control Panel double click on NETWORK CONNECTIONS.



Making The Plant Ethernet Connection

Detailed Ethernet Setup

Step 3

Under NETWORK CONNECTIONS find the Icon that says LOCAL AREA NETWORK. Then double click on this ICON. This allows the user to configuration the PC's ethernet port.



Step 4

One of two screens will be displayed. If the screen 1 is displayed, click the PROPERTIES button and screen 2 will be displayed.

SCREEN TYPE 1

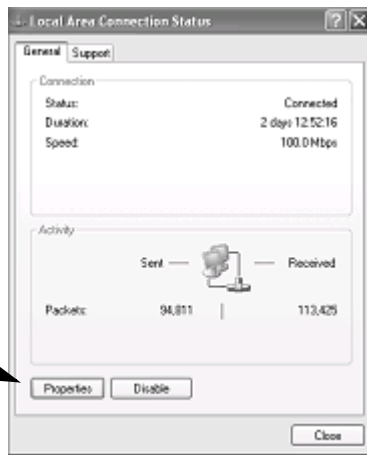

Properties Button

SCREEN TYPE 2



STEP 5

Select selection INTERNET PROTOCOL (TCP/IP) in the THIS CONNECTION USES THE FOLLOWING ITEMS box. Then click the PROPERTIES button.

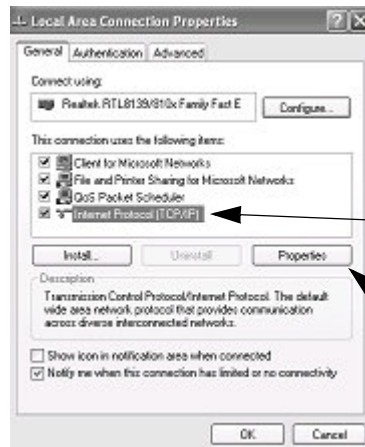

SELECT THIS ENTRY

PROPERTIES BUTTON

STEP 6

The properties for the TCP/IP communications is displayed. If the window looks like the screen below then the PC is set for connecting to as DHCP server. This means that the PC's ethernet parameters are generated by a DHCP server on the facility network. In order to make a direct connection to the Marquee the user must manually enter the Ethernet parameters. To accomplish this first select the item USE THE FOLLOWING IP ADDRESS. At this point the user will enter the IP address 192.168.1.100 and the SubNet Mask of 255.255.255.0.

After entry is completed click the OK button on each of the Network windows. This will cause the PC to accept the changes and reconfigure the local Ethernet port.

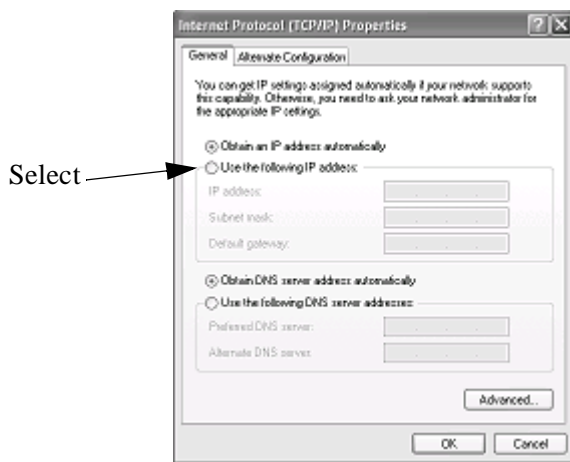

Enter IP address
and Subnet Mask

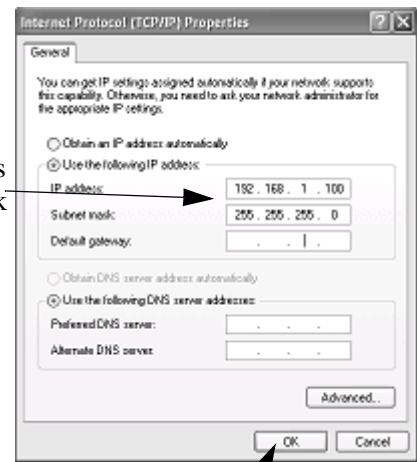

Click OK

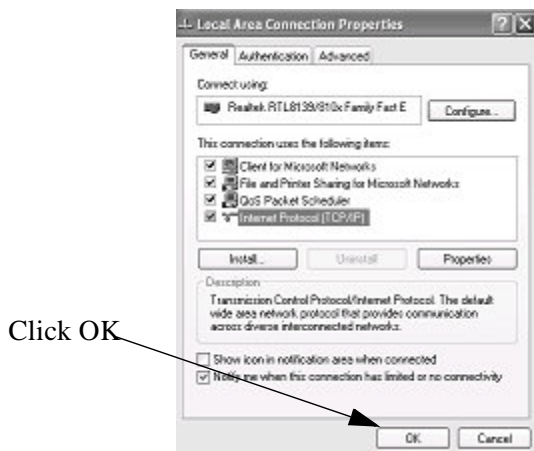

Click Close

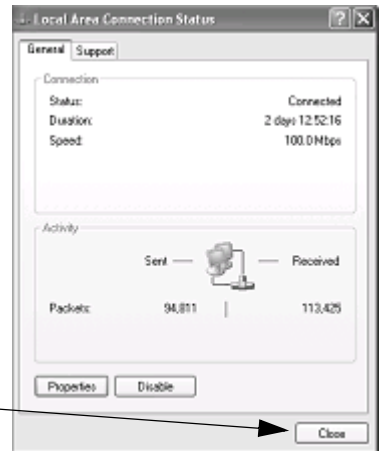

NOTE: THIS SCREEN MAY NOT BE DISPLAYED

Using IPCONFIG To Verify Ethernet Settings

This section is used to verify that the local Ethernet port of the PC is configured properly. In this section a detail description of the use of the IPCONFIG utility is demonstrated.

STEP 1

From the START menu click on the RUN operation.



STEP 2

The RUN command entry box will appear. Enter CMD into the open field of this window then click the OK Button. This will allow the user access to the command line entry prompt of WINDOWS.

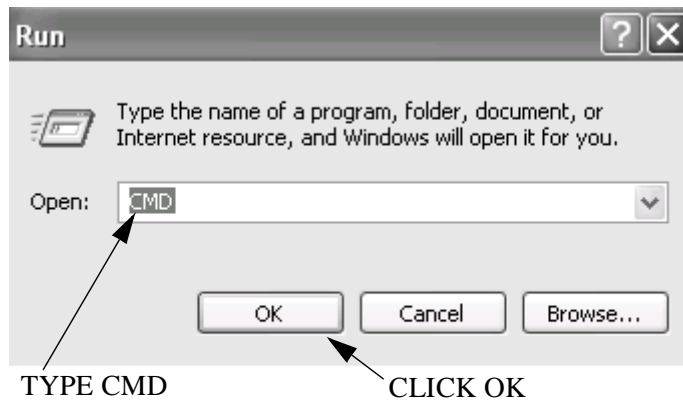

STEP 3

At this point the command line entry is displayed. At the Command Prompt type IPCONFIG and then press the ENTER key of the keyboard.

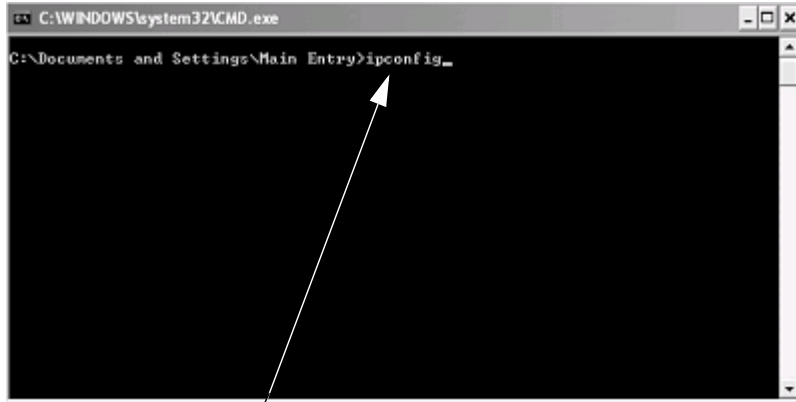

Type IPCONFIG then press the ENTER key

The Ethernet parameters of the PC's Ethernet port will be displayed. Verify that the IP address and Subnet mask match the entries previously entered. If the parameters do not match type:

- Verify that the parameters were entered correctly in the Network Properties window from the previous procedure.
- Reboot the PC and repeat this procedure.

Note: If the user is unable to successfully set the Ethernet parameters please consult the facility IT department or network administrator.

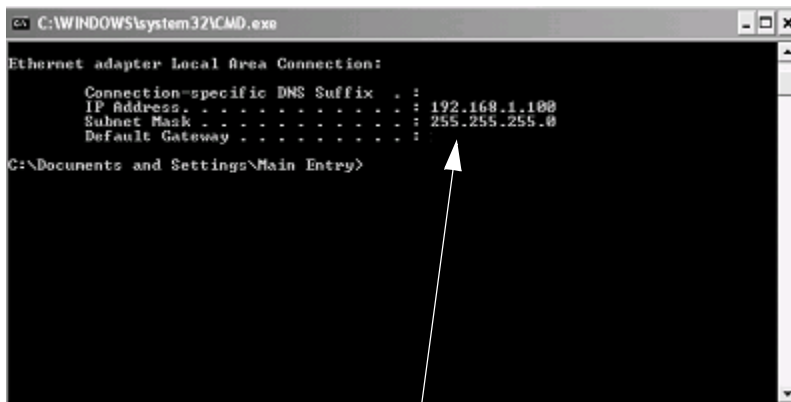

Ethernet Parameters for Local Port

Connecting The PC To The Marquee

Cable Description

This section discussing the steps to connect the Marquee directly to the PC.

There are two types of Ethernet cables available in today's market.

A patch or straight cable is used when connecting an Ethernet device to a Switch or HUB.

A Cross Over cable is used when connecting one Ethernet Device, such as a PC, to another Ethernet Device, such as the Marquee, without a HUB or Switch. This is known as a direct connection and requires that the Ethernet cable crosses the Ethernet signals. A Cross Over cable is included with the Marquee for this purpose. If the user is connecting the Marquee to a HUB or Switch, the user must supply the Patch or Straight Through cable.

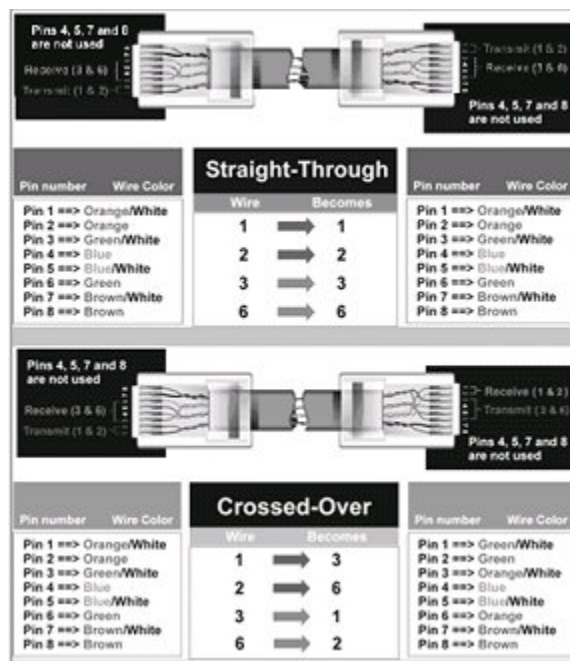
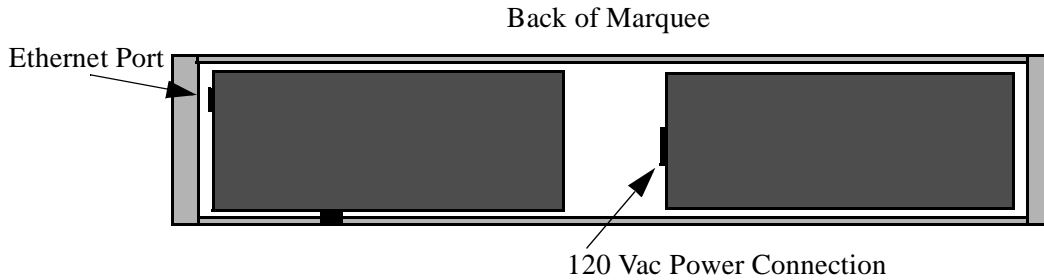

Figure 1—Ethernet Cable Pinouts

Connecting the Ethernet Cable

Prior to connecting the Marquee to the PC, both the PC and Marquee should be powered down.

Connect the Cross cable to the Ethernet port of the marquee. The Ethernet port is located on the right side of the Marquee.



Connect the other end of the Cross cable to the PC's Ethernet Port.

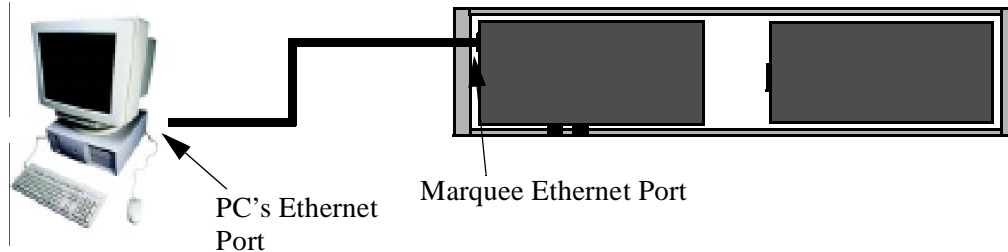

Power up both the PC and Marquee. After the PC has booted the user should check that the LINK light of the PC's Ethernet port is lit. The LINK light is lit when a physical connection is made between the PC's ethernet port and another Ethernet device, such as the Marquee. If the LINK light is lit then the PC is properly connected to the Marquee.

If the LINK light is not lit check the following:

- Verify the Marquee is powered
- Verify the cable is a cross over cable
- Verify the Ethernet port of the PC is Enabled

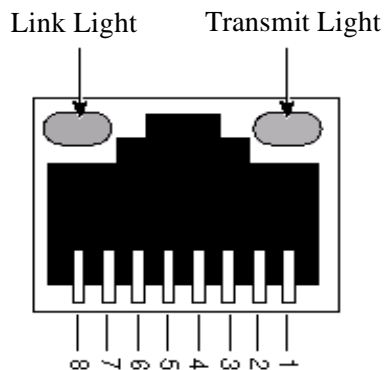

Verifying Ethernet Communications

The previous section verified the physical connection between the Ethernet port of the PC and the Marquee. This section will be used to verify a communication connection exists between the Marquee and the PC.

In order to communicate to the Marquee a communication connection must be established. The physical connection indicates that communication can physically occur but does not verify that the Ethernet parameters match between the Marquee and the PC. This section is used to verify the Ethernet Parameters of both the PC and Marquee.

STEP 1

On the PC, click START followed by RUN.



STEP 2

The RUN command entry box will appear. Enter CMD into the open field of this window then click the OK Button. This will allow the user access to the command line entry prompt of WINDOWS.

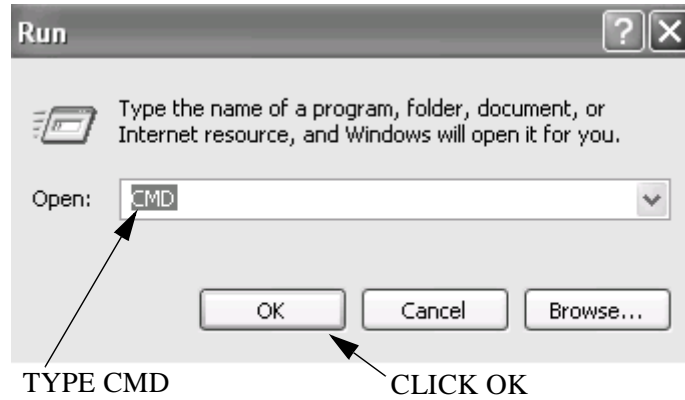

STEP 3

At this point the command line entry is displayed. At the Command Prompt type PING 192.168.1.200 and then press the ENTER key of the keyboard. This operation sends a low level command to verify that communications can be established. The following screen shots display the three different responses that may occur during this operation along with the description of the response.

Reply From

This is an indication that Ethernet communication is established to the Marquee. Proceed to next section.

```
C:\WINDOWS\system32\CMD.exe

C:\Documents and Settings\Main Entry>ping 192.168.1.200
Pinging 192.168.1.200 with 32 bytes of data:
Reply from 192.168.1.200: bytes=32 time=1ms TTL=150
Reply from 192.168.1.200: bytes=32 time<1ms TTL=150
Reply from 192.168.1.200: bytes=32 time<1ms TTL=150
Reply from 192.168.1.200: bytes=32 time<1ms TTL=150
Ping statistics for 192.168.1.200:
    Packets: Sent = 4, Received = 4, Lost = 0 (0% loss),
    Approximate round trip times in milli-seconds:
        Minimum = 0ms, Maximum = 1ms, Average = 0ms
C:\Documents and Settings\Main Entry>_
```

Request timed out

This indicates that the connection to the Marquee could not be established.

- Verify the IP address and Subnet Mask are correct on the Marquee
- Verify cabling and LINK light is lit
- Verify Ethernet settings of PC



```
C:\WINDOWS\system32\CMD.exe
C:\Documents and Settings\Main Entry>ping 192.168.1.200
Pinging 192.168.1.200 with 32 bytes of data:
Request timed out.
Request timed out.
Request timed out.
Request timed out.
Ping statistics for 192.168.1.200:
    Packets: Sent = 4, Received = 0, Lost = 4 (100% loss),
C:\Documents and Settings\Main Entry>
```

Response

Destination Host Unreachable

This is an indication that the PC's Ethernet settings are not correct. This is a common error when the IP address or Subnet mask is set incorrectly.

- Verify the PC's Ethernet settings
- Reboot pc

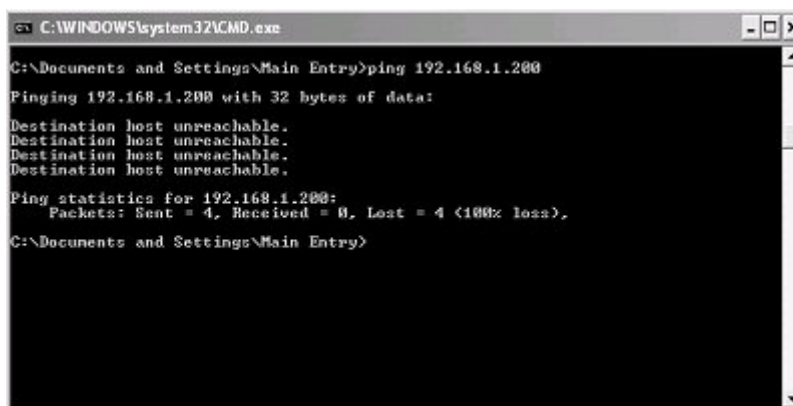

```
C:\WINDOWS\system32\CMD.exe
C:\Documents and Settings\Main Entry>ping 192.168.1.200
Pinging 192.168.1.200 with 32 bytes of data:
Destination host unreachable.
Destination host unreachable.
Destination host unreachable.
Destination host unreachable.
Ping statistics for 192.168.1.200:
    Packets: Sent = 4, Received = 0, Lost = 4 (100% loss),
C:\Documents and Settings\Main Entry>
```

Connecting To the Marquee's WEB Server

In this section a detailed explanation of the steps that are used to access the built in WEB sever of the Marquee are discussed.

There are many different WEB browser software packages available on the market today. In this section a general overview of WEB browser settings are discussed. Most WEB browsers support the settings discussed in this section. The user should reference documentation specific to the WEB browser that is being used to determine how settings are configured within a given WEB browser.

Note: In most cases no setting changes are required to the WEB browser. Only in specific cases is this required.

Step 1

Start the WEB Browser on the PC.

Step 2

In the Address Bar type HTTP://192.168.1.200.

Note: 192.168.1.200 is the default IP address of the Marquee. If this has been changed by the user, change the IP address to match the IP address of the Marquee.

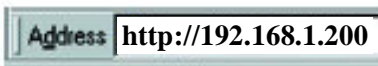

Note: On many browsers the **http://** is automatically added to the address so the user does not need to type it in.

Step 3

At this point one of two items will be displayed in the WEB Browser.

Marquee's Monitor Screen Appears

This is an indication that the WEB browser has established a connection to the Marquee's WEB server. The user can now proceed to configure the Marquee.

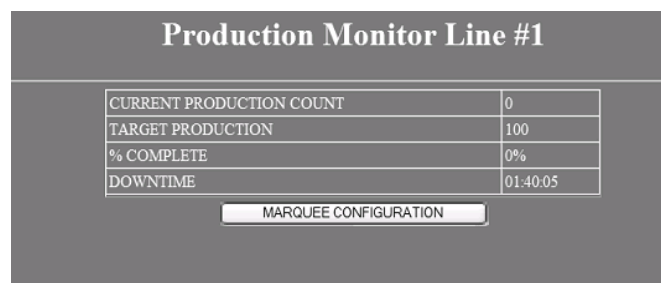
A screenshot of a web browser displaying a 'Production Monitor Line #1' screen. The screen has a dark grey background with white text. At the top, it says 'Production Monitor Line #1'. Below that is a table with four rows: 'CURRENT PRODUCTION COUNT' (0), 'TARGET PRODUCTION' (100), '% COMPLETE' (0%), and 'DOWNTIME' (01:40:05). At the bottom of the screen is a button labeled 'MARQUEE CONFIGURATION'.

Production Monitor Line #1	
CURRENT PRODUCTION COUNT	0
TARGET PRODUCTION	100
% COMPLETE	0%
DOWNTIME	01:40:05

MARQUEE CONFIGURATION

No Monitor Page is Displayed

The Monitor page is not displayed and a message such as WEB PAGE CAN NOT BE LOADED or FOUND. This error can be caused by the WEB browser's settings not being configured properly. The most common reasons for this error are listed below.

Note: It is assumed the user has followed the proceeding sections to verify Ethernet communication to the Marquee. If not please refer to these sections to verify that the Ethernet settings of the PC are correct.

WEB browser using wrong Ethernet Connection

In many PCs, such as a laptop, more than one Ethernet connection exists. In many cases a wireless Ethernet connection exist on the PC and because of this the WEB browser uses this connection as the default Ethernet Connection.

The solution for this is to DISABLE all Ethernet connections except the LOCAL Ethernet port.

STEP 1

Click on START followed by Control Panel.

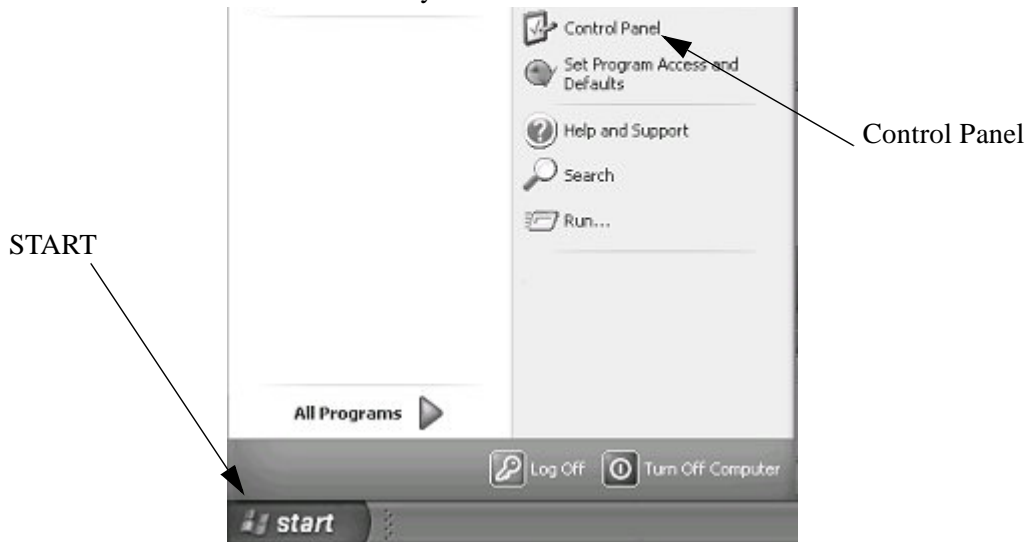

STEP 2

Click on NETWORK CONNECTIONS.



STEP 3

Right click on each Network connection other than the LOCAL CONNECTION and select DISABLE.

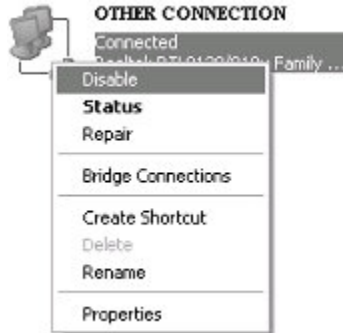

STEP 4

Restart PC and then restart the WEB browser.

WEB Browser Using Proxy server

In many facility networks, the WEB browser does not make a direct connection to the Internet. In these cases a PROXY server is connected to the network and the WEB server connects to this PROXY server to access WEB pages. When directly connecting to a WEB server, such as the Marquee, this setting within the WEB browser must be turned off. Follow these steps to disable the PROXY server.

STEP 1

Open the WEB browser.

STEP 2

Within the WEB browser select TOOLS followed by INTERNET OPTIONS

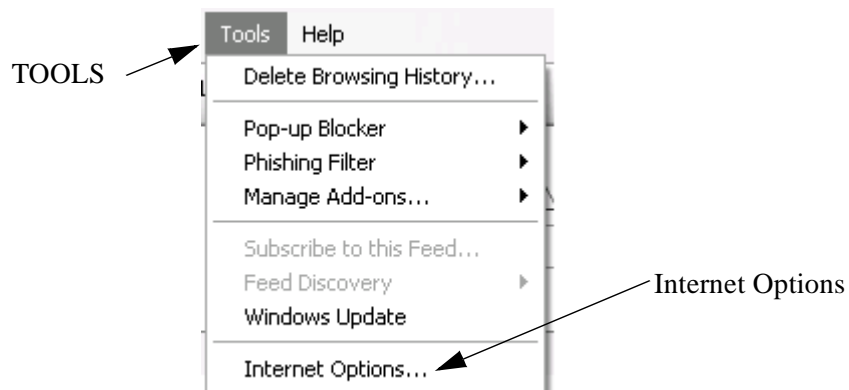

Making The Plant Ethernet Connection

Detailed Ethernet Setup

STEP 3

The following screen will be displayed. Select the CONNECTIONS TAB. Followed by clicking on LAN SETTINGS.

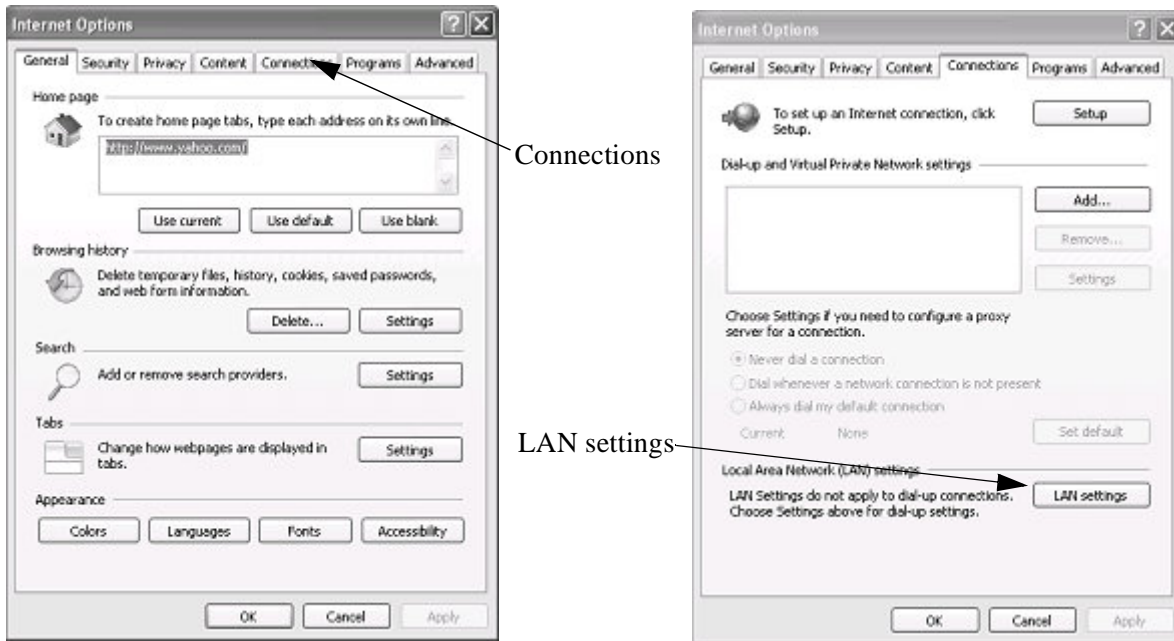

STEP 4

IF selected, deselect PROXY SERVER. Click OK on all windows and restart the WEB BROWSER.

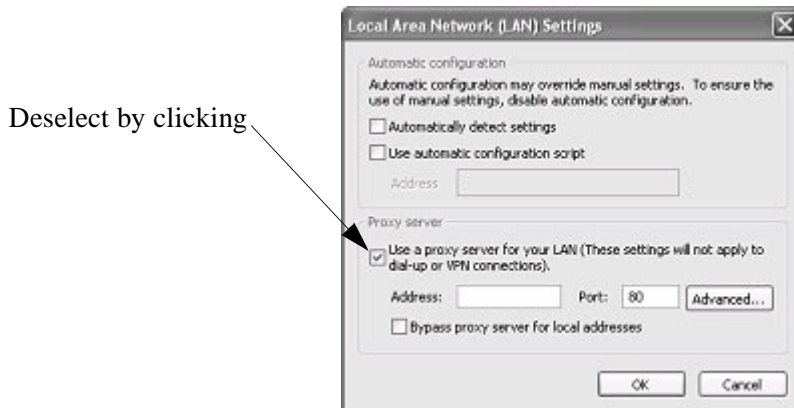

Ethernet/IP Implementation

The IP-0XXX-T series of Marquees have been designed to work on Ethernet/IP as a Generic Ethernet I/O module. No special Message Blocks or other special programming is required within the controller to control the Marquee. This chapter will discuss the Ethernet/IP implementation and how to configure the Marquee on an Ethernet/IP network.

REQUIRE ETHERNET/IP MASTER/CLIENT

Because the Marquee is setup as an Ethernet/IP server/slave device, a client/master device is required to exchange data and message numbers to the Marquee. The Client/master must support Ethernet/IP Class 1 I/O Messaging in order to control the Marquee. If the controlling device supports Ethernet/IP I/O control then the controller can control the Marquee. Typical examples of this are the Rockwell Automation ControlLogix and CompaqLogix series of controllers. There may be other controllers available but only these two controllers, with Ethernet/IP Communications, have been verified at this time.

ETHERNET/IP CONNECTION

The IP-0XXX-T Marquees are equipped with 2 Ethernet ports. A plant Ethernet port used for configuration and monitoring over the plant network and an Ethernet/IP port for connecting to an Ethernet/IP I/O controller.

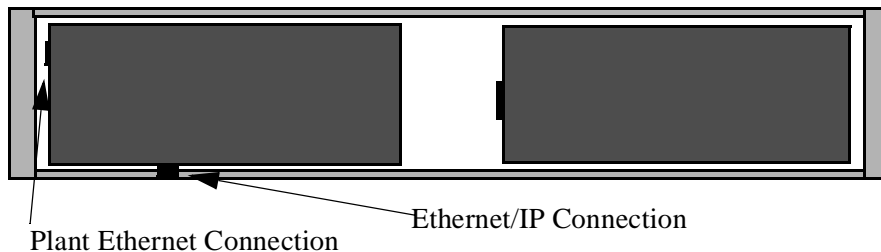

Ethernet/IP Implementation

The connector used for the Ethernet/IP network is a M12 D-Coded Ethernet/IP connector. This connector passes the 4 wire Ethernet/IP signals to the internal Ethernet/IP processor. The following table shows the pinout of this connector.

Pinouts	<i>eurofast</i>
1. White/Orange (+ tx) 2. White/Green (+rx) 3. Orange (-tx) 4. Green (-rx)	Female 

The corresponding interconnecting cordsets may be purchased separately from Exor or your preferred sensor/network cordset provider.

Ethernet/IP Specification

The following table lists the specifications on the IP-0XXX-T Ethernet/IP implementation.

Table 3—Ethernet/IP Specification

Specification	Data	Description
Vendor ID	119	Exor Vendor ID code
Product Type	24	HMI
Product Code	1	Data Visor Marquee
Revision	1	
Product Name	Data Visor Marquee	
Input Assembly	Instance 101	4 ints of inputs
Output Assembly	Instance 102	32 ints of output
Configuration Assembly	Instance 128	0 bytes

INPUT INSTANCE DATA MAP

The 4 integers of the input instance are for future use and have no operation at this time.

OUTPUT INSTANCE DATA MAP

The following table describes the output instance of the Marquee and gives a description on each attribute of the instance.

Table 4—Output Instance Data Map

Offset	Operation	Description
0	Enable	Enable Marquee Communications must always be a value of 1
1	Message Register 1	Message number to display or if the marquee is in BIT MESSAGE CALL-UP then controls messages 1-16.
2	Message Register 2	Message number to display or if the marquee is in BIT MESSAGE CALL-UP then controls messages 17-32.
3	Message Register 3	Message number to display or if the marquee is in BIT MESSAGE CALL-UP then controls messages 33-48.
4	Message Register 4	Message number to display or if the marquee is in BIT MESSAGE CALL-UP then controls messages 49-64.
5	Variable Data Register 0	For embedding data into message as @0
6	Variable Data Register 1	For embedding data into message as @1
7	Variable Data Register 2	For embedding data into message as @2
8	Variable Data Register 3	For embedding data into message as @3
9	Variable Data Register 4	For embedding data into message as @4
10	Variable Data Register 5	For embedding data into message as @5
11	Variable Data Register 6	For embedding data into message as @6
12	Variable Data Register 7	For embedding data into message as @7
13	Variable Data Register 8	For embedding data into message as @8
15	Variable Data Register 9	For embedding data into message as @9
16-31	Future Use	No operation at this time

PLC Program Configuration Example

The following example uses screen shots from RSLogix programming software. This package is used to program/configure the Rockwell Automation CompaqLogix and ControlLogix family of controllers.

- STEP 1

Open the controller programming software and start a new application. The user must complete the mandatory operation such as adding the controller type and hardware including the Ethernet/IP interface card.

- STEP2

Under I/O configuration, select the Ethernet/IP interface and right click to ADD A NEW MODULE. Select GENERIC ETHERNET MODULE.

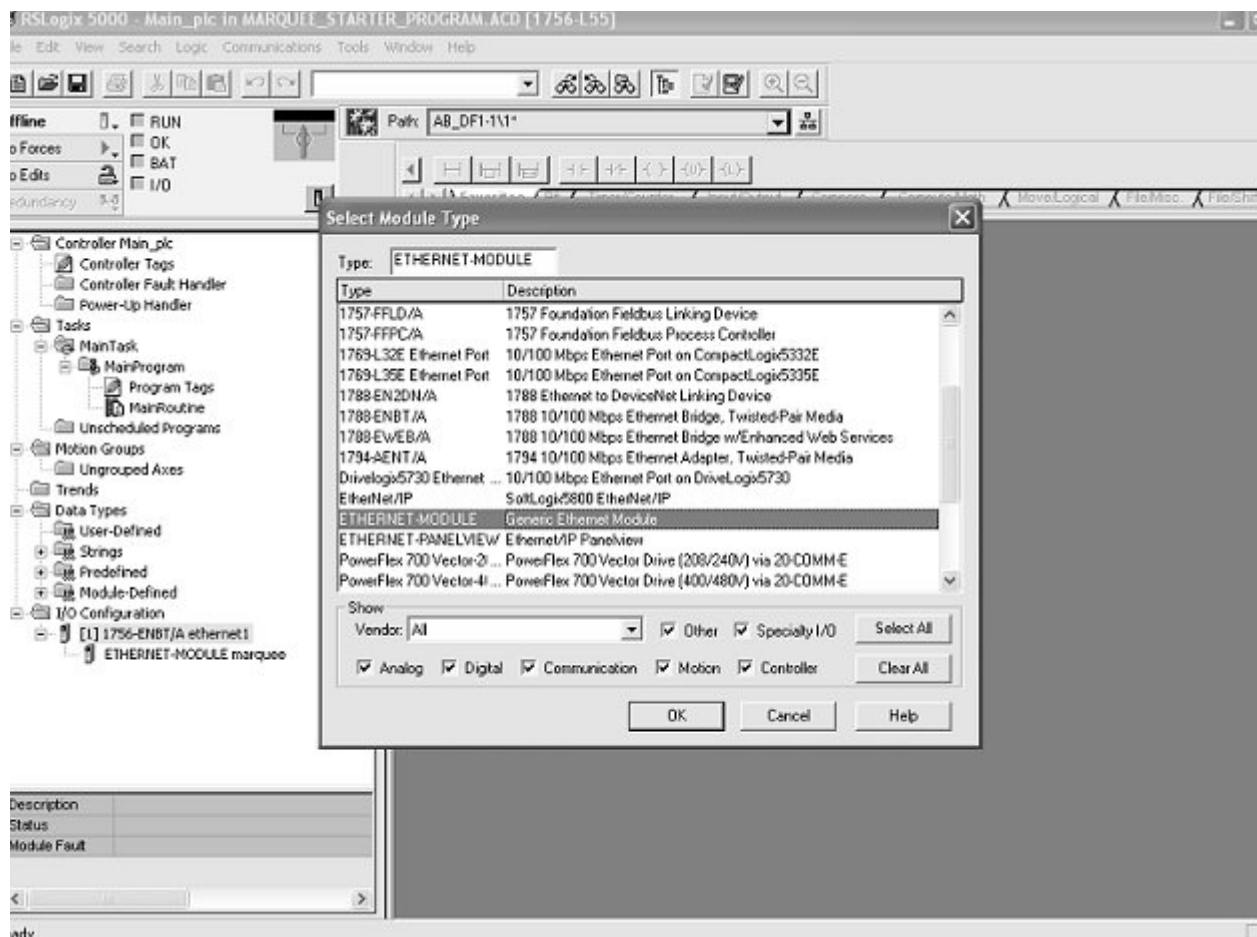

- STEP 3

Configure the Marquee parameters. Note the NAME enter will be used by the controller software as the default TAG names.

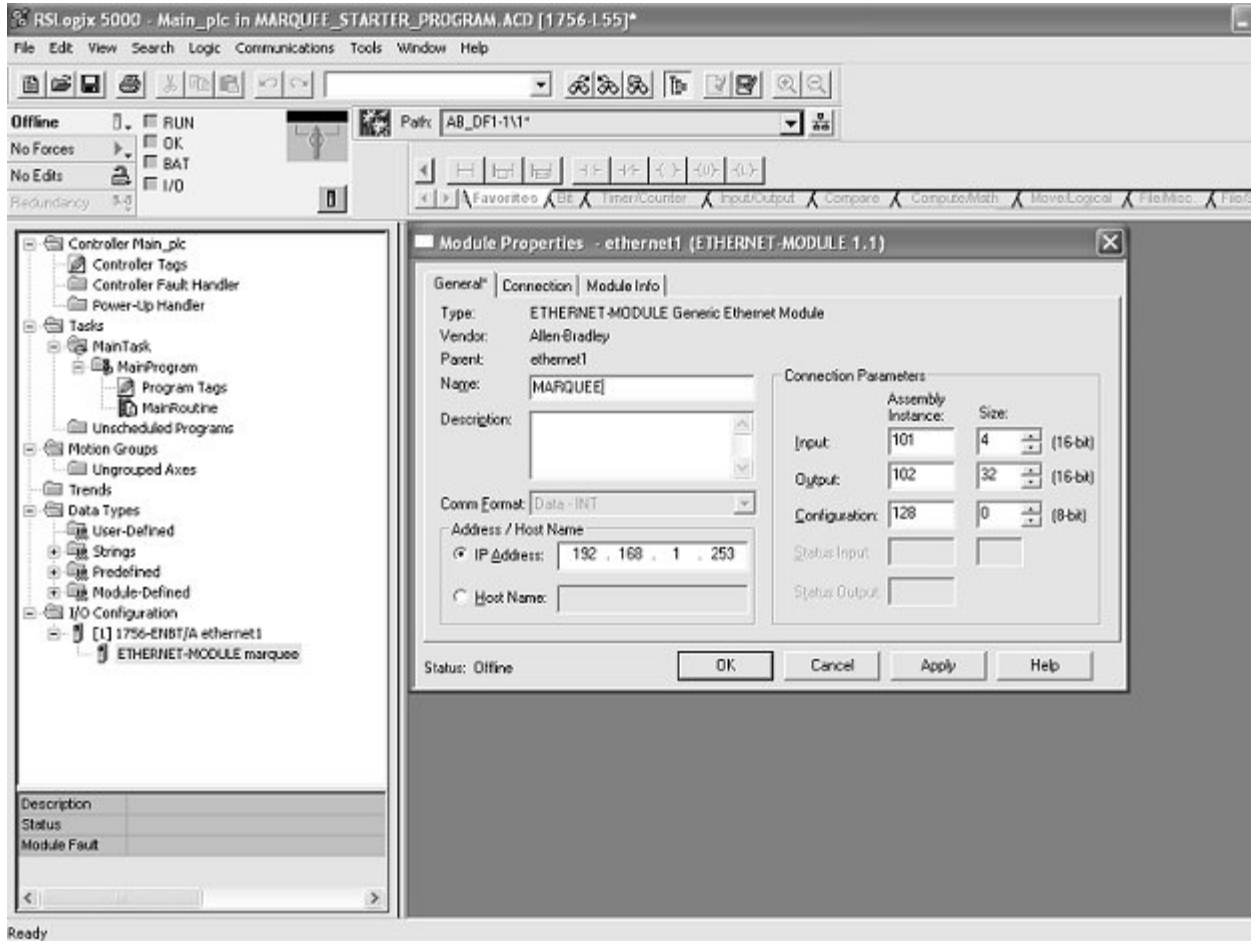

MODULE PROPERTIES

The following are the properties that must be set in the software in order for the Marquee to operate correctly.

Table 5—Module Properties

Field	Value
Name	Any valid name. Will be used as TAG name
Comm Format	Data-Int
IP Address	IP address of Marquee
Input	Instance:101 size: 4
Output	Instance:102 size:32
Configuration	Instance:128 size:0

- STEP 4

Use the generated TAG names in your program.

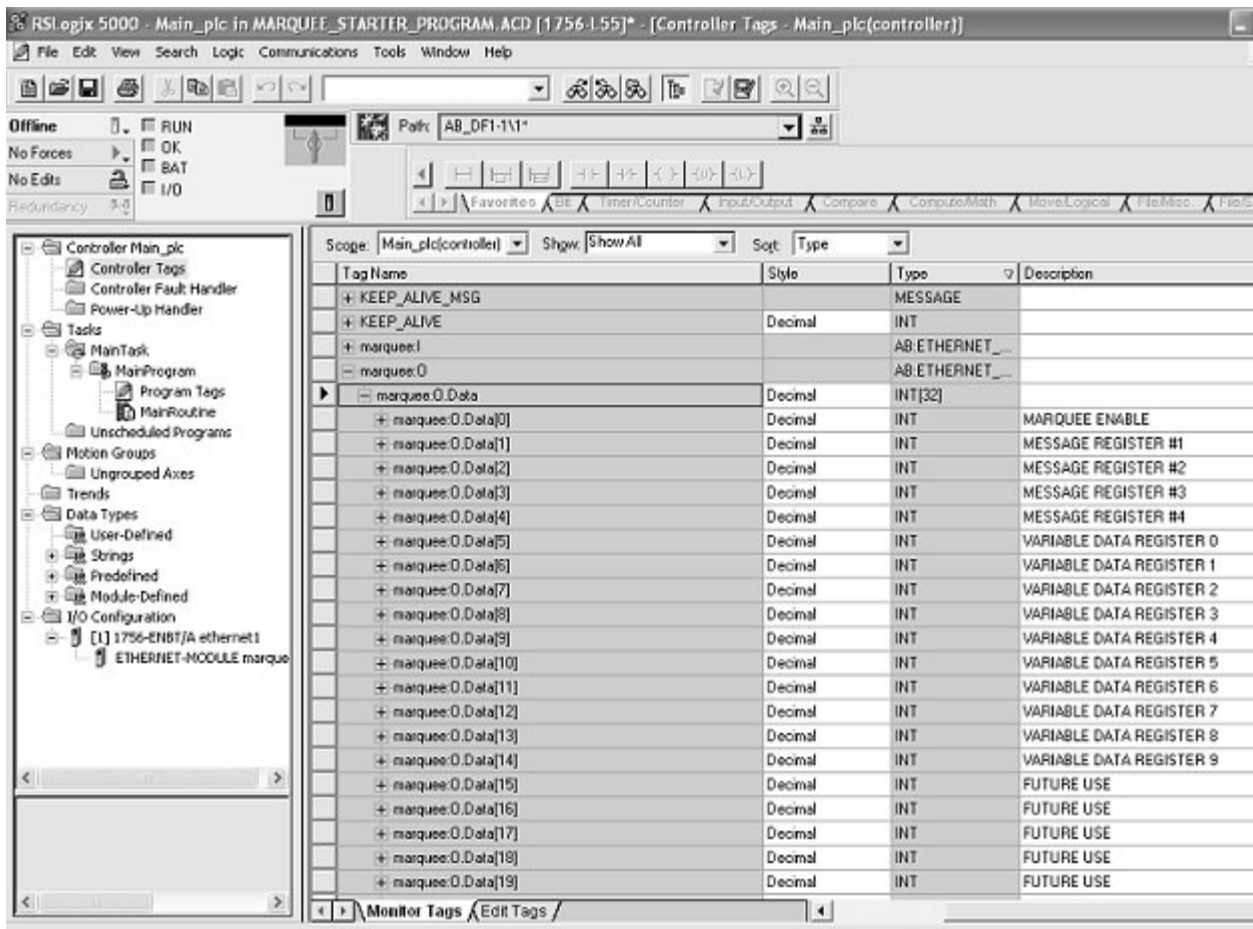

Note: The Enable Tag (offset 0) must always have a value of 1 to allow the Marquee to operate.

Message number Tags (offset 1-4) are used to tell the Marquee what message to display. Each message that is stored within the Marquee has a corresponding Message number. Example to display the first message the user moves a value of 1 into one of the 4 message number registers. If more than one message is being requested, the Marquee will automatically cycle through these messages.

Variable Data Registers (offset 5-14) are used to display data onto the Marquee. These registers can be embedded into the text of the message by the user. What ever value is placed in the register will be displayed on the Marquee as specified.

Marquee WEB Pages

This chapter discusses the WEB page configuration menus of the Marquee. The Marquee has a built in WEB server so as the user may use any WEB browser to open the configuration pages and configure the Marquee for the application at hand. This chapter is designed to give in depth information about each configuration page. The next chapter gives the user sample setups that a user can use in order to accomplish some standard tasks.

MAIN PAGE

The Main page is the initial page that is displayed when the user opens a WEB browser and types in the IP address of the Marquee. The Main Display Page displays the current message that is being displayed on the Marquee. The user may also configure data from the PLC to be displayed.

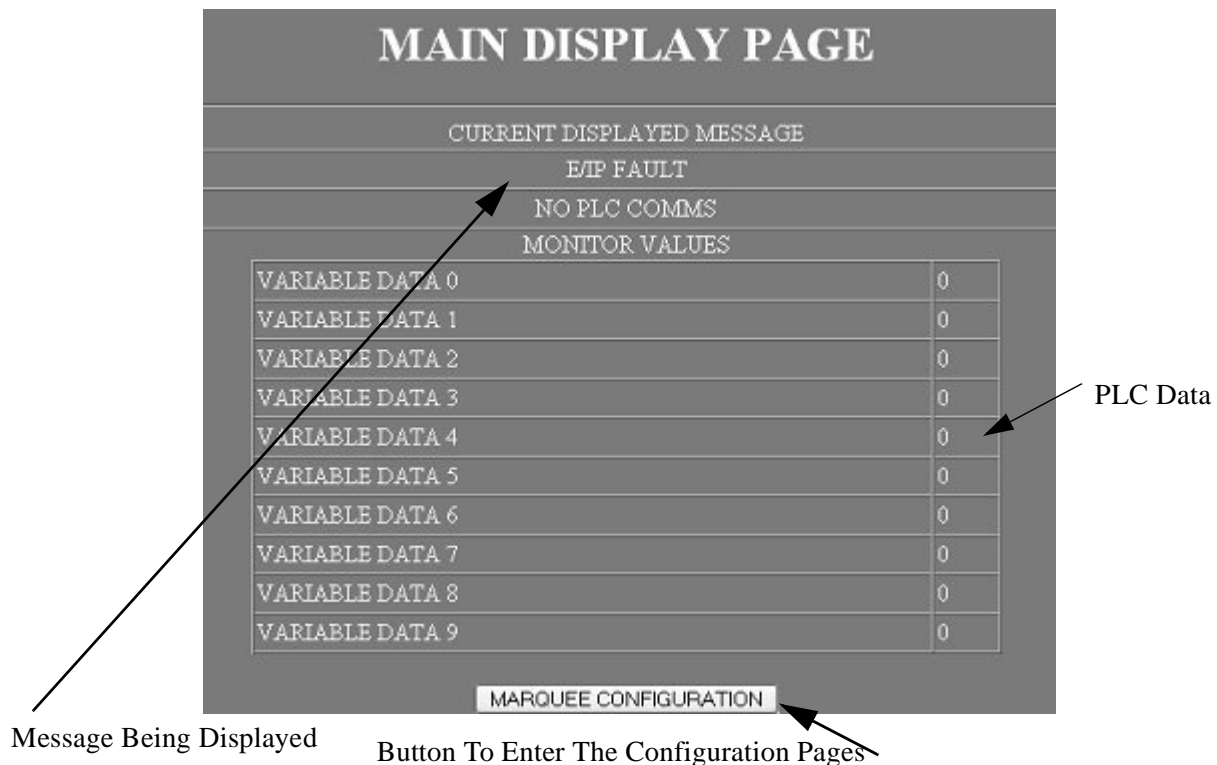

Figure 1—Main Page

Access Configuration Pages

Access to the configuration pages is password protected. This feature allows only designated users the ability of changing the Marquee configuration. To access the configuration pages click the MARQUEE CONFIGURATION button. A password entry screen will be displayed.

Note: The default user name is **admin** and the default password is **admin**. This may be changed in the NETWORK CONFIGURATION page.

WARNING—If the user name or password are changed please record the new setting and store them in a safe location for future reference.



User defined user name and password (default **admin**)

Figure 2—Password Entry Page

SETUP MENU

The setup menu allows the user to access the Marquee configuration pages. This page consists of 8 configuration page access buttons and a return button.

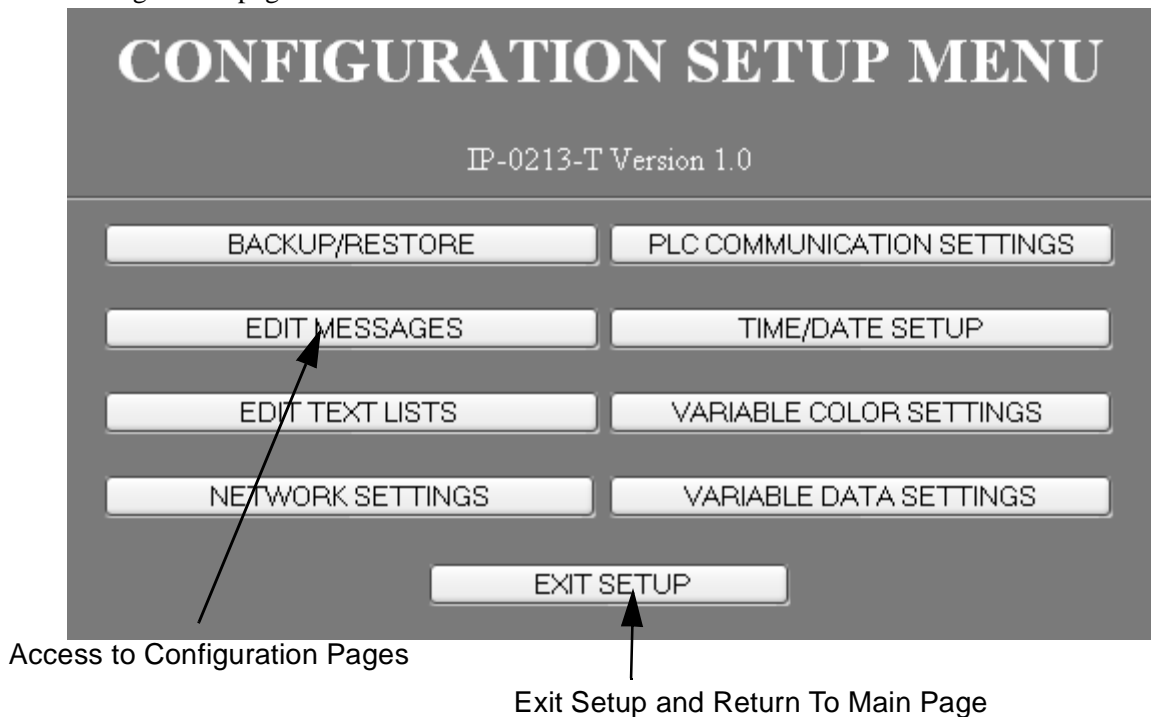

Figure 3—Setup Menu Page

Note: A common operation within all configuration pages is that the APPLY button must be clicked prior to leaving the page in order for any changes that have been made to take affect. If the user leaves the page prior to clicking on the APPLY button any changes made on that page will be discarded.

BACKUP AND RESTORE PAGE

This page allows the user to backup the Marquee configuration onto the PC or restore/load a previously stored configuration into the Marquee.

BACKUP AND RESTORE

LOAD AN EXISTING MARQUEE FILE

SAVE CURRENT MARQUEE CONFIGURATION TO A FILE

LOAD AN EXISTING MARQUEE FILE

BROWSE

This button opens the file explorer so the user may find the file to restore/load into the Marquee.

RESTORE

After a configuration file has been specified, this button initiates the transfer of the file to the Marquee.

SAVE CURRENT MARQUEE CONFIGURATION TO A FILE

This button is used to initiate the saving of the configuration of the Marquee to a file on the PC. Upon pressing this button the user selects **SAVE** and specifies the location to save the configuration file. Please note that the file name may be changed to better describe the configuration being saved.

EDIT MESSAGE

This page allows the configuration of messages that will be displayed on the Marquee. The user has the ability to configure up to 100 messages that can be displayed on the Marquee. The message that is displayed on the Marquee is determined by the value or bits that are active in the MESSAGE CALL UP registers over Ethernet/IP.

MSG #	MSG TEXT	FONT	LINE	COLOR	FLASH	MINIMUM DISPLAY TIME
1	MESSAGE #1	4"	ALL LINES	RED	<input type="checkbox"/>	2 SEC
2	MESSAGE #2	4"	ALL LINES	RED	<input type="checkbox"/>	2 SEC
3	MESSAGE #3	4"	ALL LINES	RED	<input type="checkbox"/>	2 SEC
4	MESSAGE #4	4"	ALL LINES	RED	<input type="checkbox"/>	2 SEC
5	MESSAGE #5	4"	ALL LINES	RED	<input type="checkbox"/>	2 SEC
6	MESSAGE #6	2"	LINE 1	RED	<input type="checkbox"/>	2 SEC
7	MESSAGE #7	2"	ALL LINES	RED	<input type="checkbox"/>	2 SEC
8	MESSAGE #8	2"	LINE 1	RED	<input type="checkbox"/>	2 SEC
9	MESSAGE #9	2"	LINE 1	RED	<input type="checkbox"/>	2 SEC
10	MESSAGE #10	2"	LINE 1	RED	<input type="checkbox"/>	2 SEC

APPLY CHANGES MESSAGES 11-20 MESSAGES 21-30 MESSAGES 31-40 MESSAGES 41-50
 MESSAGES 51-60 MESSAGES 61-70 MESSAGES 71-80 MESSAGES 81-90 MESSAGES 91-100
 MARQUEE SETUP MENU

Figure 4—Edit Message Page

MSG

This field indicates the message number for the corresponding fields to the right. The message number is used to associate a value to the message. This number is used within the controller to display the corresponding message on the Marquee. Message numbers range from 1-100, which in turn allows the user to program up to 100 messages that can be displayed on the Marquee.

MSG TEXT

This field allows the user to specify the text of the message. The message text is limited to 80 characters. If a message is larger than can be displayed on the Marquee, the Marquee will automatically parse the message into multiple parts and display one part at a time until the message is completely displayed. The time that any given part is displayed is based on the selection under MINIMUM DISPLAY TIME.

A group of special identifiers are available to be embedded within the text of the message to do such things as embed variable data. An identifier always starts with the @ character followed by a single character to specify the operation. The following table lists the identifiers available to the user.

Identifier	Operation
@T or @t	The time of the Marquees real time clock will be embedded in the message.
@D or @d	The date of the Marquees real time clock will be embedded in the message.
@R or @r	Characters following this will be displayed in the color red.
@G or @g	Characters following this will be displayed in the color green.
@Y or @y	Characters following this will be displayed in the color yellow.
@N or @n	Forces the text after this identifier to the next line of the display. Note that if the message is only displayed on one line then this indicates the start of the next section of the message to be displayed on that line. Not valid on 1 line units.
@0 - @9	Variable data index selected will be displayed within the message. The manner the data is displayed is based on the settings within the VARIABLE DATA SETTINGS PAGE.

Table 1—Special Identifiers

FONT

This field is used to specify the character size of the message. Two choices are available 2” or 4” character height.

Note: Not present on 1 line units.

LINE

The LINE field is used to select which line the message will be displayed. Please note selection of line number 3 and 4 are only available on the 4 line model.

Line	Operation
ALL LINES	The message will clear the display then start on the first line and wrap to consecutive lines.
LINE 1	The message will only clear line #1 and the text of the message will be displayed on line #1. All other lines of the display will be unaffected.
LINE 2	The message will only clear line #2 and the text of the message will be displayed on line #2. All other lines of the display will be unaffected.
LINE 3	The message will only clear line #3 and the text of the message will be displayed on line #3. All other lines of the display will be unaffected.
LINE 4	The message will only clear line #4 and the text of the message will be displayed on line #4. All other lines of the display will be unaffected.

Table 2—Line Selection

Note: Not present on 1 line units.

COLOR

The color field allows the user to specify the color of the message to be displayed. The color of the message can be either a fixed color or based on the color selected for a variable data register. By choosing a variable color the message can change colors based on the value or state of the register within the controller. Please note this is the default color and can be overridden by placing a color change identifier within the text of the message.

Table 3—Color Selection.

Selection	Operation
RED	Message color will be Red.
GREEN	Message Color will be Green.
YELLOW	Message color will be Yellow.
VD0-VD9	Message color will be based on the color associated with the variable data register.

FLASH

If this checkbox is checked, the message text will flash. Note that if the color selection is based on a variable this field is ignored and the message will only flash if the color section for the variable data has been selected to flash.

MINIMUM DISPLAY TIME

Display time is time between the display being updated. An example of this is if the message sent to the display is too big to display at one time then the display will display one portion of the message followed by the second portion. The time that the first portion is displayed before displaying the second portion is the display time. Also if multiple messages are being called up that use the same line, this is the time between each message being displayed.

EDIT TEXT LIST

A text list allows the user to specify a text string to display based on the value of a variable data register. This allows the user to display machine states or other text values embedded within the message. There are 10 text lists that can be configured within the Marquee. Any of the 10 variable data registers can be associated to any of these text lists. Refer to VARIABLE DATA SETTINGS page on how to associate a text list to a variable data register.

TEXT LIST CONFIGURATION

VALUE BASED TEXT LIST 0

CONDITION	TEXT
DEFAULT TEXT	DOWN
> OR = 1	STANDBY
> OR = 2	RUNNING
> OR = 0	TEXT #3
> OR = 0	TEXT #4
> OR = 0	TEXT #5
> OR = 0	TEXT #6
> OR = 0	TEXT #7
> OR = 0	TEXT #8
> OR = 0	TEXT #9

APPLY CHANGES
TEXT LIST 2
TEXT LIST 3
TEXT LIST 4
TEXT LIST 5

TEXT LIST 6
TEXT LIST 7
TEXT LIST 8
TEXT LIST 9
TEXT LIST 10

MARQUEE SETUP MENU

CONDITION

The condition column is used to specify the value at which the corresponding text will be used. Any condition value that is set to 0 will be ignored. 9 condition values can be used along with a default text. The default text is used if no other condition is true or all condition value are set to 0.

EXAMPLE: The user sets VD0 to use text list 1 for display. The user then configures text list 1 to display RUN as the default text and DOWN if the value is greater or equal to 10. The user then creates a message that includes VD0, MACHINE STATE @0. As long as the value of VD0 is less than 10 the message will be displayed as MACHINE STATE RUN. If the value of VD0 is equal to or greater than 10 the message displayed will be MACHINE STATE DOWN.

NETWORK SETTINGS

This page is used to configure the Marquee’s built-in Plant ethernet network. This ethernet connection is used to connect the Marquee to the facility or plant network. This connection is used to configure the Marquee and monitor the text and data the Marquee is receiving from the PLC connected to the Ethernet/IP ethernet network.

Note: If the Marquee is to be connected to the plant network, the IT department or network administrator of your facility should be consulted prior to assigning ethernet network parameters.

The screenshot shows a web interface titled "ETHERNET CONFIGURATION". Underneath, there is a section labeled "NETWORK SETTINGS" containing a table with the following fields and values:

IP ADDRESS	192.168.001.200
SUBNET MASK	255.255.255.000
DEFAULT GATEWAY	000.000.000.000
WEB USER ID	admin
WEB PASSWORD	admin

Below the table, there are two checkboxes, both of which are unchecked:

- BROADCAST MESSAGE ON NETWORK :
- RECIEVE NETWORK BROADCAST MESSAGES :

At the bottom of the form, there are two buttons: "APPLY CHANGES" and "MARQUEE SETUP MENU".

Figure 5—Ethernet Configuration Page

IPADDRESS

This field is used to specify the IP address of the built-in ethernet port of the Marquee. If an invalid IP address is entered by the user it will be rejected when the APPLY button is clicked.

SUBNET MASK

This field is used to specify the SubNet mask used by the built-in ethernet port of the Marquee. If an invalid SubNet mask is entered by the user it will be rejected when the APPLY button is clicked.

DEFAULT GATEWAY

This field is used to specify the Default Gateway used by the built-in ethernet port of the Marquee. If an invalid Default Gateway is entered by the user it will be rejected when the APPLY button is clicked.

WEB USER ID

This field is used to specify the user ID that is used when accessing the configuration pages of the MARQUEE.

Note: If a change is made to this field and then the APPLY button is clicked, the user will be disconnected from the Marquee. The user must then restart the browser and log back into the Marquee with the new WEB USER NAME and/or WEB PASSWORD to continue configuration.

WEB PASSWORD

This field is used to specify the password that is used when accessing the configuration pages of the MARQUEE.

Note: If a change is made to this field and then the APPLY button is clicked, the user will be disconnected from the Marquee. The user must then restart the browser and log back into the Marquee with the new WEB USER NAME and/or WEB PASSWORD to continue configuration.

BROADCAST MESSAGE ON NETWORK

This selection allows the user to specify whether or not the Marquee will broadcast the message that is received across the Ethernet Network. The purpose of this function is to reduce both the time for application development and network traffic. If this selection is checked, upon receiving a UDP message the Marquee will rebroadcast the message on the network. Any Marquee that has been configured to receive the broadcast message will then display the same message as the broadcaster.

RECIEVE NETWORK BROADCAST MESSAGES

This selection allows the user to specify that the Marquee will allow receiving of broadcast messages. If this selection is checked, upon a Marquee broadcasting a message the Marquee will display the broadcast message.

PLC COMMUNICATIONS SETTINGS

This page allows the user to configure both the Ethernet/IP port of the Marquee along with specify how the message registers will be used. This page also allows the user to specify a default message that will be displayed on the Marquee if no message is being called up by the PLC.

ETHERNET/IP NETWORK SETTINGS

NETWORK SETTINGS

ETHERNET/IP NETWORK SETTINGS

IP ADDRESS	192.168.001.253
SUBNET MASK	255.255.255.000

MESSAGE CALLUP OPTION REGISTER VALUE MESSAGE CALLUP ▾

DEFAULT MESSAGE (IF MESSAGE NUMBER = 0)

LINE #	MSG TEXT	COLOR	FLASHING	MINIMUM DISPLAY TIME
1	DEFAULT MESSAGE LINE 1	RED ▾	<input type="checkbox"/>	2 SEC ▾
2	TIME @T DATE @D	RED ▾	<input type="checkbox"/>	2 SEC ▾

APPLY CHANGES

MARQUEE SETUP MENU

ETHERNET/IP NETWORK SETTINGS

IP ADDRESS

This field is used to specify the Ethernet/IP address of the Marquee. This is the IP address used within the PLC when configuring the Marquee on the Ethernet/IP network.

SUBNET MASK

This field is used to specify the Subnet Mask for the Ethernet/IP network. The Mask specified must match the Subnet Mask defined in the PLC.

MESSAGE CALL-UP OPTION

This selection allows the user to select how the 4 message call-up registers will be used. The user has the ability to choose either:

REGISTER VALUE MESSAGE CALL-UP

Each of the 4 message call-up registers are read as a value that corresponds to the message number. In the register value is greater than 0 then the message number specified will be displayed on the Marquee.

In this manner, the user only needs to move the value of the message to display into a message register and the message will be displayed.

BIT LEVEL MESSAGE CALL-UP

This selection is used to specify that the message registers will be examined as a 64 bit array of bits. In this mode each bit of the message registers controls the display of a single message number.

Message Register 0 = Messages 1-16

Message Register 1 = Messages 17-32

Message Register 2 = Message 33-48

Message Register 3 = Messages 49-64

In this manner, the user only needs to turn on a bit within a message register and the corresponding message will be displayed.

DEFAULT MESSAGES

Default messages are the messages that are displayed on the Marquee if the message registers are a value of 0 or no bits are turned on within the message registers. Due to the fact that a message can be configured to only write to 1 line of the display, each line has it's own default message.

LINE

Indicates the line that this default message will be displayed on.

MESSAGE TEXT

The text and any special operators for the default message.

COLOR

The color of the text for the message.

FLASHING

Selection to indicate that this message will flash on and off on the Marquee.

MINIMUM DISPLAY TIME

If the message is too large to be displayed at one time, this is the time between the message being cycled through on the display.

TIME/DATE SETUP

The TIME/DATE SETUP page is used to configure the real time clock operations of the Marquee.

TIME and DATE

These field are used to set the real time clock of the Marquee. The user must supply the time in 24 hour format and the date in month/day/year format. If the user does not supply the correct format the setting will be ignored. After the user has entered the correct time and date, pressing the SET TIME/DATE button will initiate the time update to the Marquee.

TIME AND DATE DISPLAY FORMAT

This section allows the user to specify how time and date will be displayed on the Marquee.

TIME

Selection for how time will be displayed if included within a message.

Table 4—Time Display Format

SELECTION	DISPLAYED
24 HOUR HH:MM	Displays time in 24 hour format including hour and minute only

Table 4—Time Display Format

SELECTION	DISPLAYED
24 HOUR HH:MM:SS	Displays time in 24 hour format including hour, minute and seconds.
12 HOUR HH:MM AM/PM	Displays time in 12 hour format AM/PM with hour and minute only.
12 HOUR HH:MM:SS AM/PM	Displays time in 12 hour format AM/PM including hour, minute and second.

DATE

Selection for how the date will be displayed if included within a message.

Table 5—Date Display Format

SELECTION	DISPLAYED	EXAMPLE
DD MMM YYYY	Displays day of month, 3 character month abbreviation and 4 digit year.	25 Dec 2005
MMM DD YYYY	Displays 3 character month abbreviation, day of month and 4 digit year.	Dec 25 2005
DD/MM/YYYY	Displays day of month/month/4 digit year.	25/12/2005
MM/DD/YYYY	Displays month/day of month/4 digit year.	12/25/2007
YYYY.MM.DD	Displays 4 digit year.month.day of month.	2005.12.25

ALLOW NETWORK TIME SYNC.

This option allows the Marquee's real time clock to be synchronized to a master clock on the network. In order for this to operate, a marquee on the same network must be defined as a master clock. The master clock Marquee broadcasts a time sync message that any Marquee that is configured to ALLOW NETWORK TIME SYNC. received the sync message and updates it's real time clock.

USE AS MASTER CLOCK

This option is used to specify that this Marquee is the master clock on the network. In turn the Marquee will broadcast the current time and date to all other Marquees that are defined to receive the network time sync.

BROADCAST TIME EVERY

If the Marquee is defined as the master clock, this selection allows the user to specify how often to transmit the time and date onto the network.

VARIABLE COLOR SETTINGS

This configuration page is used for configuring the use of variable color changes for the Marquee. Variable color is configured based on the value of a given variable data register. Each of the ten variable data registers can be configured so as the value changes the color that the variable is displayed in. Also the text of a message can change color based on this value. Please refer to EDIT MESSAGES page for details on how to configure the message to change colors based on a variable.

VALUE	COLOR
DEFAULT COLOR	RED
> OR = 0	RED
> OR = 0	RED
> OR = 0	RED
> OR = 128	RED
> OR = 0	RED

APPLY CHANGES VD 1 VD 2 VD 3 VD 4
 VD 5 VD 6 VD 7 VD 8 VD 9

MARQUEE SETUP MENU

VALUE

This column allows the user to specify the values that will dictate a color change. The DEFAULT COLOR is used if the value of the variable data register is 0 or no setpoints have been configured.

COLOR

The color column allows the user to specify the color to use for the corresponding variable. The default color is the color of the data if the variable data has a value of 0 or if no other values are configured. Each of the other color selection rows correspond to the value column of the same row.

Example: The user wishes to have the color that VD0 is displayed in change based on the value of VD0. If the value is less than 100 the color will be green. If the value is greater than or equal to 100 the value will be red. The user sets the default color for VD0 to be green then sets the first value row to a value of 100 followed by setting the color to be red.

VARIABLE DATA SETTINGS

This page is used to configure how the values within the variable data registers will be displayed.

VARIABLE DATA CONFIGURATION

MAIN PAGE TITLE :

MAIN PAGE REFRESH RATE

VARIABLE DATA CONFIGURATION

DATA	DATA DESCRIPTION	# DIGITS	PRECISION	FORMAT	JUSTIFY	COLOR	MONITOR DISPLAY
0	LINE SPEED	5	0	LEADING SPACES	RIGHT	RED	<input checked="" type="checkbox"/>
1	VARIABLE DATA 1	5	0	TEXT LIST 1	RIGHT	RED	<input checked="" type="checkbox"/>
2	VARIABLE DATA 2	5	0	LEADING SPACES	RIGHT	RED	<input checked="" type="checkbox"/>
3	VARIABLE DATA 3	5	0	LEADING SPACES	RIGHT	RED	<input checked="" type="checkbox"/>
4	VARIABLE DATA 4	5	0	LEADING SPACES	RIGHT	RED	<input checked="" type="checkbox"/>
5	VARIABLE DATA 5	5	0	LEADING SPACES	RIGHT	RED	<input checked="" type="checkbox"/>
6	VARIABLE DATA 6	5	1	LEADING SPACES	RIGHT	RED	<input checked="" type="checkbox"/>
7	VARIABLE DATA 7	5	0	LEADING SPACES	RIGHT	RED	<input checked="" type="checkbox"/>
8	VARIABLE DATA 8	5	0	LEADING SPACES	RIGHT	RED	<input checked="" type="checkbox"/>
9	VARIABLE DATA 9	5	0	LEADING SPACES	RIGHT	RED	<input checked="" type="checkbox"/>

MAIN PAGE TITLE

This field allows the user to specify the text for the title on the MAIN PAGE of the Marquee.

MAIN PAGE REFRESH RATE

This selection allows the user to specify how often the MAIN PAGE will be automatically refreshed on the WEB browser.

VARIABLE DATA CONFIGURATION

This section of the page is used to configure how each variable data registers value will be used and/or displayed.

DATA

This column contains the index of each of the corresponding variable data registers. The row data to the right is the configuration for the given variable data register.

DATA DESCRIPTION

This field allows the user to type in the text that will be displayed on the MAIN PAGE for corresponding variable data register. Please note that the user must also select MONITOR DISPLAY in order for the text and value to be displayed on the MAIN PAGE.

DIGITS

This selection allows the user to specify the number of digits to display for the variable. This is useful when creating a message with embedded variable data. The # DIGITS specified will be used by the Marquee to determine the number of characters positions to set aside for variable data within the message.

PRECISION

This selection allows the user to specify if any of the digits should be placed behind a decimal point.

Example: Value of variable data 1234

Table 6—Precision

Precision Selected	Data Displayed
0	1234
1	123.4
2	12.34
3	1.234
4	0.1234
5	.01234

FORMAT

The format selection is used to determine justification, display type or if the value relates to a text entry within a text list.

Table 7—Variable Data Formats

Format	Description
Leading Spaces	The value of the variable data is displayed with a length specified under # DIGITS with and leading 0's being replaced with spaces.
Leading Zeros	The value of the variable data is displayed with a length specified under # DIGITS with and leading 0's being displayed.

Table 7—Variable Data Formats

Format	Description
Time ##:##	Value of variable data register is displayed with 2 digits followed by a : then the second 2 digits.
Time #:##:##	Value of variable data register is displayed with 1st digit the a : followed by the next 2 digits followed by a : then the last 2 digits.
TEXT LIST 1-10	The variable data value is used to index within a text list were the data displayed is a text string and not the value of the data.

COLOR

The color selection is used to specify the display color of the variable data. The display color can be a fixed color or can be configured to be a variable color based on the VARIABLE COLOR configuration.

MONITOR DISPLAY

This selection is used to indicate the user wishes to have the ability of monitor the value of the variable data on the MAIN PAGE. If selected an entry on the MAIN PAGE will display the DATA DESCRIPTION along with the value of the variable data.

—Chapter 5—

Mounting Instructions

This chapter will discuss the mounting possibilities available. Mounting hardware is included with each Marquee.

Mounting Hardware Included



Mount Attachment
Nut 5/16 Qty 4



Slide-In Mount Attachment
Bolt 5/16 (custom) Qty 4



Mount Interconnect
Nut 6mm Qty 4



Mount Interconnect
Bolt 6mm Qty 4

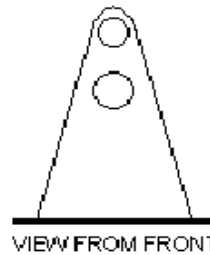

VIEW FROM FRONT

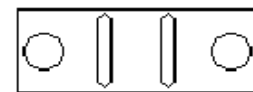

VIEW FROM BOTTOM

Hanger/Stand Mounting Bracket Qty 2

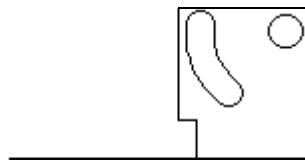

View from Front



View From Bottom

Swivel Mount Bracket

Installing Mount Attachment Bolts

Prior to mounting the Marquee the mount attachment bolts must be installed.

WARNING—In order to install the mount attachment bolts the end cap on the left (when looking at front of Marquee) must be removed.

WARNING—DO NOT REMOVE THE END CAP ON THE RIGHT HAND SIDE!

1. Remove 4 screws holding left END CAP. (A)
2. Remove END CAP.(B)
3. Slide 2 to 4 mount bolts into groove. (C)
4. Replace END CAP.
5. Place 4 END CAP screws.

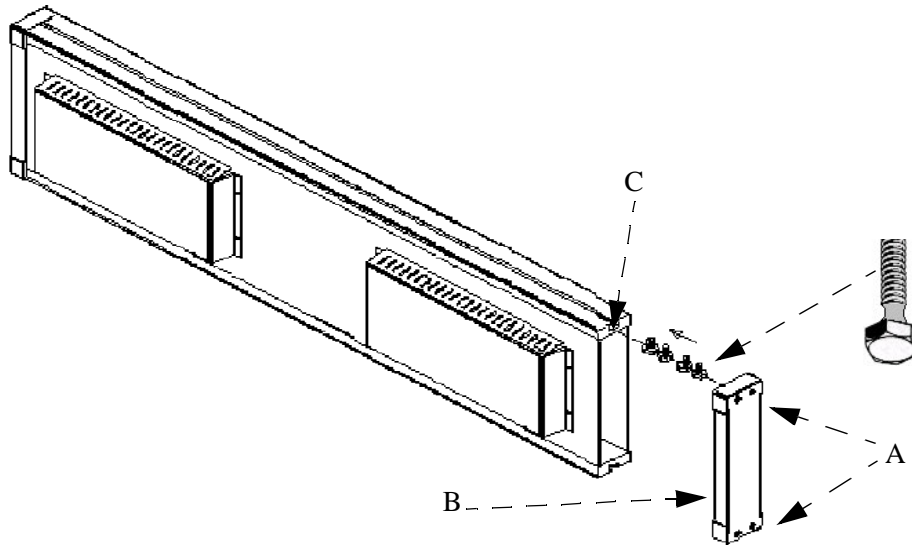

Figure 1—Installing Mount Bolts

Note: The number of bolts will be determined by desired mounting method.

Note: Bolts may be installed in top slot or bottom depending on desired mounting method.

Mounting Method Examples

This section illustrates a few of the methods of mounting the Marquee. By no means are these the only ways to mount the Marquee but are examples of how some customers have mounted the Marquee.

Chain Mount

Marquee mounting components needed:

- 4 mount attachment bolts
- 4 mount attachment nuts
- 2 hanger mounts

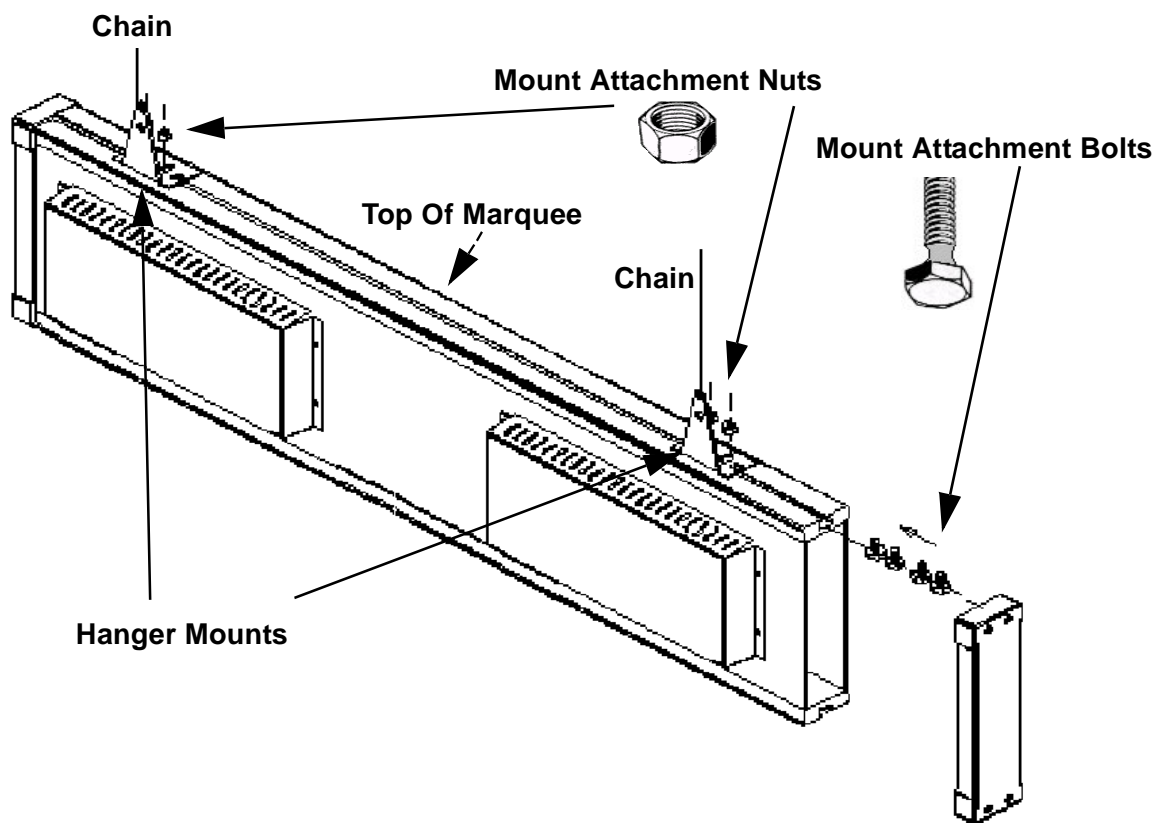

Figure 2—Chain Mount Example

Wall Mount With Swivel

Marquee mounting components needed:

- 4 mount attachment bolts
- 4 mount attachment nuts
- 2 hanger mounts
- 2 swivel mounts
- 4 mount interconnect bolts
- 4 mount interconnect nuts

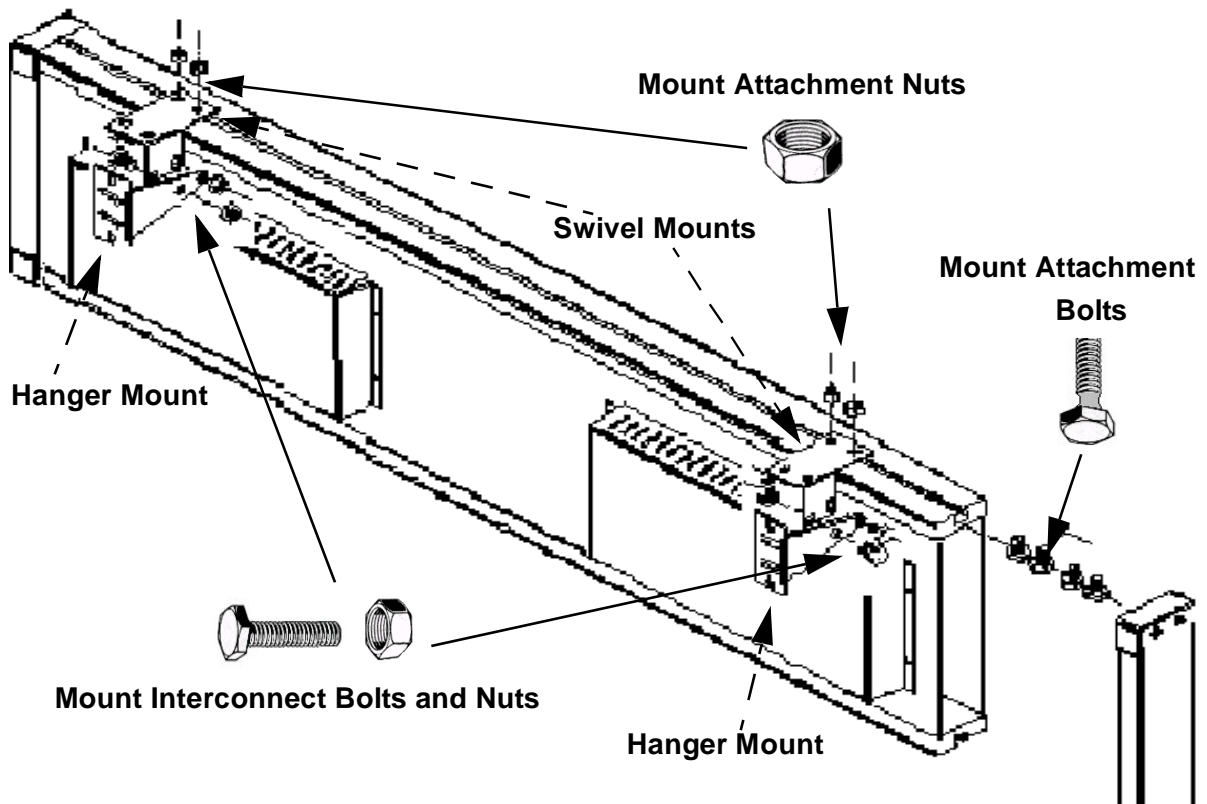

Figure 3—Wall Mount

Bottom Mount (8020 Front Mount)

Marquee mounting components needed:

- 4 mount attachment bolts
- 4 mount attachment nuts
- 2 hanger mounts

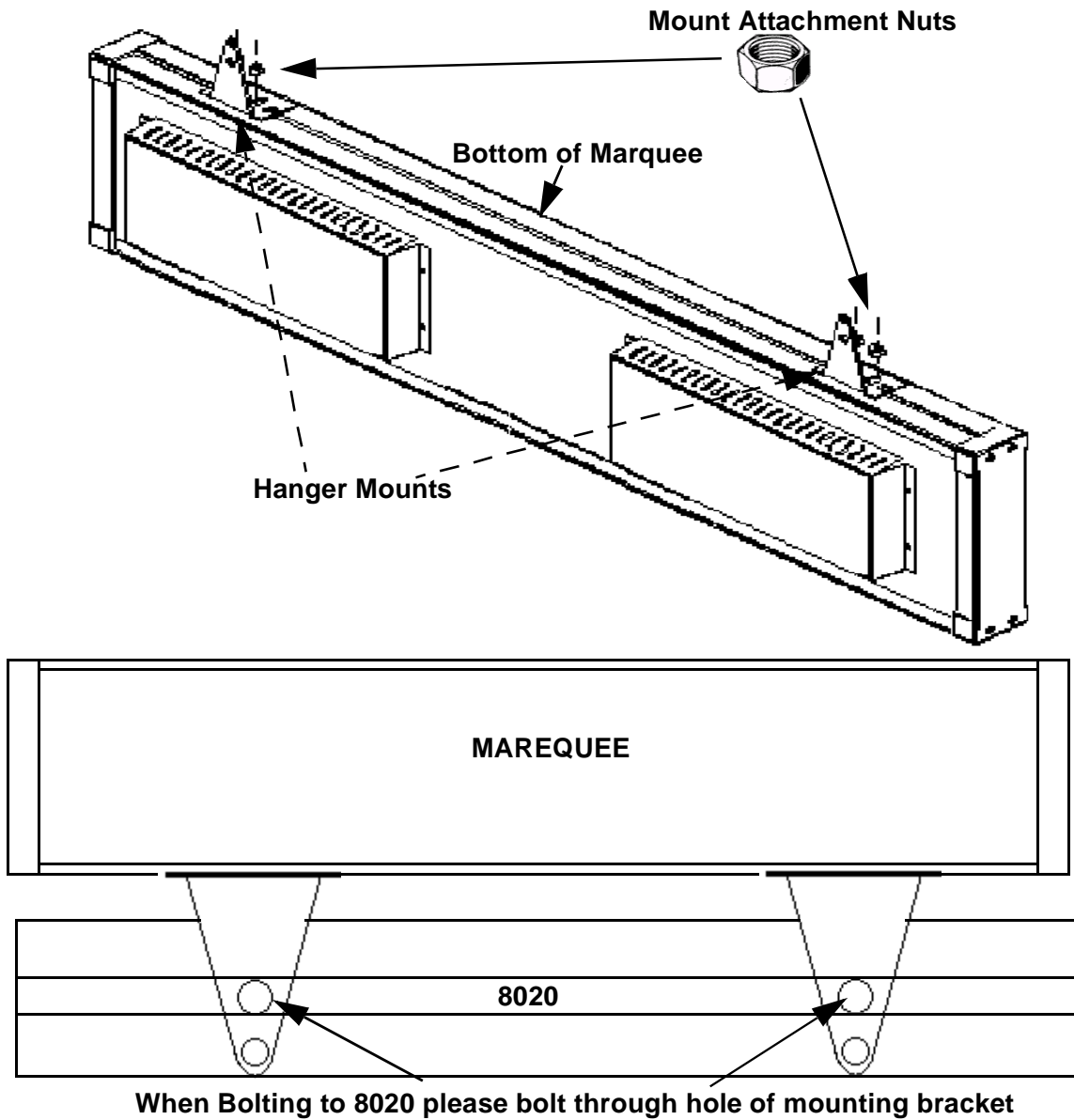

Figure 4—Bottom Mount

Bottom Mount (8020 top mount)

Marquee mounting components needed:

- 4 mount attachment bolts
- 4 mount attachment nuts
- 2 Swivel Mounts

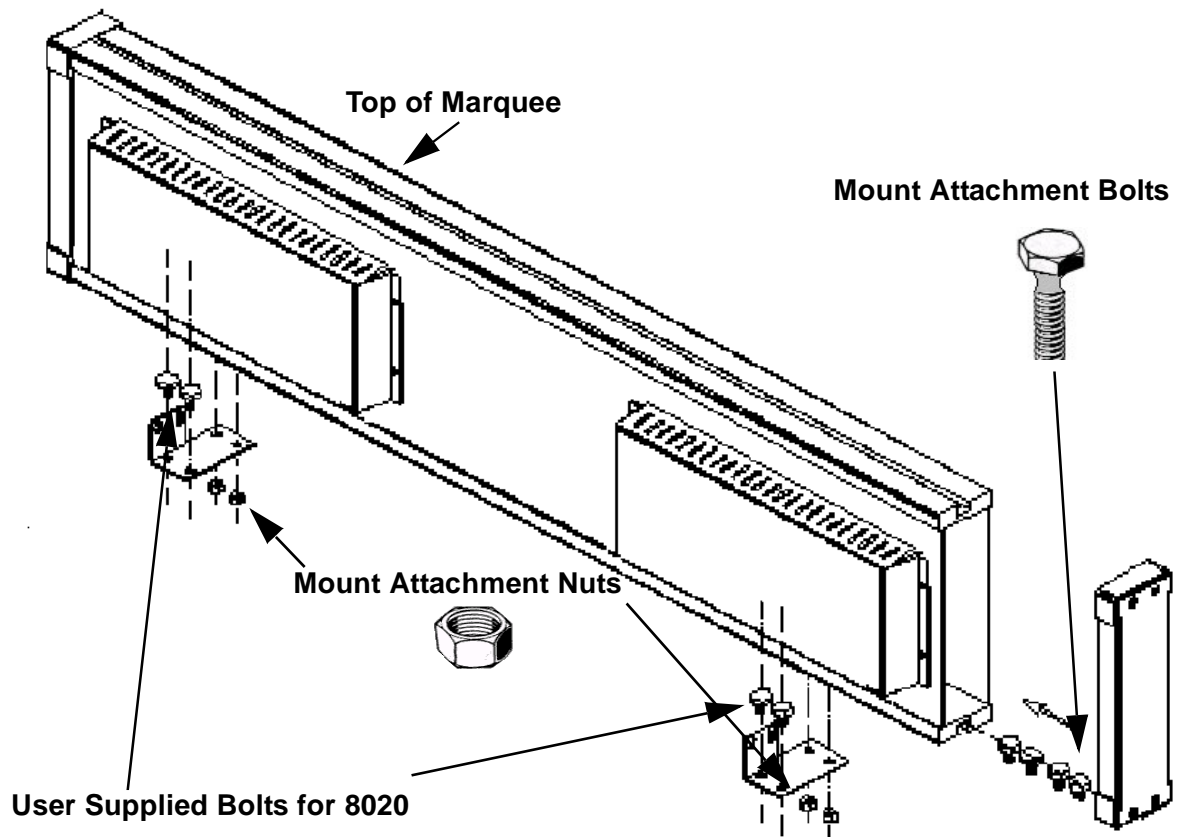

Figure 5—Bottom Mount

—Chapter 6—

Specifications

Table 1—Specifications All Models

LED PITCH	LED COLORS	LED Life	Viewing Angle	Environment
5mm	RED, GREEN & AMBER	100,000 Hours	160 Deg.	Temp. 0-55 C Humidity 15-95%

Table 2—Model Specific

Model	Dimensions	Weight	Voltage	Current (max)
IP-0113-T	26"x4.5"x1.75"	2.8 #	24 VDC	2.0 Amps
IP-0213-T	25.5"x6.25"x3.75"	10.8 #	120 VAC	0.8 Amps
IP-0220-T	39.75"x6.25"x3.75"	17.9 #	120 VAC	1.0 Amps
IP-0420-T	39.75"x11"x3.75"	26.2 #	120 VAC	2.0 Amps

Specifications